



**Free Quality
School
Education**

Ministry of
Basic and Senior
Secondary
Education

Pupils' Handbook for
Senior Secondary
Mathematics

SSS
|||

Term
|

STRICTLY NOT FOR SALE

Foreword

These Lesson Plans and the accompanying Pupils' Handbooks are essential educational resources for the promotion of quality education in senior secondary schools in Sierra Leone. As Minister of Basic and Senior Secondary Education, I am pleased with the professional competencies demonstrated by the writers of these educational materials in English Language and Mathematics.

The Lesson Plans give teachers the support they need to cover each element of the national curriculum, as well as prepare pupils for the West African Examinations Council's (WAEC) examinations. The practice activities in the Pupils' Handbooks are designed to support self-study by pupils, and to give them additional opportunities to learn independently. In total, we have produced 516 lesson plans and 516 practice activities – one for each lesson, in each term, in each year, for each class. The production of these materials in a matter of months is a remarkable achievement.

These plans have been written by experienced Sierra Leoneans together with international educators. They have been reviewed by officials of my Ministry to ensure that they meet the specific needs of the Sierra Leonean population. They provide step-by-step guidance for each learning outcome, using a range of recognized techniques to deliver the best teaching.

I call on all teachers and heads of schools across the country to make the best use of these materials. We are supporting our teachers through a detailed training programme designed specifically for these new lesson plans. It is really important that the Lesson Plans and Pupils' Handbooks are used, together with any other materials they may have.

This is just the start of educational transformation in Sierra Leone as pronounced by His Excellency, the President of the Republic of Sierra Leone, Brigadier Rtd Julius Maada Bio. I am committed to continue to strive for the changes that will make our country stronger and better.

I do thank our partners for their continued support. Finally, I also thank the teachers of our country for their hard work in securing our future.

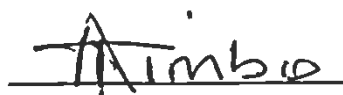

Mr. Alpha Osman Timbo

Minister of Basic and Senior Secondary Education

The policy of the Ministry of Basic and Senior Secondary Education, Sierra Leone, on textbooks stipulates that every printed book should have a lifespan of three years.

To achieve thus, DO NOT WRITE IN THE BOOKS.

Table of Contents









Lesson 1: Algebraic Processes	3
Lesson 2: Algebraic Processes	7
Lesson 3: Geometry	11
Lesson 4: Statistics	15
Lesson 5: Review of Perimeter of Regular Shapes	18
Lesson 6: Review of Area of Regular Shapes	21
Lesson 7: Area of Similar Shapes	25
Lesson 8: Area of Compound Shapes	29
Lesson 9: Review of Circles	33
Lesson 10: Length of an Arc	36
Lesson 11: Perimeter of a Sector	39
Lesson 12: Perimeter of a Segment	43
Lesson 13: Area of a Circle	47
Lesson 14: Area of a Sector	50
Lesson 15: Area of a Segment	53
Lesson 16: Area and Perimeter of Composite Shapes	56
Lesson 17: Circle Theorem 1	59
Lesson 18: Applications of Circle Theorem 1	62
Lesson 19: Circle Theorem 2	64
Lesson 20: Applications of Circle Theorem 2	67
Lesson 21: Circle Theorems 3 and 4	69
Lesson 22: Applications of Circle Theorems 3 and 4	72
Lesson 23: Circle Theorem 5	74
Lesson 24: Applications of Circle Theorem 5	77
Lesson 25: Circle Theorems 6 and 7	80

Lesson 26: Applications of Circle Theorems 6 and 7	83
Lesson 27: Circle Theorem 8 – the Alternate Segment Theorem	86
Lesson 28: Apply the Alternate Segment Theorem	90
Lesson 29: Solving Problems on Circles	93
Lesson 30: Surface Area of a Cube	96
Lesson 31: Volume of a Cube	99
Lesson 32: Surface Area of a Cuboid	102
Lesson 33: Volume of a Cuboid	105
Lesson 34: Nets of Prisms	108
Lesson 35: Surface Area of a Triangular Prism	111
Lesson 36: Volume of a Triangular Prism	114
Lesson 37: Surface Area of a Cylinder	117
Lesson 38: Volume of a Cylinder	121
Lesson 39: Surface Area of a Cone	124
Lesson 40: Volume of a Cone	128
Lesson 41: Surface Area of a Rectangular Pyramid	131
Lesson 42: Volume of a Rectangular Pyramid	135
Lesson 43: Surface Area of a Triangular Pyramid	138
Lesson 44: Volume of a triangular pyramid	142
Lesson 45: Surface Area of a Sphere	144
Lesson 46: Volume of a Sphere	148
Lesson 47: Surface Area of Composite Solids	151
Lesson 48: Volume of Composite Solids	155
Answer Key: Term 1	155
Appendix I: Protractor	158

Introduction

to the Pupils' Handbook

These practice activities are aligned to the Lesson Plans, and are based on the National Curriculum and the West Africa Examination Council syllabus guidelines. They meet the requirements established by the Ministry of Basic and Senior Secondary Education.

-  1 The practice activities will not take the whole term, so use any extra time to revise material or re-do activities where you made mistakes.
-  2 Use other textbooks or resources to help you learn better and practise what you have learned in the lessons.
-  3 Read the questions carefully before answering them. After completing the practice activities, check your answers using the answer key at the end of the book.
-  4 Make sure you understand the learning outcomes for the practice activities and check to see that you have achieved them. Each lesson plan shows these using the symbol to the right.
-  5 Organise yourself so that you have enough time to complete all of the practice activities. If there is time, quickly revise what you learned in the lesson before starting the practice activities. If it is taking you too long to complete the activities, you may need more practice on that particular topic.
-  6 Seek help from your teacher or your peers if you are having trouble completing the practice activities independently.
-  7 Make sure you write the answers in your exercise book in a clear and systematic way so that your teacher can check your work and you can refer back to it when you prepare for examinations.
-  8 Congratulate yourself when you get questions right! Do not worry if you do not get the right answer – ask for help and continue practising!



Learning Outcomes

KEY TAKEAWAYS FROM SIERRA LEONE'S PERFORMANCE IN WEST AFRICAN SENIOR SCHOOL CERTIFICATE EXAMINATION – GENERAL MATHEMATICS¹

This section, seeks to outline key takeaways from assessing Sierra Leonean pupils' responses on the West African Senior School Certificate Examination. The common errors pupils make are highlighted below with the intention of giving teachers an insight into areas to focus on, to improve pupil performance on the examination. Suggestions are provided for addressing these issues.

Common errors

1. Errors in applying principles of BODMAS
2. Mistakes in simplifying fractions
3. Errors in application of Maths learned in class to real-life situations, and vis-a-versa.
4. Errors in solving geometric constructions.
5. Mistakes in solving problems on circle theorems.
6. Proofs are often left out from solutions, derivations are often missing from quadratic equations.

Suggested solutions

1. Practice answering questions to the detail requested
2. Practice re-reading questions to make sure all the components are answered.
3. If possible, procure as many geometry sets to practice geometry construction.
4. Check that depth and level of the lesson taught is appropriate for the grade level.

¹ This information is derived from an evaluation of WAEC Examiner Reports, as well as input from WAEC examiners and Sierra Leonean teachers.

Lesson Title: Algebraic Processes	Theme: Review
Practice Activity: PHM3-L001	Class: SSS 3



Learning Outcome

By the end of the lesson, you will be able to solve simultaneous linear equations using elimination, substitution or graphing.

Overview

A linear equation is an equation where there are one or more variables. The highest power of the variables in a linear equation is one. Examples of linear equations are: $7x + 4y = 10$ and $y = 3x + 5$.

The solution for 2 linear equations with 2 unknown variables are the values of the variables that satisfy both equations at the same time, i.e. simultaneously. The solution tells us where the two straight lines intersect and is called the **point of intersection**.

Three methods are used to solve simultaneous linear equations – elimination, substitution and graphical methods.

Elimination

- Label the equations (1) and (2)
- Eliminate one of the variables, say x , by making its co-efficients the same in both equations.
- Simplify and solve for x .
- Substitute x back into either original equation and solve for y

Substitution

- Use the simpler of the two given equations to express one of the variables in terms of the other.
- Substitute into the second equation.
- Simplify and solve for x .
- Use the solution to substitute back into the first equation to find the value of the other unknown variable.

Graph

- Draw a graph of the two equations on the same axes.
- Where the lines cross over each other gives the **point of intersection** of the 2 lines.
- Read the point of intersection, (x, y) , from the graph.

Whatever method is used, check the solution by substituting the values for x and y in **both** equations.

Solved Examples

1. Solve the simultaneous linear equations $2x + y = 5, 3x - 2y = 4$.

Use either the elimination, substitution or graphical methods as required. Check the solution obtained.

Solution:

Elimination

$$\begin{array}{rcll}
 2x + y & = & 5 & (1) \\
 3x - 2y & = & 4 & (2) \\
 4x + 2y & = & 10 & (3) \quad \text{Multiply equation (1) by 2 to get equation (3)} \\
 3x - 2y & = & 4 & (4) \quad \text{Multiply equation (2) by 1 to get equation (4)} \\
 7x + 0 & = & 14 & \text{Add equations (3) to equation (4)} \\
 x & = & 2 & \text{Solve for } x \\
 2x + y & = & 5 & (1) \quad \text{Re-write equation (1)} \\
 2(2) + y & = & 5 & \text{Substitute } x = 2 \text{ in equation (1)} \\
 4 + y & = & 5 & \\
 y & = & 5 - 4 & \text{Transpose 4} \\
 y & = & 1 & \text{Solve for } y
 \end{array}$$

The solution is therefore $x = 2, y = 1$

Substitution

$$\begin{array}{rcll}
 2x + y & = & 5 & (1) \\
 3x - 2y & = & 4 & (2) \\
 y & = & 5 - 2x & (3) \quad \text{Make } y \text{ the subject of equation (1)} \\
 3x - 2(5 - 2x) & = & 4 & \\
 3x - 10 + 4x & = & 4 & \text{Transpose } -10 \\
 7x & = & 14 & \\
 x & = & 2 & \\
 y & = & 5 - 2x & (3) \quad \text{Re-write equation (3)} \\
 & = & 5 - 2(2) & \text{Substitute } x = 2 \text{ in equation (3)} \\
 & = & 5 - 4 & \\
 y & = & 1 & \text{Solve for } y
 \end{array}$$

The solution is therefore $x = 2, y = 1$

Graphing

$2x + y = 5$			
x	0	2	4
y	5	1	-3

$3x - 2y = 4$			
x	0	2	4
y	-2	1	4

The point of intersection gives the solution:

$$x = 2, y = 1.$$

Check

$2x + y = 5$ (1)	$3x - 2y = 4$ (2)
$2(2) + 1 = 5$	$3(2) - 2(1) = 4$
$4 + 1 = 5$	$6 + 2 = 4$
$5 = 5$	$4 = 4$
LHS = RHS	LHS = RHS

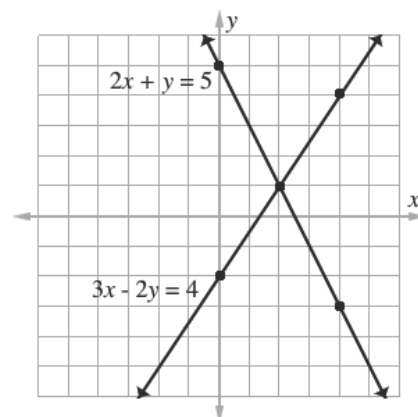

2. Solve the pair of equations simultaneously using the method of substitution.

$$\frac{2}{3}x - \frac{3}{4}y = 0 \text{ and } \frac{1}{3}x + \frac{1}{2}y = 7$$

Solution:

Elimination

$\frac{2}{3}x - \frac{3}{4}y = 0$ (1)	
$\frac{1}{3}x + \frac{1}{2}y = 7$ (2)	
$8x - 9y = 0$ (3)	Multiply equation (1) by 12 to get equation (3)
$2x + 3y = 42$ (4)	Multiply equation (2) by 6 to get equation (4)
$24x - 27y = 0$ (5)	Multiply equation (3) by 3 to get equation (5)
$18x + 27y = 378$ (6)	Multiply equation (4) by 9 to get equation (6)
$42x + 0 = 378$	Add equation (5) to equation (6)
$42x = 378$	
$42x \quad 378$	
$42 \quad 378$	
$x = 9$	Solve for x
$8x - 9y = 0$ (3)	Rewrite equation (3)
$8(9) - 9y = 0$	Substitute $x = 9$ in equation (3)
$72 - 9y = 0$	
$-9y = -72$	
$-9y = -72$	
$-9 \quad -72$	
$y = 8$	Solve for y

The solution is therefore $x = 9, y = 8$.

3. Solve the pair of equations simultaneously using the method of substitution.

$$\frac{2}{3}x - \frac{3}{4}y = 0 \text{ and } \frac{1}{3}x + \frac{1}{2}y = 7$$

**Solution:
Substitution**

$$\frac{2}{3}x - \frac{3}{4}y = 0 \quad (1)$$

$$\frac{1}{3}x + \frac{1}{2}y = 7 \quad (2)$$

$$8x - 9y = 0 \quad (3) \text{ Multiply equation (1) by 12 to get equation (3)}$$

$$2x + 3y = 42 \quad (4) \text{ Multiply equation (2) by 6 to get equation (4)}$$

$$x = \frac{9}{8}y \quad (5) \text{ Make } x \text{ the subject of equation(3)}$$

$$2\left(\frac{9}{8}y\right) + 3y = 42 \quad \text{Substitute the value } x \text{ in (5) in (4)}$$

$$\frac{9y}{4} + \frac{3y}{1} = 42$$

$$\frac{21y}{4} = 42$$

$$21y \times 1 = 42 \times 4 \quad \text{Cross multiplying}$$

$$21y = 168 \quad \text{Solve for } y$$

$$\frac{21y}{21} = \frac{168}{21}$$

$$y = 8$$

$$x = \frac{9}{8}y \quad (5) \text{ Rewrite equation (5)}$$

$$x = \frac{9}{8} \times 8 \quad \text{Substitute } y = 8 \text{ in equation (5)}$$

$$x = 9$$

The solution is therefore $x = 9, y = 8$.

Practice

Solve the following pairs of equations simultaneously using the Elimination, Substitution and Graphical methods:

1. $x + 2y = 13$

$$2x - 3y = 5$$

2. $5x - 19 = 2y$

$$3y + 18 = 4x$$

3. $4x + 3y = 1$

$$6x + 5y = -1$$

4. $\frac{1}{2}x + \frac{1}{3}y = 4$

$$\frac{1}{4}x - \frac{1}{3}y = \frac{1}{6}$$

5. $x - \frac{y}{2} = 1$

$$\frac{x}{2} + \frac{y}{3} = 2\frac{5}{6}$$

6. $x + \frac{y}{2} = \frac{1}{2}$

$$\frac{x}{2} - \frac{y}{6} = 1\frac{1}{2}$$

Lesson Title: Algebraic Processes	Theme: SSS 2 Review
Practice Activity: PHM3-L002	Class: SSS 3
 Learning Outcome By the end of the lesson, you will be able to find the equation of a line given two points and graph it on the Cartesian plane.	

Overview

In a linear equation written in the form $y = mx + c$, m is the gradient of the line, and c is the y -intercept. It is useful to write lines in this form before graphing them.

To find the equation of a line:

- For any 2 points given by (x_1, y_1) , (x_2, y_2) , the equation of the straight line through the 2 points is given by $y - y_1 = m(x - x_1)$ where $m = \frac{y_2 - y_1}{x_2 - x_1}$.
- Assign variables (x_1, x_2, y_1, y_2) to the co-ordinates of the given points.
- Find m , using the assigned variables and equation $m = \frac{y_2 - y_1}{x_2 - x_1}$.
- Substitute the co-ordinates of either of the given points into the formula $y - y_1 = m(x - x_1)$ to find the equation of the straight line.
- Check your answer by substituting the co-ordinates of the other point in the equation obtained.

To graph a straight line using the equation $y = mx + c$:

- Find the y -intercept on the Cartesian plane.
- Use the gradient to find another point on the line. Recall that $m = \frac{\text{rise}}{\text{run}}$. For “rise” we move up or down (in the y -direction), and for “run” we move left or right (in the x -direction).
- Connect the two points, graphing the line.

Solved Examples

1. Find the equation of the line through the points with co-ordinates $(2,5)$ and $(3,7)$. Draw the graph of the straight line.

Solution:

$$m = \frac{y_2 - y_1}{x_2 - x_1}$$

$$x_1 = 2; y_1 = 5; x_2 = 3; y_2 = 7$$

$$m = \frac{7-5}{3-2}$$

Assign variables to the co-ordinates of the points $(2,5)$ and $(3,7)$.

Substitute into the equation

$$= \frac{2}{1}$$

$$m = 2$$

Simplify

$$y - y_1 = m(x - x_1)$$

Equation of a straight line

$$y - 5 = 2(x - 2)$$

Substitute co-ordinates of the point (2,5)

$$y - 5 = 2x - 4$$

$$y = 2x - 4 + 5$$

Transpose -5

$$y = 2x + 1$$

Equation of the line

Check:

$$7 = 2(3) + 1$$

Substitute co-ordinates of the point (3,7)

$$7 = 6 + 1$$

$$7 = 7$$

$$\text{LHS} = \text{RHS}$$

Therefore $y = 2x + 1$ is the line through the points (2,5) and (3,7).

The graph of the equation can be drawn using scales from -2 to 4 on the x -axis and from -3 to 9 on the y -axis.

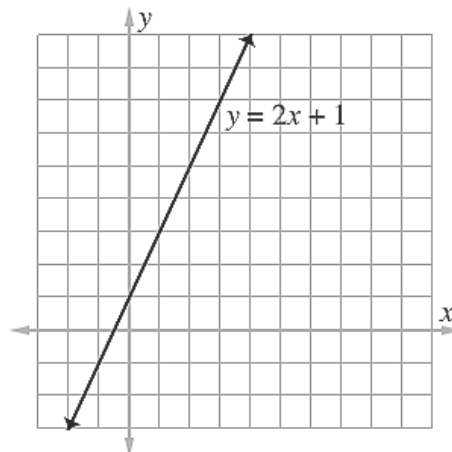

2. Find the equation of the line through the points with co-ordinates (-1, -5) and (5, 4). Draw the graph of the straight line.

Solution:

$$m = \frac{y_2 - y_1}{x_2 - x_1}$$

$$x_1 = -1; y_1 = -5; x_2 = 5; y_2 = 4$$

Assign variables to the co-ordinates of points (-1, -5) and (5, 4)

$$m = \frac{4 - (-5)}{5 - (-1)}$$

Substitute into the equation

$$= \frac{4 + 5}{5 + 1} = \frac{9}{6} = \frac{3}{2}$$

Simplify

$$m = \frac{3}{2}$$

$$y - y_1 = m(x - x_1) \quad \text{Equation of a straight line}$$

$$y - (-5) = \frac{3}{2}(x - (-1)) \quad \text{Substitute co-ordinates of the point } (-1, -5)$$

$$y + 5 = \frac{3}{2}(x + 1)$$

$$y = \frac{3}{2}x + \frac{3}{2} - 5 \quad \text{Transpose 5}$$

$$= \frac{3}{2}x - \frac{7}{2} \quad \text{Simplify } \left(\frac{3}{2} - 5 = \frac{3-10}{2} = \frac{-7}{2} = -\frac{7}{2}\right)$$

$$y = \frac{3}{2}x - 3\frac{1}{2} \quad \text{Equation of the line}$$

Check:

$$4 = \frac{3}{2} \times 5 - 3\frac{1}{2} \quad \text{Substitute co-ordinates of point } (5,4)$$

$$4 = \frac{3 \times 5}{2} - \frac{7}{2} = 4 \quad \text{Simplify } \left(\frac{(3 \times 5) - 7}{2} = \frac{15 - 7}{2} = \frac{8}{2} = 4\right)$$

$$4 = 4$$

LHS = RHS

Therefore $y = \frac{3}{2}x - 3\frac{1}{2}$ is the line through the points $(-1, -5)$ and $(5, 4)$.

The graph of the equation can be drawn using scales from -2 to 6 on the x -axis and from -6 to 5 on the y -axis.

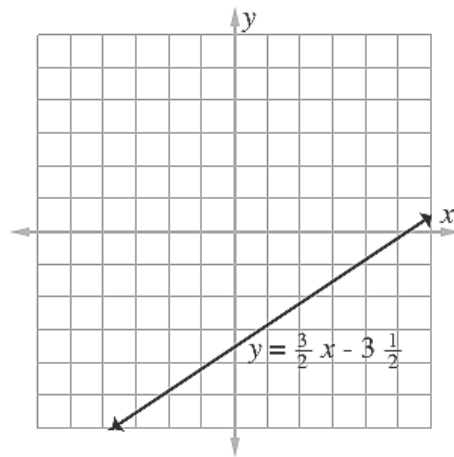

Practice

- Find the equation of the line through the points with co-ordinates. Check your solutions. Draw the graph of the straight line.
 - $(-2, 1)$ and $(3, 6)$
 - $(-2, -8)$ and $(1, 7)$
 - $(1, -5)$ and $(-7, -5)$
 - $(-1, 1)$ and $(2, 0)$
 - $(-3, 2)$ and $(5, 8)$
 - $(1, -\frac{11}{4})$ and $(\frac{2}{3}, -\frac{7}{4})$

Answer Key [include the solutions, we will move them to the end of the term/book]

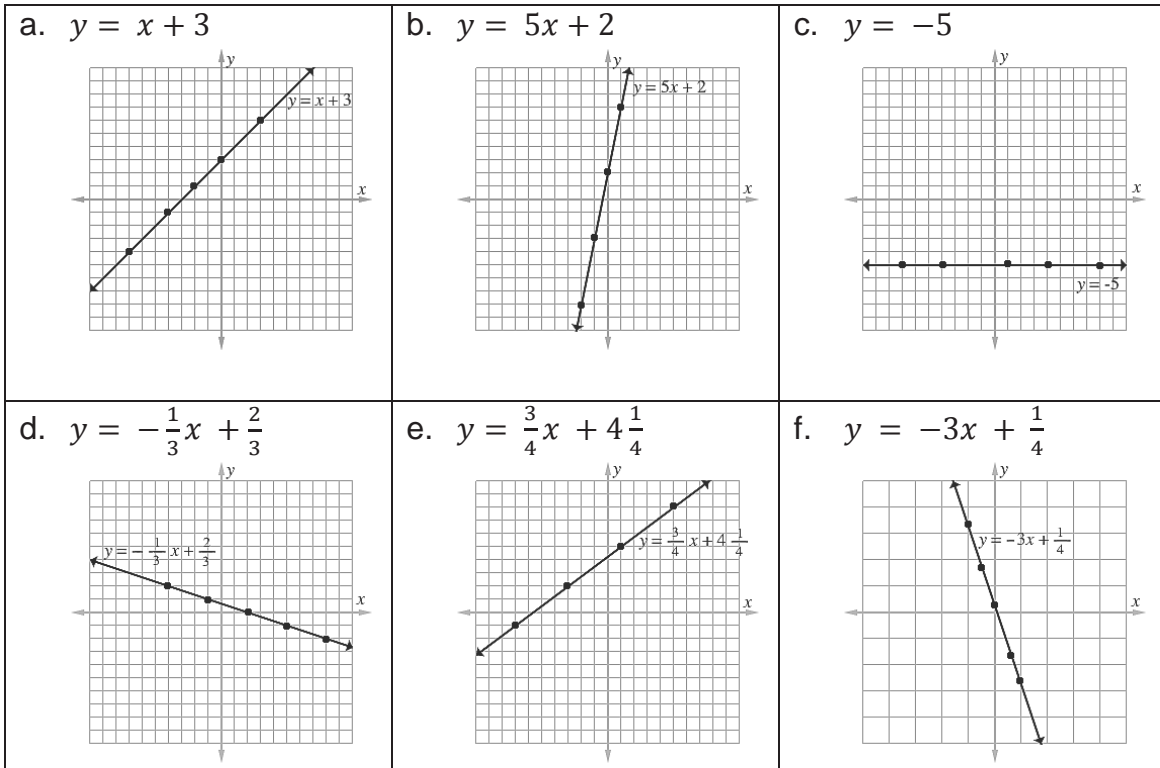

Lesson Title: Geometry	Theme: SSS 2 Review
Practice Activity: PHM3-L003	Class: SSS 3
 Learning Outcomes By the end of the lesson, you will be able to: <ol style="list-style-type: none"> 1. Calculate missing angle measures and side lengths of triangles. 2. Calculate interior and exterior angles of triangles, quadrilaterals, and other polygons. 	

Overview

Missing angles and side lengths of right-angled triangles can be solved using two methods: Pythagoras' Theorem and Trigonometry. We choose the appropriate method depending on the information given in the problem.

- Use Trigonometry if the problem is to find a missing angle and the lengths of sides are given.
- Use Trigonometry if the problem is to find a missing side and an angle and the length of one side is given.
- Use Pythagoras' Theorem if the problem is to find a missing side and the lengths of other sides are provided.

This is just a general guide. Always read the question properly before deciding which method is the most suitable. In complex diagrams, we may need to use both methods to find all the information requested.

In this lesson, we will also use standard angle theorem to calculate the interior and exterior angles of triangles and polygons.

Solved Examples

1. Find the length of AC correct to 2 decimal places in the right-angled triangle shown below.

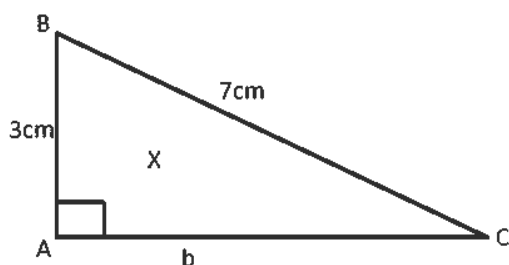

Solutions:

$$a^2 = b^2 + c^2$$

$$b^2 = a^2 - c^2$$

2. Find angle a in the right-angled triangle shown below. Give your answer to the nearest degree.

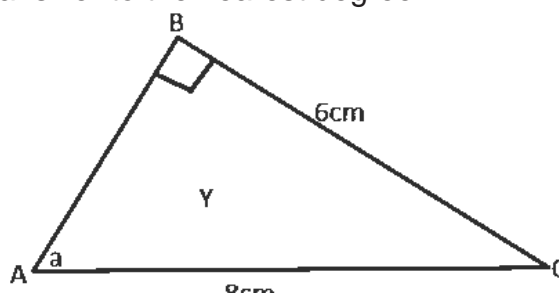

$$\begin{aligned} \sin a &= \frac{\text{opposite}}{\text{hypotenuse}} \\ &= \frac{6}{8} = 0.75 \end{aligned}$$

$$\begin{aligned}
 b^2 &= 7^2 - 3^2 \\
 &= 49 - 9 = 40 \\
 b &= \sqrt{40} \\
 b &= 6.32 \text{ cm to 2 d.p.}
 \end{aligned}$$

$$\begin{aligned}
 a &= 48.59 \\
 a &= 49^\circ \text{ to the nearest degree}
 \end{aligned}$$

3. Find |AB| in the figure given.

Solution:

$$\begin{aligned}
 \cos 48^\circ &= \frac{AB}{12} \\
 AB &= \cos 48^\circ \times 12 \\
 AB &= 0.6691 \times 12 \\
 AB &= 8.03 \text{ cm}
 \end{aligned}$$

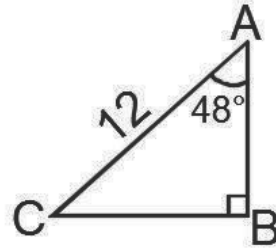

4. Find the value of α in the figure below. Give your answer to the nearest whole number.

Solution:

$$\begin{aligned}
 \sin \alpha &= \frac{17}{26} \\
 \sin \alpha &= 0.6538 \\
 \alpha &= \sin^{-1} 0.6538 \\
 \alpha &= 40.83^\circ \\
 \alpha &= 41^\circ
 \end{aligned}$$

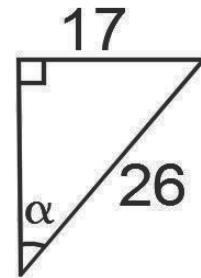

5. Find the measurements of the lettered angles in the figure at right.

Solution:

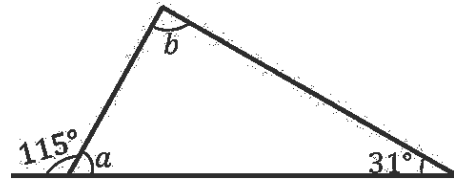

$$\begin{aligned}
 a + 115^\circ &= 180^\circ && \text{Adjacent } \angle\text{s on straight sum up to } 180^\circ \\
 a &= 180^\circ - 115^\circ \\
 a &= 65^\circ \\
 a + b + 31^\circ &= 180^\circ && \text{Interior } \angle\text{s of a } \Delta \text{ sum up to } 180^\circ \\
 65^\circ + b + 31^\circ &= 180^\circ \\
 b + 96^\circ &= 180^\circ \\
 b &= 180^\circ - 96^\circ \\
 b &= 84^\circ
 \end{aligned}$$

6. Find the measurements of the lettered angles in the figure at right.

Solution:

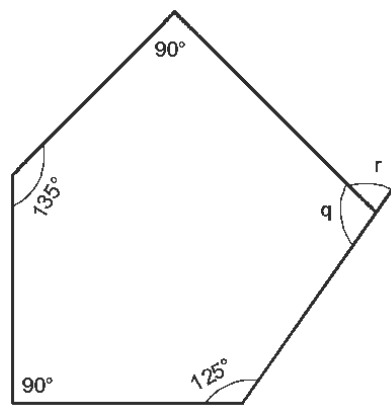

$$\begin{aligned}
 n &= 5 \quad \text{Sides of a pentagon} \\
 \text{Sum of the interior angles} &= (n - 2) \times 180 \\
 &= (5 - 2) \times 180 \\
 &= (3 \times 180) \\
 &= 540^\circ \\
 125 + 90 + 135 + 90 + q &= 540 \\
 440 + q &= 540 \\
 q &= 540 - 440 \\
 q &= 100^\circ \\
 q + r &= 180 \quad \text{Adjacent } \angle\text{s on straight sum up to } 180^\circ \\
 100 + r &= 180 \\
 r &= 180 - 100 \\
 r &= 80^\circ
 \end{aligned}$$

Practice

1. Find $\angle XZY$ in the figure below. Give your answer to the nearest whole number.

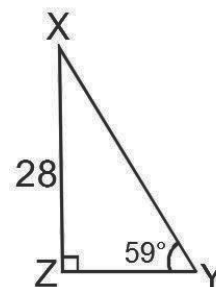

2. Find the value of β in the figure below. Give your answer to the nearest whole number.

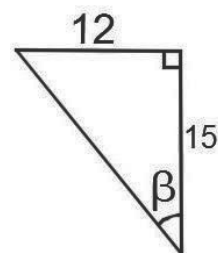

3. Find the sizes of the lettered angles in the figures below.

a.

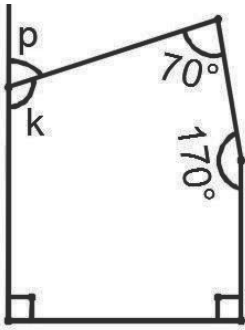

b.

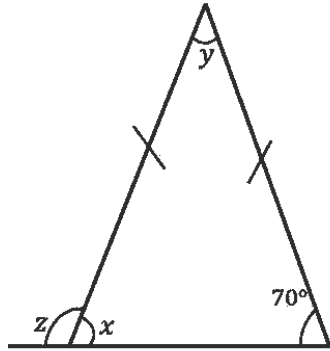

c.

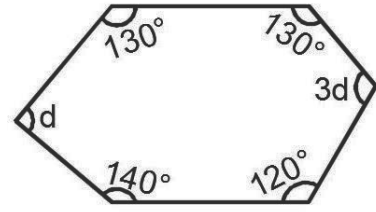

Lesson Title: Statistics	Theme: Review
Lesson Number: PHM3-L004	Class: SSS 3
 Learning Outcomes By the end of the lesson, you will be able to: <ol style="list-style-type: none"> 1. Present and interpret data. 2. Calculate measures of central tendency. 	

Overview

This lesson is a review lesson on representing and interpreting data. It will focus on representing grouped data in frequency tables and histograms. It also covers calculation of the mean, median and mode of the data.

Solved Examples

1. The heights in centimetres of 30 pupils are given below:

142 163 169 132 139 140 152 168 139 150
 161 132 162 172 146 152 150 132 157 133
 141 170 156 155 169 138 142 160 164 168

- Using class intervals of 130 – 139, 140 – 149, 150 – 159, ..., construct a frequency table.
- Draw a histogram to represent the distribution.
- Calculate the mean of the distribution.
- Estimate the median class of the distribution.
- Estimate the median height for the distribution.
- Estimate the modal class for the distribution.
- Using your histogram, estimate the modal height

Solution:

- The table below shows the results of following the steps.
- Carefully look at each step and make sure it is understood before continuing.

Step 1. i. Complete the frequency table as shown for the Height, Tally and Frequency columns.

Step 2. Add the frequencies together. Make sure $\sum f = 30$.

Height (cm)	Tally	Frequency f	Mid-point x	fx
130 – 139	### //	7	134.5	941.5
140 – 149	###	5	144.5	722.5
150 – 159	### //	7	154.5	1,081.5
160 – 169	### IIII	9	164.5	1,480.5
170 – 179	//	2	174.5	349
		$\sum f = 30$		$\sum fx = 4,575$

Step 3. ii. Draw the histogram shown right.

Step 4. Complete the frequency table for mid-point and $f \times x$.

Step 5. iii. Calculate the mean height.

$$\begin{aligned} \text{Mean} &= \frac{\sum fx}{\sum f} = \frac{4,575}{30} \\ &= 152.5 \text{ m} \end{aligned}$$

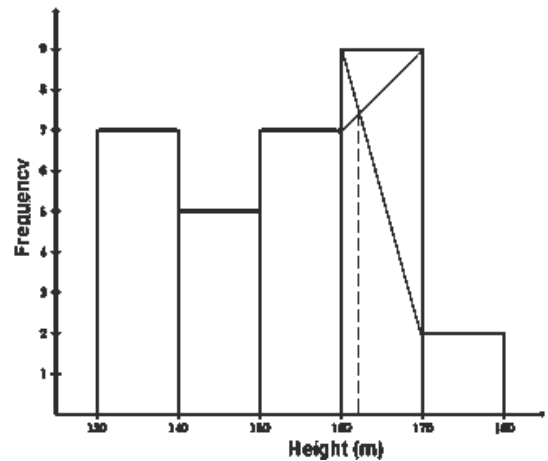

Step 6. iv. Estimate the median class of the distribution.

- For grouped data, the median is given by the data value for $\frac{\sum f}{2}$.
- $\sum f = 30$ for our distribution. So, $\frac{\sum f}{2} = 15$. The median is given by the class interval which contains the 15th pupil.
- This is the class interval of heights 150 – 159 cm. (Since there are 12 pupils in the first 2 class intervals, we have to go to the 3rd class interval before we find the 15th pupil.)

Step 7. v. Estimate the median height for the distribution.

- Since the median class was 150 – 159, the estimated median height is the mid-point of the class interval, which is 154.5 cm.

Step 8. vi. Estimate the modal class of the distribution.

- This is the class with the most number of pupils – class interval of heights of 160 – 169 cm with 9 pupils.

Step 9. vii. Estimate the modal height.

- Draw on the modal class of the histogram lines to the neighbouring classes as shown.
- Read off the histogram where the two lines intersect. This is 162 cm.

2. The distribution of marks scored in a test by a group of 30 students is shown in the table below.

Marks	10--14	15--19	20--24	25--29	30--34	35--39	40--44	45--49
No. of students	1	3	4	6	7	4	3	2

- Draw a histogram to represent the data. Using your histogram, estimate the mode of the distribution.
- Calculate: (i) the mean of the distribution.

Solution:

Marks	No. of students	Class mid-point(x)	Fx	Class boundaries
10--14	1	12	12	9.5 - 14.5
15--19	3	17	51	14.5 - 19.5
20--24	4	22	88	19.5 - 24.5
25--29	6	27	162	24.5 - 29.5
30--34	7	32	224	29.5 - 34.5
35--39	4	37	148	34.5 - 39.5
40--44	3	42	126	39.5 - 44.5
45--49	2	47	94	44.5 - 49.5
	30		905	

$$\text{Mean} = \frac{\sum fx}{\sum f} = \frac{905}{30}$$
$$= 30.17$$

$$\text{Mode} = 31.75$$

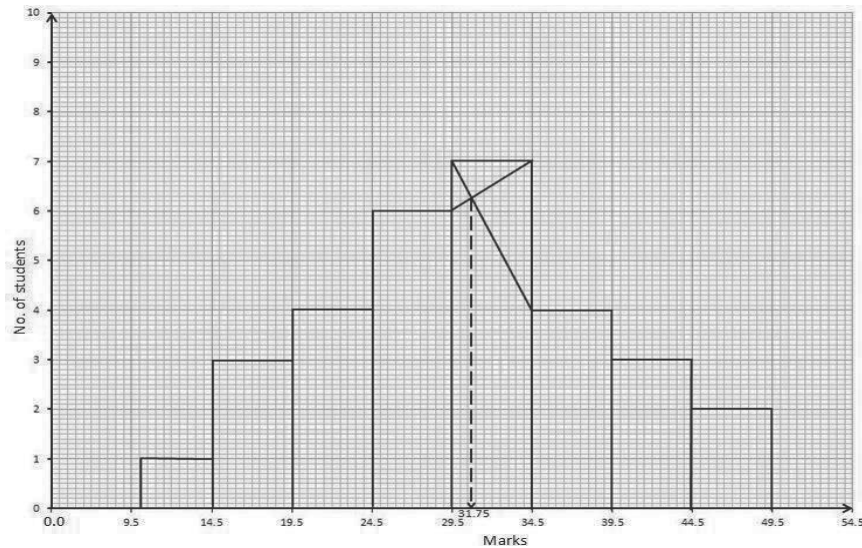

Practice

1. The marks scored by 30 students in a particular subject are as follows:

39 31 50 18 51 63
10 34 42 89 73 11
33 31 41 25 76 13
26 23 29 30 51 91
37 64 19 86 9 20

- Prepare a frequency table, using class – intervals 1--20, 21--40.
- Use the table to draw a histogram.
- Estimate the mode from the histogram
- Calculate the mean mark.

Lesson Title: Review of perimeter of shapes	Theme: Mensuration
Practice Activity: PHM3-L005	Class: SSS 3
 Learning Outcome By the end of the lesson, you will be able to determine and use the correct formula to calculate the perimeter of a specified shape.	

Overview

- This lesson reviews how to calculate the perimeter of specified regular shapes.
- The perimeter of a shape is the total length around the shape.
- The perimeter of some common shapes are given in the table below.

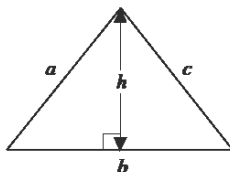
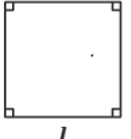
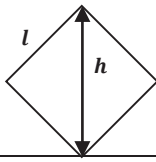
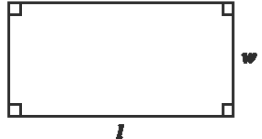
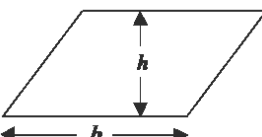
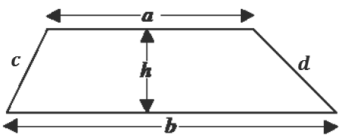
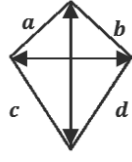
Shape	Additional information	Perimeter
Triangle		$a + b + c$
Square, Rhombus	 	$4l$
Rectangle		$2l + 2w$
Parallelogram		$2b + 2s$
Trapezium, Kite	 	$a + b + c + d$

Solved Examples

1. The length of a rectangle is 2 cm more than the width of the rectangle. The perimeter of the rectangle is 20 cm. Find the length and the width of the rectangle.

Solution:

$$P = 2l + 2w$$

$$l = w + 2$$

$$\begin{aligned}
 P &= 2(w + 2) + 2w && \text{Substitute for } l \\
 &= 2w + 4 + 2w \\
 P &= 4w + 4 \\
 20 &= 4w + 4 && \text{Substitute } P = 20 \\
 20 - 4 &= 4w && \text{Transpose 4} \\
 16 &= 4w \\
 4 &= w \\
 w &= 4 \\
 l &= w + 2 = 4 + 2 = 6
 \end{aligned}$$

The width, w , of the rectangle = 4 cm, length, l = 6 cm

2. $PQRS$ is a trapezium in which $|PS| = 9\text{cm}$, $|QR| = 15\text{cm}$, $\angle PQR = 90^\circ$ and $\angle SRQ = 30^\circ$. Calculate the perimeter of the trapezium.

$$\begin{aligned}
 \tan 30^\circ &= \frac{PQ}{6} \\
 PQ &= 6 \times \tan 30^\circ \\
 PQ &= 3.46 \text{ cm} \\
 \cos 30^\circ &= \frac{6}{SR} \\
 SR &= \frac{6}{\cos 30^\circ} \\
 SR &= 6.93 \text{ cm}
 \end{aligned}$$

$$\begin{aligned}
 \text{Perimeter} &= PS + SR + QR + PQ \\
 &= 9 \text{ cm} + 6.93 \text{ cm} + 15 \text{ cm} + 3.46 \text{ cm} \\
 &= 34.39 \text{ cm}
 \end{aligned}$$

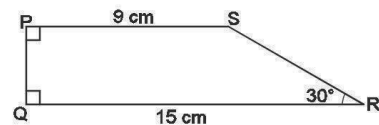
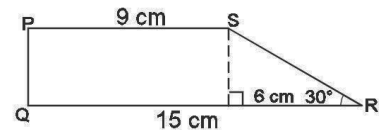

3. The sides of a rectangular floor are x m and $(x + 7)$ m.

The diagonal is $(x + 8)$ m, calculate, in metres:

a. The value of x

b. the perimeter of the floor.

$$(x + 8)^2 = (x + 7)^2 + x^2 \quad \text{Pythagoras' theorem}$$

$$\begin{aligned}
 x^2 + 16x + 64 &= x^2 + 14x + 49 + x^2 \\
 x^2 - x^2 - x^2 + 16x - 14x + 64 - 49 &= 0 \\
 -x^2 + 2x + 15 &= 0 \\
 x^2 - 2x - 15 &= 0 \\
 (x + 3)(x - 5) &= 0 \\
 x = -3, x = 5
 \end{aligned}$$

Therefore $x = 0$ as lengths cannot be negative

$$\text{Length} = x + 7 = 5 + 7 = 12 \text{ cm}$$

$$\text{Width} = 5 \text{ cm}$$

$$\begin{aligned}
 \text{Perimeter} &= 2(\text{Length} + \text{Width}) \\
 &= 2(12 \text{ cm} + 5 \text{ cm}) \\
 &= 2(17 \text{ cm}) \\
 &= 34 \text{ cm}
 \end{aligned}$$

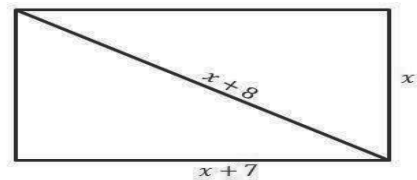

4. The diagonals AC and BD of a rhombus $ABCD$ are 16 cm and 12 cm long respectively. Calculate the perimeter of the rhombus.

$$\begin{aligned}
 AD^2 &= 8^2 + 6^2 && \text{Pythagoras' theorem} \\
 AD^2 &= 64 + 36 \\
 AD^2 &= 100 \\
 AD &= \sqrt{100} \\
 AD &= 10 \text{ cm} \\
 \text{Perimeter of rhombus} &= 4 \times AD \\
 &= 4 \times 10 \text{ cm} \\
 &= 100 \text{ cm}
 \end{aligned}$$

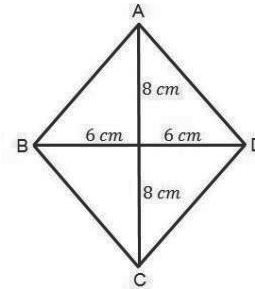

5. The diagram below shows a field whose shape is a parallelogram. Angle $\angle QST = 90^\circ$.
- a. Calculate the length QT (b) Calculate the perimeter of the field.

$$\begin{aligned}
 QT^2 &= QS^2 + TS^2 && \text{Pythagoras' theorem} \\
 QT^2 &= 40^2 + 30^2 \\
 QT^2 &= 1,600 + 900 \\
 QT^2 &= 2,500 \\
 QT &= \sqrt{2,500} \\
 QT &= 50 \text{ m} \\
 QT &= h \\
 \text{perimeter of field} &= 2(a + b) \\
 &= 2(70 + 50) \\
 &= 2(120) \\
 &= 240 \text{ m}
 \end{aligned}$$

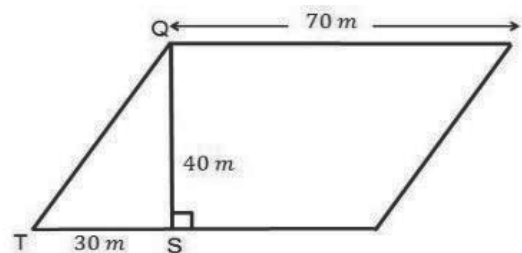

Practice

- Find the perimeter of a rectangle of length 24 cm and diagonal 25 cm.
- A rhombus, PQRS, has perimeter and a diagonal QS as 52 cm and 10 cm respectively. Calculate the length of the other diagonal.
- Find the perimeter of a rectangle of width 6 cm and diagonal 10 cm.
- A rhombus, ABCD, has perimeter and a diagonal AC as 68 cm and 30 cm respectively. Calculate the length of the other diagonal.

Lesson Title: Review of area of regular shapes	Theme: Mensuration
Practice Activity: PHM3-L006	Class: SSS 3
 Learning Outcome By the end of the lesson, you will be able to determine and use the correct formula to calculate the area of a specified shape.	

Overview

- This lesson reviews how to calculate the area of specified regular shapes.
- The area of a shape is the **amount of space** enclosed by the sides of the shape.
- The area of some common shapes are given in the table below.

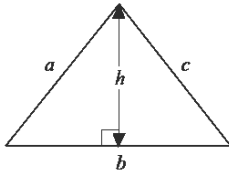
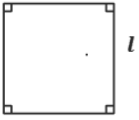
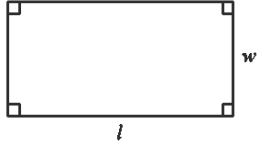
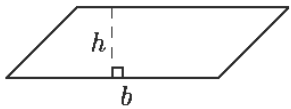
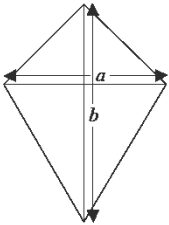
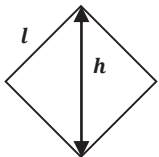
Name	Shape	Area
Triangle		$\frac{1}{2}bh$
Square		l^2
Rectangle		lw
Parallelogram		bh
Kite		$\frac{1}{2} \times$ the product of the diagonals $= \frac{1}{2}ab$
Rhombus		lh OR $\frac{1}{2} \times$ the product of the diagonals

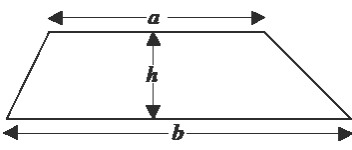
Trapezium		$\frac{1}{2}(a + b)h$
-----------	---	-----------------------

Solved Examples

1. The length of the sides of an equilateral triangle is 24 cm. Find the area of the triangle to 1 decimal place.

Solution:

- Start by drawing a sketch of the problem (shown at right).
- There are 2 right-angled triangles so use either of them to find the perpendicular height.

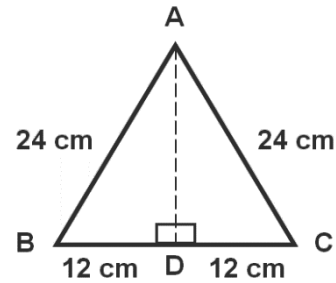

$$\begin{aligned}
 a^2 &= b^2 + c^2 \\
 24^2 &= 12^2 + |AD|^2 \\
 |AD|^2 &= 24^2 - 12^2 \\
 &= 576 - 144 = 432 \\
 |AD|^2 &= \sqrt{432} \\
 |AD| &= 20.785 \text{ cm}
 \end{aligned}$$

Use Pythagoras' Theorem to find the length of AD

Let $a = 24$, $b = 12$, $c = |AD|$

Make $|AD|^2$ the subject of the formula

Take the positive square root since lengths are always positive

$$\begin{aligned}
 A &= \frac{1}{2} \times \text{base} \times \text{height} \\
 A &= \frac{1}{2}(|BC| \times |AD|) \\
 &= \frac{1}{2}(24 \times 20.785) \\
 &= \frac{1}{2} \times 498.84 \\
 &= 249.42
 \end{aligned}$$

$$A = 249.4 \text{ cm}^2 \text{ to 1 d.p.}$$

The area of the triangle is 249.4 cm².

2. The diagonals AC and BD of a rhombus ABCD are 16 cm and 12 cm long respectively. Calculate the area of the rhombus.

Solution:

$$\begin{aligned}
 \text{Area of rhombus} &= \frac{1}{2} \times \text{product of the diagonals} \\
 &= \frac{1}{2} \times AC \times BD \\
 &= \frac{1}{2} \times 16 \text{ cm} \times 12 \text{ cm} \\
 &= 96 \text{ cm}^2
 \end{aligned}$$

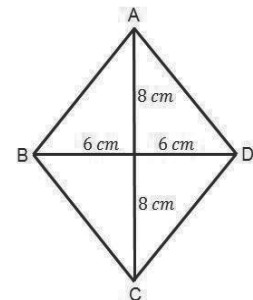

3. $PQRS$ is a trapezium in which $|PS| = 9$ cm, $|QR| = 15$ cm, $\angle PQR = 90^\circ$ and $\angle SRQ = 30^\circ$. Calculate the area of the trapezium.

Solution:

$$\begin{aligned}\tan 30^\circ &= \frac{PQ}{6} \\ PQ &= 6 \times \tan 30^\circ \\ PQ &= 3.46 \text{ cm} \\ \text{Height} &= PQ \\ \text{Area} &= \frac{1}{2}(a+b)h \\ &= \frac{1}{2}(9+15) \times 3.46 \\ &= \frac{1}{2} \times 24 \times 3.46 \\ &= 41.52 \text{ cm}^2\end{aligned}$$

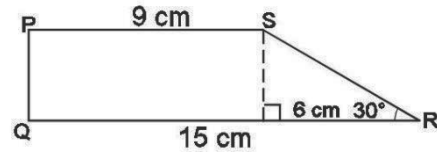

4. The diagram below shows a field whose shape is a parallelogram. $\angle ADB = 90^\circ$.
a. Calculate the length BD ; b. Calculate the area of the field.

Solution:

$$\begin{aligned}AB^2 &= BD^2 + AD^2 \\ 17^2 &= BD^2 + 8^2 \\ BD^2 &= 17^2 - 8^2 \\ BD^2 &= 225 \\ BD &= \sqrt{225} \\ BD &= 15 \text{ m} \\ BD &= h \\ \text{Area of field} &= a \times h \\ &= BF \times BD \\ &= 35 \text{ m} \times 15 \text{ m} \\ &= 525 \text{ m}^2\end{aligned}$$

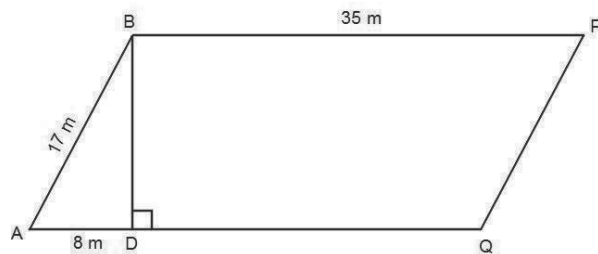

Practice

1. Find the area of the shaded region of the figure below.

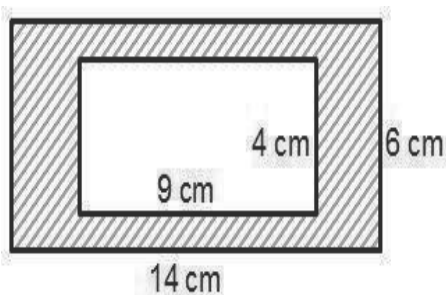

2. The area and one diagonal of a rhombus are 60 cm^2 and 12 cm respectively. Calculate the length of the other diagonal.

3. $ABCD$ is a trapezium in which $|AB| = 18$ cm, $|DC| = 12$ cm and $|BC| = 10$ cm. Calculate the area of the trapezium.

4. If the diagonals of a rhombus are 8 cm and 6 cm, find: a. The perimeter of the rhombus; b. The area of the rhombus.

Lesson Title: Area of similar shapes	Theme: Mensuration
Practice Activity: PHM3-L007	Class: SSS 3
 Learning Outcome By the end of the lesson, you will be able to calculate the area of similar shapes using the appropriate formulae.	

Overview

This lesson reviews how to calculate the lengths and area of similar shapes.

Properties of similar shapes

- They are the same shape but are almost always different sizes.
(Congruent shapes are the same shape and size).
- The corresponding lengths of the sides are in the same ratio.
- The corresponding interior angles are the same.
- The ratios of areas of similar shapes are squares of the ratio of lengths.
- For the similar triangles ABC and PQR:

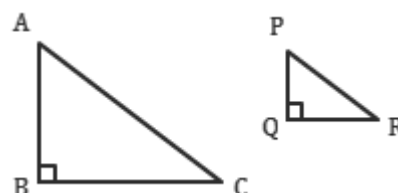

$$\frac{|AB|}{|PQ|} = \frac{|BC|}{|QR|} = \frac{|CA|}{|RP|} \quad \text{Ratio of corresponding lengths are equal}$$

$$\angle ABC = \angle PQR = 90^\circ \quad \text{Corresponding angles are equal}$$

$$\angle ACB = \angle PRQ$$

$$\angle BAC = \angle QPR$$

$$\text{area of } \Delta ABC = (\text{area of } \Delta PQR)^2$$

- The relationships for the similar triangles above are also true for other polygons as well.
- Therefore, we can find the ratio of the areas of similar shapes if we know the ratio of the lengths.
- In the same way, we can find the ratio of the lengths of similar shapes if we know the ratio of the areas.
- From this, we can find any missing lengths of the shapes.

Solved Examples

1. The diagram at right shows 2 similar rectangles A and B with widths of 12 cm and 4 cm respectively. If A has a length of 15 cm, find a. The ratio of their widths; b. The length of B ; c. The ratio of their areas.

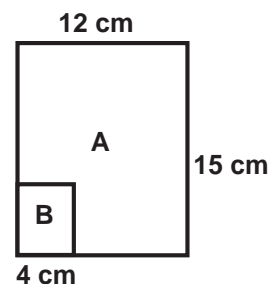

Solutions:

$$\text{a. } \frac{\text{width of } A}{\text{width of } B} = \frac{12}{4} = 3$$

$$\text{c. } \frac{\text{area of } A}{\text{area of } B} = \frac{12 \times 15}{4 \times 5}$$

$$\text{b. } \frac{\text{length of } A}{\text{length of } B} = 3$$

$$\frac{\text{area of } A}{\text{area of } B} = \frac{180}{20} = 9$$

$$\begin{aligned} \text{length of } B &= \frac{\text{height of } A}{3} \\ &= \frac{15}{3} = 5 \text{ cm} \end{aligned}$$

So, when the ratio of widths is 3, the ratio of areas is 9.

2. Find the value of t in the diagram.

Solution:

$$\begin{aligned} \frac{7 \text{ cm}}{12 \text{ cm}} &= \frac{t}{t+4} \\ 12 \times t &= 7(t+4) \\ 12t &= 7t + 28 \\ 12t - 7t &= 28 \\ 5t &= 28 \\ \frac{5t}{5} &= \frac{28}{5} \\ t &= 5.6 \text{ cm} \end{aligned}$$

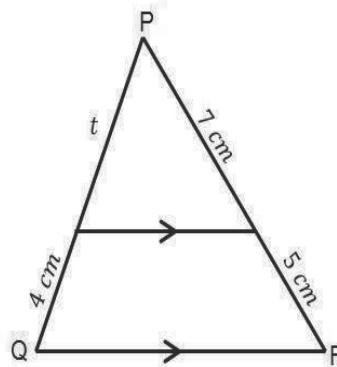

3. In the diagram below, $|AB| = 12\text{ cm}$, $|AE| = 8\text{ cm}$, $|DC| = 9\text{ cm}$ and $AB \parallel DC$. Calculate $|EC|$.

Solution:

$$\begin{aligned} \frac{EC}{AE} &= \frac{DC}{AB} \\ \frac{EC}{8\text{ cm}} &= \frac{9\text{ cm}}{12\text{ cm}} \\ EC &= \frac{8 \times 9}{12} \\ EC &= 6\text{ cm} \end{aligned}$$

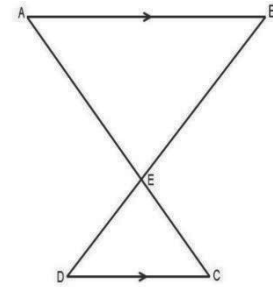

4. In the diagram, $\angle PMN = \angle PRQ$ and $\angle PNM = \angle PQR$.
If $|PM| = 3\text{ cm}$, $|MQ| = 7\text{ cm}$ and $|PN| = 5\text{ cm}$, find $|NR|$

Solution:

$$\begin{aligned} \frac{PM}{PR} &= \frac{PN}{PQ} \\ \frac{3}{PR} &= \frac{5}{10} \\ PR &= \frac{3 \times 10}{5} \\ PR &= 6\text{ cm} \\ NR &= PR - PN \\ NR &= 6\text{ cm} - 5\text{ cm} \\ NR &= 1\text{ cm} \end{aligned}$$

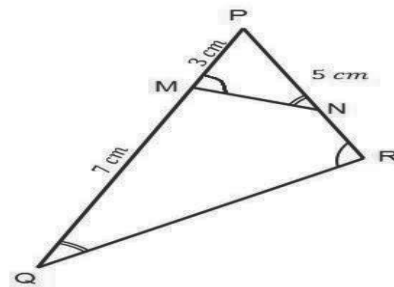

5. In the diagram, $MN \parallel PQ$, $|LM| = 3\text{ cm}$ and $|LP| = 4\text{ cm}$. If the area of $\triangle LMN$ is 18 cm^2 . Find the area of quadrilateral $MPQN$.

Solution:

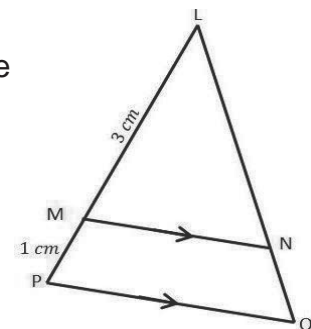

$$\begin{aligned} \frac{LM^2}{LP^2} &= \frac{LN^2}{LQ^2} &= \frac{\text{Area of } \triangle LMN}{\text{Area of } \triangle LPQ} \\ \frac{3^2}{4^2} &= \frac{LN^2}{LQ^2} &= \frac{\text{Area of } \triangle LMN}{\text{Area of } \triangle LPQ} \\ \frac{3^2}{4^2} &= \frac{\text{Area of } \triangle LMN}{\text{Area of } \triangle LPQ} &= \\ \frac{3^2}{4^2} &= \frac{18\text{ cm}^2}{\text{Area of } \triangle LPQ} \\ \text{Area of } \triangle LPQ &= \frac{18\text{ cm}^2 \times 4^2}{3^2} \\ \text{Area of } \triangle LPQ &= 32\text{ cm}^2 \\ \text{Area of quad } MPQN &= \text{Area of } \triangle LPQ - \text{Area of } \triangle LMN \\ \text{Area of quad } MPQN &= 32\text{ cm}^2 - 18\text{ cm}^2 \\ \text{Area of quad } MPQN &= 14\text{ cm}^2 \end{aligned}$$

Practice

1. In the diagram, ST and QR are parallel.
 $|PS| = 6 \text{ cm}$, $|SQ| = 8 \text{ cm}$ and $|PR| = 18\frac{2}{3} \text{ cm}$.
 Find: $|PT|$

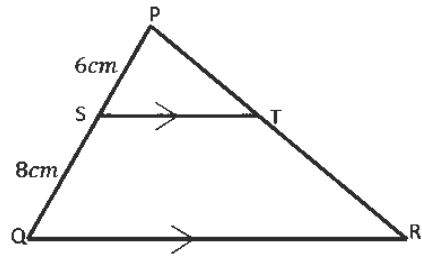

2. In the diagram, $EF \parallel QR$, $PE = 2 \text{ cm}$, $EQ = 4 \text{ cm}$ and $FR = 6 \text{ cm}$. Find x .

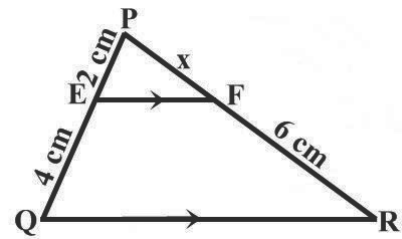

3. In the diagram, $PQ \parallel YZ$, $|XP| = 2 \text{ cm}$, $|PY| = 3 \text{ cm}$, $|PQ| = 6 \text{ cm}$ and the area of $\triangle XPQ = 24 \text{ cm}^2$.
 Calculate the area of the trapezium PQZY.

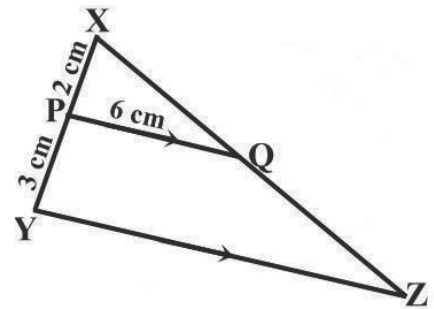

Lesson Title: Area of Compound Shapes	Theme: Mensuration
Practice Activity: PHM3-L008	Class: SSS 3
 Learning Outcome By the end of the lesson, you will be able to calculate the area of compound shapes using the appropriate formulae.	

Overview

This lesson reviews how to calculate the area of compound shapes.

Compound shapes are shapes made up of one or more different types of shapes.

They can be made up of a combination of triangles, squares, rectangles and other polygons.

The steps below show how to find the area of compound shapes.

- Divide the shape into triangles, squares and other regular polygons.
- Find any missing lengths of sides.
- Find the individual areas using the appropriate formula.
- Finally, add the areas together.

Solved Examples

1. Find the area of the given shape.

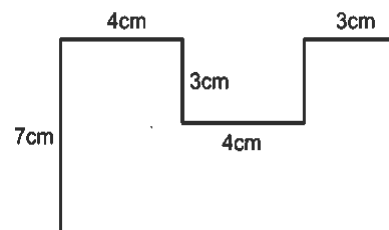

Solution:

$$\begin{aligned}
 \text{area of shape} &= \text{area of A} + \text{area of B} + \text{area of C} \\
 &= (7 \times 4) + (4 \times 4) + (7 \times 3) \\
 &= 28 + 16 + 21 \\
 &= 65 \text{ cm}^2
 \end{aligned}$$

The area of the shape is 65 cm².

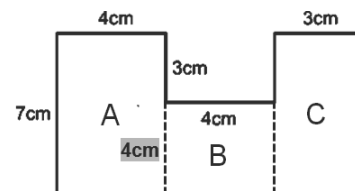

2. Find the area of the shapes shown in the diagrams below. All dimensions are in centimetres.

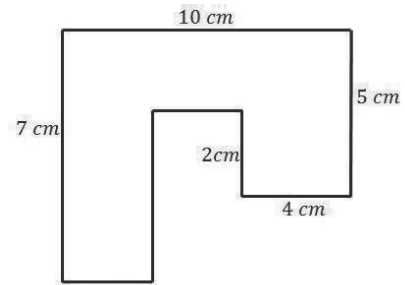

a. **Solution:**

b. **Solution:**

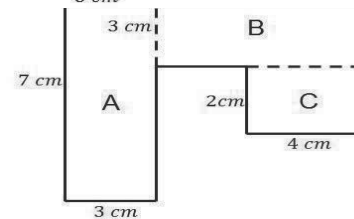

$$\begin{aligned} \text{Area of shape} &= \text{Area of A} + \text{area of B} + \text{area of C} \\ &= (7 \times 3) + (7 \times 3) + (4 \times 2) \\ &= 21 + 21 + 8 \\ &= 50 \text{ cm}^2 \end{aligned}$$

$$\begin{aligned} 5^2 &= 3^2 + h^2 \\ h^2 &= 25 - 9 \\ h^2 &= 16 \\ h &= \sqrt{16} \\ h &= 4 \end{aligned}$$

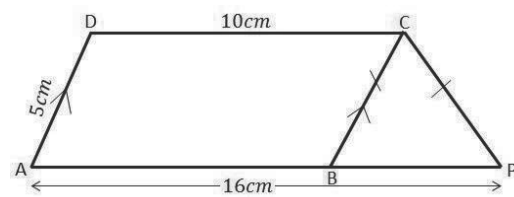

$$\begin{aligned} \text{Area of shape} &= \text{Area of ABCD} + \text{Area of } \triangle BPC \\ &= 10 \times 5 + \frac{1}{2} \times 6 \times 4 \\ &= 50 + 12 \\ &= 62 \text{ cm}^2 \end{aligned}$$

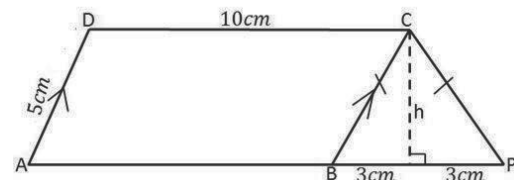

c. **Solution:**

$$\begin{aligned} \text{Area of semicircle} &= \frac{\pi r^2}{2} \\ &= \frac{22}{7} \times \frac{7^2}{2} \\ &= \frac{1,078}{14} \\ &= 77 \text{ cm}^2 \\ \text{Area of rectangle} &= L \times W \\ &= 18 \times 10 \\ &= 180 \text{ cm}^2 \end{aligned}$$

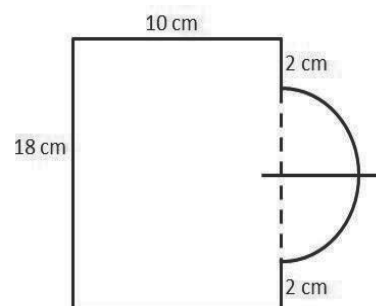

$$\begin{aligned}
 \text{Area of shape} &= \text{Area of semicircle} + \text{Area of rectangle} \\
 &= 180 \text{ cm}^2 + 77 \text{ cm}^2 \\
 &= 257 \text{ cm}^2
 \end{aligned}$$

d. **Solution:**

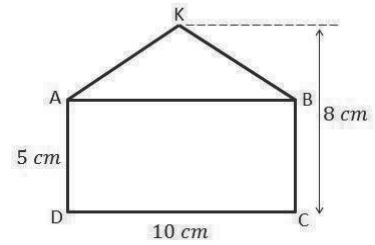

$$\begin{aligned}
 \text{Area of shape} &= \text{Area of ABCD} + \text{Area of } \triangle AKB \\
 &= 10 \times 5 + \frac{1}{2} \times 10 \times 3 \\
 &= 50 + 15 \\
 &= 65 \text{ cm}^2
 \end{aligned}$$

Practice

Find the area of the shapes shown in the diagrams below. All dimensions are in centimetres.

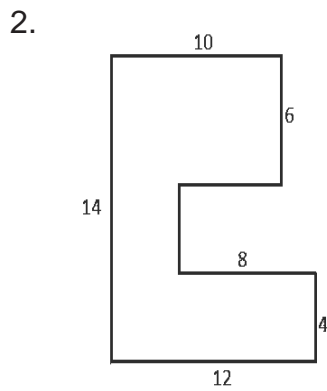
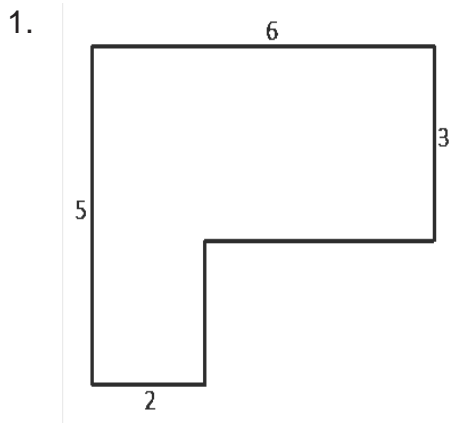

3.

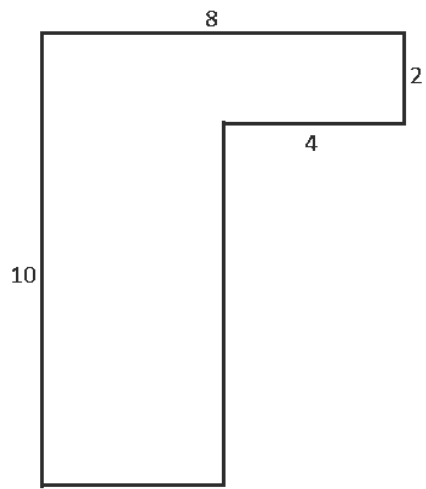

4.

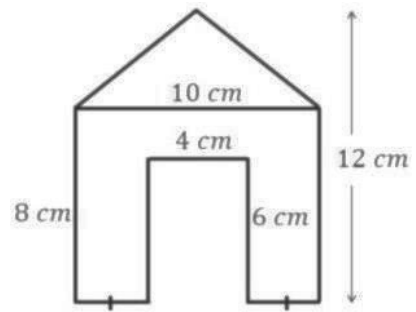

DIAGRAMS NOT TO SCALE

Lesson Title: Review of circles	Theme: Geometry
Practice Activity: PHM3-L009	Class: SSS 3
 Learning Outcomes By the end of the lesson, you will be able to: <ol style="list-style-type: none"> 1. Identify parts of a circle. 2. Calculate the circumference of a circle using the formula $C = 2\pi r$. 	

Overview

- This lesson is a review lesson on identifying the parts of a circle and calculating the circumference of a circle.
- The descriptions of the parts of a circle are shown in the diagram below.
- The circumference of a circle is given by the formula $C = 2\pi r$ where r is the radius of the circle.

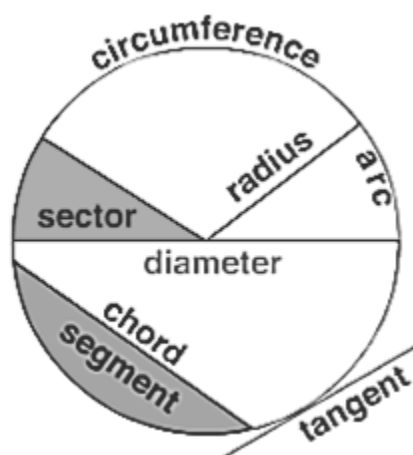

Parts of circle	Description
Circumference	The distance around a circle
Radius	The distance from the centre of the circle to any point on the circumference. It is also half of the diameter.
Diameter	A straight line passing through the centre of the circle to touch both sides of the circumference. It is also twice the length of the radius.
Chord	A straight line joining two points on the circumference of a circle. The diameter is a special kind of chord which passes through the centre of the circle.
Arc	A section of the circumference; part of the circumference of a circle.
Sector	A section of a circle bounded by two radii and an arc.
Segment	A section of a circle bounded by a chord and an arc.
Tangent	A straight line touching the circumference at a given point.
Semi-circle	Half of a circle.

Quadrant	Quarter of a circle.
-----------------	----------------------

Solved Examples

1. Find the circumference of a circle whose radius is 21 cm. Take $\pi = \frac{22}{7}$.

Solution:

$$\begin{aligned} C &= 2\pi r \\ &= 2 \times \frac{22}{7} \times 21 \end{aligned}$$

$$C = 132 \text{ cm}$$

The circumference of the circle is 132 cm.

2. The radius of a circle is 7 cm.
 a. What is the length of its diameter?
 b. What is the length of its circumference?

Solution:

$$r = 7 \text{ cm}$$

a. length of diameter = $2 \times 7 \text{ cm}$

length of diameter = 14 cm

b. circumference = $2\pi r$
 $= 2 \times \frac{22}{7} \times 7 \text{ cm}$
 $= \frac{308}{7}$
 $= 44 \text{ cm}$

3. A sports ground is circular in shape. If the diameter is 130 m, what is the distance around the field?

Diagram:

Solution:

$$\begin{aligned} r &= \frac{130 \text{ m}}{2} \\ &= 65 \text{ m} \\ \text{Distance round} &= 2 \times \frac{22}{7} \times 65 \text{ m} \\ \text{the field} &= \frac{2,860}{7} \text{ m} \\ &= 408.57 \text{ m} \end{aligned}$$

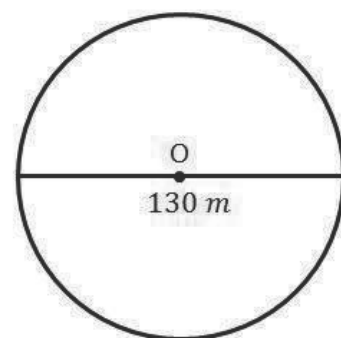

4. There are five lanes in a circular running track. The radius of the edge of the track is 80 m; the radius of the first lane is 75 m. What is the difference in the distances

run by two athletes if one runs around the edge of the track and the other runs around the first lane?

Solution:

$$\text{Distance of the edge of track} = 2 \times \frac{22}{7} \times 80 \text{ m}$$

$$= \frac{3,520}{7}$$

$$= 502.86 \text{ m}^2$$

$$\text{Distance of the first lane} = 2 \times \frac{22}{7} \times 75 \text{ m}$$

$$= \frac{3300}{7}$$

$$= 471.43 \text{ m}^2$$

$$\text{Difference} = \text{Distance of the edge of track} - \text{Distance of the first lane}$$

$$= 502.86 \text{ m}^2 - 471.43 \text{ m}^2$$

$$= 31.43 \text{ m}^2$$

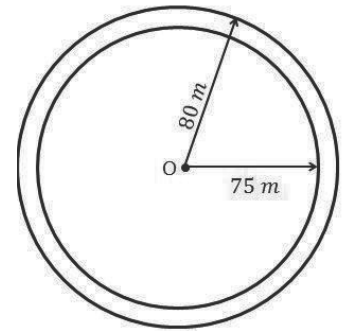

Practice

- Find the circumference of a circle with diameter 21 cm, using $\pi = \frac{22}{7}$
- Copy and fill in the table below. Use $\pi = \frac{22}{7}$.

No.	Radius	Diameter	Circumference
a)	12 m		
b)		42 m	
c)			616 mm
d)		126 mm	
e)	35 mm		
f)			77 m

- Mary's garden is circular in shape; its diameter is 7 m. If she plants rose trees 50 cm apart round the edge of the garden, how many rose trees does she need? Use $\pi = \frac{22}{7}$.

Lesson Title: Length of an arc	Theme: Geometry
Practice Activity: PHM3-L010	Class: SSS 3

	Learning Outcome By the end of the lesson, you will be able to calculate the length of an arc.
---	--

Overview

An arc is a part of the circumference of a circle.

The circle at right shows the arcs subtended by angles at the centre, O, of a circle.

- We know that the angle subtended by the circumference is 360° .
- We can see that 180° subtends half of the circle.
- Similarly, 90° subtends a quarter of the circle.
- From the table we can see that the length of the arc is proportional to the angle it subtends at the centre of the circle.
- The circumference subtends 360° and all other lengths of arcs are in proportion to the angles they subtend.
- **This means that if we take the ratio of the length of an arc to the circumference, it will be equal to the ratio of the angles subtended at the centre.**

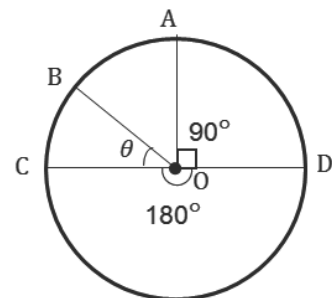

Angle subtended	Length of arc
360°	$2\pi r$
180°	πr
90°	$\frac{\pi r}{2}$

$$\frac{\text{length of arc}}{\text{circumference}} = \frac{\text{angle subtended by arc}}{360}$$

e.g. $\frac{\pi r}{2\pi r} = \frac{180}{360} = \frac{1}{2}$ Divide LHS by πr

And, $\frac{\frac{\pi r}{2}}{2\pi r} = \frac{90}{360} = \frac{1}{4}$

Similarly, $\frac{|AB|}{2\pi r} = \frac{\theta}{360}$ Where θ is the angle subtended by the arc AB

Therefore: $|AB| = \frac{\theta}{360} \times 2\pi r$

$$\text{Length of arc} = \frac{\theta}{360} \times 2\pi r$$

Solved Examples

1. An arc subtends an angle of 63° at the centre of a circle of radius 12 cm. Find the length of the arc. Use $\pi = \frac{22}{7}$.

Solution:

First draw a diagram of the problem (shown below).

$$\begin{aligned}
 |AB| &= \frac{\theta}{360} \times 2\pi r \\
 &= \frac{63}{360} \times 2 \times \frac{22}{7} \times 12 && \text{Substitute } \theta = 63, r = 12 \\
 &= \frac{63 \times 2 \times 22 \times 12}{360 \times 7} && \text{Simplify}
 \end{aligned}$$

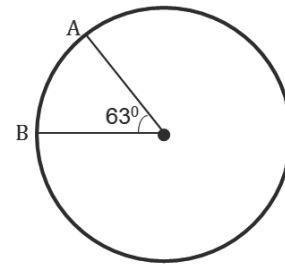

$$|AB| = 13.2 \text{ cm}$$

The length of the arc AB = 13.2 cm.

2. An arc of a circle with a radius of 7 cm is 14 cm long. What angle does the arc subtend at the centre of the circle? Give your answer to 1 decimal place. [Use $\pi = \frac{22}{7}$]

Solution:

$$\begin{aligned}
 \text{Length of arc} &= \frac{\theta}{360^\circ} \times 2\pi r \\
 14 \text{ cm} &= \frac{\theta}{360^\circ} \times 2 \times \frac{22}{7} \times 7 \text{ cm} \\
 \frac{14 \text{ cm}}{1} &= \frac{\theta \times 2 \times 22 \times 7}{360^\circ \times 7} \\
 1 \times \theta \times 2 \times 22 \times 7 &= \frac{360^\circ \times 7 \times 14}{35,280^\circ} \\
 \theta \times 308 &= \frac{35,280^\circ}{35,280^\circ} \\
 \theta &= \frac{308}{114.5^\circ}
 \end{aligned}$$

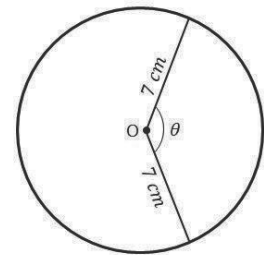

3. The angle subtended at the centre of a circle with a diameter of 8 cm is 135° . Find the length of the arc. Give your answer to 2 decimal places. [Use $\pi = \frac{22}{7}$]

Solution:

$$\begin{aligned}
 r &= \frac{d}{2} \\
 r &= \frac{8 \text{ cm}}{2} \\
 r &= 4 \text{ cm}
 \end{aligned}$$

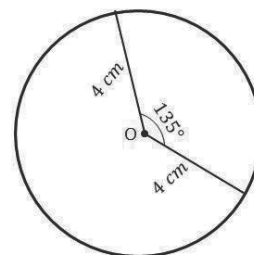

$$\begin{aligned}
 \text{Length of the arc} &= \frac{\theta}{360^\circ} \times 2\pi r \\
 \text{Length of the arc} &= \frac{135^\circ}{360^\circ} \times 2 \times \frac{22}{7} \times 4 \text{ cm} \\
 \text{Length of the arc} &= \frac{135 \times 2 \times 22 \times 4}{360 \times 7} \\
 \text{Length of the arc} &= \frac{23,760}{2,520} \\
 \text{Length of the arc} &= 9.43 \text{ cm}
 \end{aligned}$$

4. Find the length of the major arc PQ in the diagram below. Give your answer to 3 significant figures. [Use $\pi = \frac{22}{7}$]

Solution:

$$\begin{aligned}
 \text{Reflex of angle POQ} &= 360^\circ - 64^\circ \\
 \text{Reflex of angle POQ} &= 296^\circ \\
 \text{Length of arc PQ} &= \frac{\theta}{360^\circ} \times 2\pi r \\
 \text{Length of arc PQ} &= \frac{296^\circ}{360^\circ} \times 2 \times \frac{22}{7} \\
 &\quad \times 12 \text{ cm} \\
 \text{Length of arc PQ} &= \frac{296 \times 2 \times 22 \times 12}{360 \times 7} \\
 \text{Length of arc PQ} &= \frac{156,288}{2,520} \\
 \text{Length of arc PQ} &= 62.0 \text{ cm}
 \end{aligned}$$

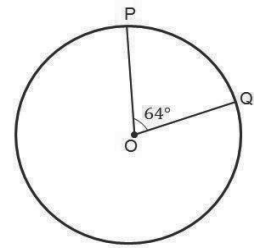

Practice

1. What angle does an arc of length 6.6 cm subtend at the centre of a circle of radius 21cm? [Use $\pi = \frac{22}{7}$]
2. Find the length of an arc with a radius of 12 cm if it subtends an angle of 120° at its centre. Give your answer to 2 significant figures. [Use $\pi = \frac{22}{7}$]
3. What angle does an arc with a length of 22 cm subtend at the centre of a circle with a radius of 14 m? [Use $\pi = \frac{22}{7}$]
4. Find the length of an arc with a radius of 15 cm if it subtends an angle of 146° at its centre. Give your answer to 2 decimal places. [Use $\pi = \frac{22}{7}$]

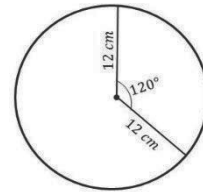
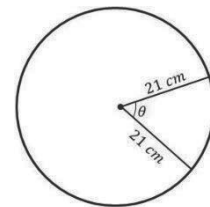

Lesson Title: Perimeter of a sector	Theme: Geometry
Practice Activity: PHM3-L011	Class: SSS 3

	<p>Learning Outcome By the end of the lesson, you will be able to calculate the perimeter of a sector of a circle.</p>
---	---

Overview

A circle with the centre, O , and radius, r is shown below:

- A sector of a circle is the region between two radii and an arc.
- AOB is a sector in the circle.
- The perimeter, P , of the sector is the distance around the sector.
- It is found by adding together the lengths of AO , OB and arc AB .

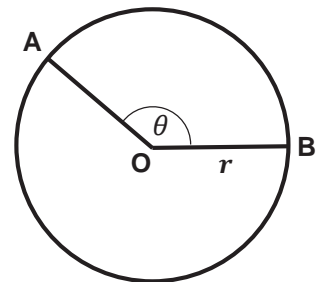

$$\begin{aligned}
 P &= |AO| + |OB| + |AB| \\
 &= 2 \times |OB| + |AB| && \text{since } |OB| = |AO| \\
 \text{but } |AB| &= \frac{\theta}{360} \times 2\pi r && \text{from last lesson} \\
 \therefore P &= 2r + \frac{\theta}{360} \times 2\pi r
 \end{aligned}$$

Solved Examples

1. An arc of a circle with a radius of 18 cm subtends an angle of 140° at the centre. What is the perimeter of the sector created by the arc?

Solution:

Using the circle above, let $|OB| = 18$ cm and $\theta = 140^\circ$, then

$$\begin{aligned}
 P &= |AO| + |OB| + |AB| \\
 &= 2 \times |OB| + |AB| && \text{since } |OB| = |AO| = 18 \text{ cm}
 \end{aligned}$$

We need to first find the length of arc AB

$$\begin{aligned}
 |AB| &= \frac{\theta}{360} \times 2\pi r \\
 &= \frac{140}{360} \times 2 \times \frac{22}{7} \times 18 && \text{Substitute } \theta = 140^\circ, r = 18 \text{ cm} \\
 &= \frac{140 \times 2 \times 22 \times 18}{360 \times 7} \\
 &= 44 \text{ cm}
 \end{aligned}$$

We can now find the perimeter of AOB

$$\begin{aligned}
 P &= (2 \times 18) + 44 \\
 &= 36 + 44 \\
 &= 80 \text{ cm}
 \end{aligned}$$

Substitute $|OB| = 18, |AB| = 44$

The perimeter of arc AOB = 80 cm.

2. The angle of a sector of a circle with a radius of 7 cm is 108° . Calculate the perimeter of the sector. (Use $\pi = \frac{22}{7}$)

Solution:

$$\begin{aligned}
 \text{radius of the sector} &= 7 \text{ cm} \\
 \text{angle of the sector} &= 108^\circ \\
 \text{Perimeter of the sector} &= 2r + \text{length of arc} \\
 &= 2r + \frac{\theta}{360^\circ} \times 2\pi r \\
 &= 2(7) + \frac{108^\circ}{360^\circ} \times 2 \times \frac{22}{7} \times 7 \\
 &= 14 + \frac{33,264}{2,520} \\
 &= 14 + 13.2 \\
 \text{Perimeter of the sector} &= 27.2 \text{ cm}
 \end{aligned}$$

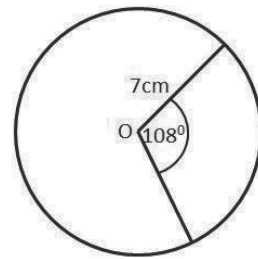

3. A rope with a length of 18 m is used to form a sector of a circle with a radius of 3.5 m on a school playing field. What is the size of the angle of the sector, correct to the nearest degree?

Use $\pi = \frac{22}{7}$

Solution:

$$\begin{aligned}
 \text{Perimeter of the sector} &= 18 \text{ cm} \\
 \text{radius of the sector} &= 3.5 \text{ cm} \\
 \text{angle of the sector} &= \theta \\
 \text{Perimeter of the sector} &= 2r + \frac{\theta}{360^\circ} \times 2\pi r \\
 18 &= 2(3.5) + \frac{\theta}{360^\circ} \times 2 \times \frac{22}{7} \times 3.5 \\
 18 &= 7 + \frac{\theta \times 154}{2,520^\circ} \\
 18 - 7 &= \frac{154\theta}{2,520^\circ} \\
 \frac{11}{1} &= \frac{154\theta}{2,520^\circ} \\
 1 \times 154\theta &= 11 \times 2,520^\circ \\
 154\theta &= 27,720^\circ \\
 \frac{154\theta}{154} &= \frac{27,720^\circ}{154}
 \end{aligned}$$

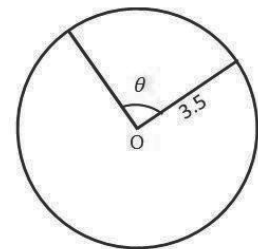

$$\theta = 180^\circ$$

The size of the angle of the sector = 180°

4. A sector of a circle with a radius of 6 cm subtends an angle of 105° at the centre of the circle. Calculate:
- The perimeter of the sector
 - The area of the sector (Use $\pi = \frac{22}{7}$)

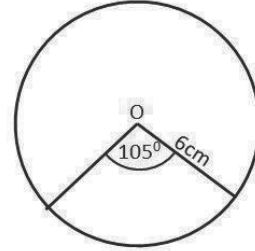

Solutions:

- radius of the sector = 6 cm
 angle of the sector = 105°
- a. Perimeter of the sector = $2(r) + \text{length of arc}$
 $= 2r + \frac{\theta}{360^\circ} \times 2\pi r$
 $= 2(6) + \frac{105^\circ}{360^\circ} \times 2 \times \frac{22}{7} \times 6$
 $= 12 + \frac{27,720}{2,520}$
 $= 12 + 11$
 Perimeter of the sector = 23 cm
- b. Area of the sector = $\frac{\theta}{360^\circ} \times \pi r^2$
 $= \frac{105^\circ}{360^\circ} \times \frac{22}{7} \times 6^2$
 $= \frac{83,160}{2,520}$
 Area of the sector = 33 cm^2

Practice

- A sector of a circle with a radius of 14 cm subtends an angle of 135° at the centre of the circle. What is the perimeter of the sector? (Use $\pi = \frac{22}{7}$)
- The angle of a sector is 70° . If the diameter of the circle is 28 mm, find:
 - The area of the sector correct to 3 significant figures.
 - The perimeter of the sector. Give your answer to 1 decimal place. (Use $\pi = 3.142$)
- A sector of a circle with a radius of $3\frac{1}{2}$ cm subtends an angle of 108° at the centre of the circle. What is the perimeter of the sector? Give your answer to 2 decimal places (Use $\pi = 3.142$)
- The angle of a sector of a circle of radius 10.5 cm is 120° . Calculate the perimeter of the sector. Give your answer to 2 significant figures (Use $\pi = 3.142$)

5. A sector of a circle with a radius of 7 cm subtends an angle of 270° at the centre.

Calculate:

a. The length of the arc

b. The perimeter of the sector (use $\pi = \frac{22}{7}$)

Lesson Title: Perimeter of a segment	Theme: Geometry
Practice Activity: PHM3-L012	Class: SSS 3



Learning Outcome

By the end of the lesson, you will be able to calculate the perimeter of a segment of a circle.

Overview

A circle with centre, O , and radius, r is shown at right:

- AB is a segment in the circle.
- A segment of a circle is the region between the chord AB and the arc AB .
- The perimeter, P , of the segment is the distance around the shaded area in the diagram.
- It is found by adding together the lengths of the chord AB and the arc AB .

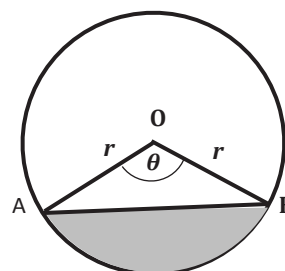

$$P = \text{chord } AB + \text{arc } AB$$

$$\text{arc } |AB| = \frac{\theta}{360} \times 2\pi r$$

- The chord length is either given in the problem or can be found using Trigonometry or Pythagoras' Theorem.

Solved Examples

- Let $r = 12$ cm and $\theta = 120^\circ$ in the diagram shown. Find
 - the length of chord AB ;
 - the length of the arc AB ;
 - the perimeter of segment AB . Give your answers to 1 decimal place. Use $\pi = 3.14$.

Solution:

- Draw a perpendicular line from the centre of the circle to the chord AB .
- This bisects (divides in half) both the angle at the centre and the chord giving 2 equal right-angled triangles, OCA and OCB .

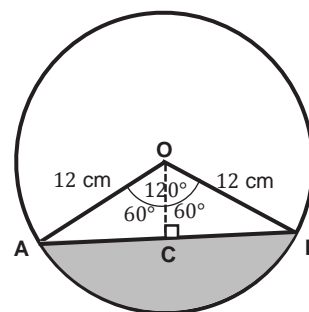

$$\text{a. } \sin 60^\circ = \frac{|CB|}{12}$$

$$\begin{aligned} |CB| &= 12 \times \sin 60^\circ \\ &= 12 \times 0.8660 \\ &= 10.392 \end{aligned}$$

Use sine ratio to find the length of CB

$$\text{Note: } \angle AOC = \frac{\angle AOB}{2} = \frac{120}{2} = 60^\circ$$

$\sin 60^\circ = 0.8660$ from the sine table

$$\begin{aligned}
 |CB| &= 10.4 \text{ cm} \\
 |AB| &= |AC| + |CB| \\
 &= 2 \times |CB| && \text{Since } |AC| = |CB| \\
 &= 2 \times 10.4 \\
 &= 20.8 \text{ cm}
 \end{aligned}$$

The length of the chord $|AB| = 20.8 \text{ cm}$ to 1 decimal place

Note: For a given angle at the centre, the length of the chord will

always be $2 \times \text{radius} \times \sin\left(\frac{\text{angle at centre}}{2}\right)$

$$\begin{aligned}
 \text{b. arc } |AB| &= \frac{\angle AOC}{360} \times 2\pi r \\
 &= \frac{120}{360} \times 2 \times 3.14 \times 12 && \text{Substitute } \angle AOC = 120, r = 12 \\
 &= 25.12 && \text{Simplify}
 \end{aligned}$$

$$\text{arc } |AB| = 25.1 \text{ cm}$$

The length of arc $|AB| = 25.1 \text{ cm}$ to 1 decimal place

$$\begin{aligned}
 \text{c. Let } P &= \text{perimeter of sector AB} \\
 &= \text{chord } |AB| + \text{arc } |AB| \\
 &= 20.8 + 25.1 = 45.9 \text{ cm}
 \end{aligned}$$

The perimeter of sector $AB = 45.9 \text{ cm}$ to 1 decimal place

2. A chord with a length of 30 cm is 8 cm away from the centre of the circle. What is the radius of the circle?

Solution:

$$\begin{aligned}
 AB &= \text{length of the chord} \\
 AD &= DB = \frac{AB}{2} \\
 AO^2 &= OD^2 + AD^2 \\
 r^2 &= 8^2 + 15^2 \\
 r^2 &= 64 + 225 = 289 \\
 r &= \sqrt{289} = 17 \text{ cm}
 \end{aligned}$$

The radius of the circle is 17 cm.

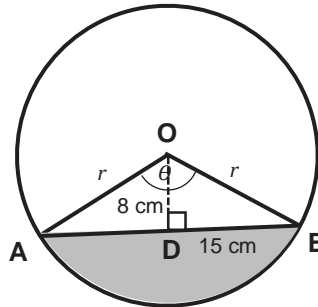

3. A chord is 5 cm from the centre of a circle which has a diameter of 26 cm. Find the length of the chord. (Use $\pi = \frac{22}{7}$)

Solution:

$$\begin{aligned}
 AB &= \text{length of the chord} \\
 AC = BC &= \frac{AB}{2} \\
 2r &= d \\
 r &= \frac{d}{2} = \frac{26}{2} \\
 r &= 13 \text{ cm}
 \end{aligned}$$

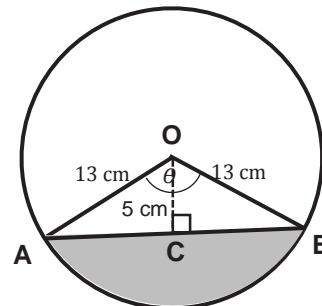

Consider $\triangle BOC$

$$\begin{aligned} OB^2 &= OC^2 + BC^2 \\ 13^2 &= 5^2 + BC^2 \\ 169 &= 25 + BC^2 \\ 169 - 25 &= BC^2 \\ 144 &= BC^2 \\ BC &= \sqrt{144} = 12 \text{ cm} \\ AB &= 2BC \\ &= 2 \times 12 = 24 \text{ cm} \end{aligned}$$

The length of the chord is 24 cm

4. A chord of a circle is 120 cm long. The perpendicular distance of this chord from the centre of the circle is 25 cm.

Calculate:

- The radius of the circle.
- The angle subtended by the chord at the centre of the circle to 0.1° .

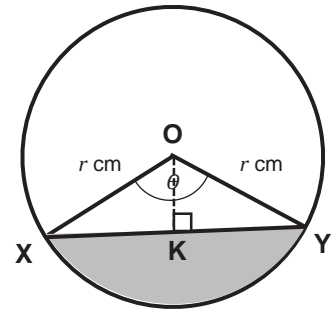

Solutions:

$$\begin{aligned} \text{a.} \quad XY &= \text{length of chord} \\ KX = KY &= \frac{XY}{2} \\ \angle XOY &= \angle XOK + \angle YOK \\ &= \theta \\ \angle XOK = \angle YOK &= \frac{\theta}{2} \\ \text{From } \triangle YOK &= \\ OY^2 &= OK^2 + KY^2 \\ r^2 &= 25^2 + 60^2 \\ r^2 &= 625 + 3,600 = 4,225 \\ r &= \sqrt{4,225} \\ r &= 65 \text{ cm} \end{aligned}$$

The radius of the circle is 65 cm.

$$\begin{aligned} \text{b.} \quad \tan \frac{\theta}{2} &= \frac{60}{25} \\ \tan \frac{\theta}{2} &= 2.4 \\ \frac{\theta}{2} &= \tan^{-1} 2.4 \\ \frac{\theta}{2} &= 67.38^\circ \\ \theta &= 2 \times 67.38^\circ \\ \theta &= 134.8^\circ \end{aligned}$$

The angle subtended by the chord at the centre of the circle is 134.8° .

Practice

1. The angle subtended at the centre by a chord of a circle with a radius of 6 cm is 120° . Find: a. the length of the chord; b. the length of the arc; c. the perimeter of the segment. Use $\pi = \frac{22}{7}$)
2. Find the perimeter of the segment of a circle with a radius of 7 cm if the chord subtends an angle of 270° at the centre.
3. A circle has a radius of 5 cm. A chord of the circle has a length of 8 cm. Find:
 - a. The angle of the chord that subtends the centre of the circle to the nearest degree.
 - b. The perimeter of the segment.
4. A chord divides a circle with a radius of 2 m into two segments. If the chord subtends an angle of 60° at the centre of the circle, find the perimeter of the segment.

Lesson Title: Area of a circle	Theme: Geometry
Practice Activity: PHM3-L013	Class: SSS 3

	<p>Learning Outcome By the end of the lesson, you will be able to calculate the area of a circle using the formula $A = \pi r^2$.</p>
---	---

Overview

- This lesson is a review lesson on identifying the parts of a circle and calculating the area of a circle.
- The area of a circle is given by the formula $A = \pi r^2$ where r is the radius of the circle.

Solved Examples

1. A circle has a diameter of 4.2 m, find the area of the circle. Give your answer to 2 decimal places. (Use $\pi = 3.14$)

Solution:

$$\begin{aligned}
 A &= \pi r^2 \\
 d &= 2r \\
 r &= \frac{d}{2} \\
 &= \frac{4.2}{2} = 2.1 && \text{Substitute } d = 4.2
 \end{aligned}$$

We can now find the area of the circle

$$\begin{aligned}
 A &= \pi r^2 \\
 &= 3.14 \times 2.1^2 && \text{Substitute } r = 2.1 \\
 &= 13.847 \text{ cm}^2
 \end{aligned}$$

The area of the circle = 13.85 cm² to 2 d.p.

2. Find the area of a circle with a radius of 12 cm. Give your answer to 1 decimal place.

Solution:

$$\begin{aligned}
 \text{Radius} &= 12 \text{ cm} \\
 \text{Area of the circle} &= \pi r^2 \\
 &= \frac{22}{7} \times 12^2 \\
 &= \frac{3168}{7} \\
 &= 452.57
 \end{aligned}$$

$$\text{Area of the circle} = 452.6 \text{ cm}^2$$

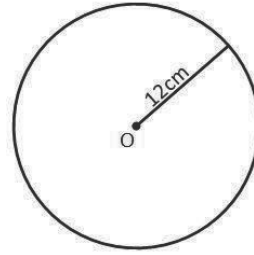

3. The area of a circular track is 1386 cm^2 . Find its radius, r , correct to the nearest metre. (Use $\pi = \frac{22}{7}$)

Solution:

$$\begin{aligned} \text{Area of circle} &= 1386 \text{ cm}^2 \\ \text{Area of circle} &= \pi r^2 \\ 1386 &= \frac{22}{7} \times r^2 \\ \frac{1386}{1} &= \frac{22 \times r^2}{7} \\ 1 \times 22 \times r^2 &= 1386 \times 7 \\ 22 \times r^2 &= 9702 \\ \frac{22 \times r^2}{22} &= \frac{9702}{22} \\ r^2 &= 441 \\ r &= \sqrt{441} \\ r &= 21 \end{aligned}$$

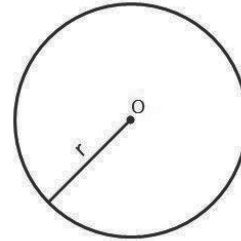

The radius of the circular track = 21 cm

4. Find the area of the shaded portion in the figure shown.

Solution:

$$\begin{aligned} \text{radius of the outer circle (R)} &= \frac{10}{2} = 5 \text{ cm} \\ \text{radius of the inner circle (r)} &= \frac{5}{2} = 2.5 \text{ cm} \\ \text{Area of the shaded portion} &= \text{Area of the outer circle} - \text{area of the inner circle} \\ \text{Area of the shaded portion} &= \pi R^2 - \pi r^2 \\ &= \frac{22}{7} \times 5^2 - \frac{22}{7} \times 2.5^2 \\ &= \frac{550}{7} - \frac{137.5}{7} \\ &= 78.57 - 19.64 \\ \text{Area of the shaded portion} &= 58.93 \text{ cm}^2 \end{aligned}$$

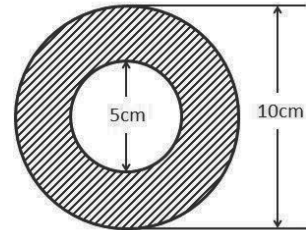

Practice

Use $\pi = \frac{22}{7}$ unless otherwise stated.

1. Find the area of a circle with a radius of 18 cm .Give your answer to 2 decimal places.
2. The area of a circular track is 616 cm^2 . Find the radius of the track.
3. The area of a circle is 38.5 cm^2 . Find its diameter.
4. Find the area of the shaded portion in the figure shown at right. Give your answer to the nearest whole number.

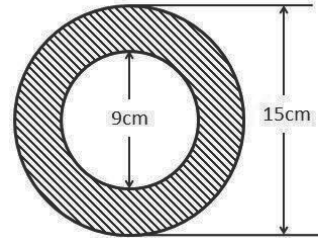

Lesson Title: Area of a sector	Theme: Geometry
Practice Activity: PHM3-L014	Class: SSS 3

	<p>Learning Outcome By the end of the lesson, you will be able to calculate the area of a sector of a circle.</p>
---	--

Overview

From our previous lesson on the lengths of arcs:

- We know that the lengths of the arc in a circle are proportional to the angles they subtend at the centre of the circle.
- In the same way, the area of a sector of a circle is proportional to the angle of the sector.
- The circle is a sector with an angle of 360° and area πr^2 .
- All other sectors have areas in proportion to the angle of the sector.
- **This means that if we take the ratio of the area of a sector to the area of the circle, it will be equal to the ratio of the angles off the sector.**

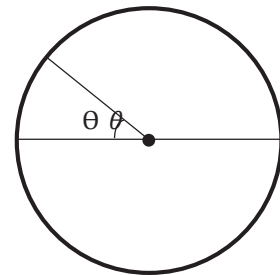

$$\frac{\text{area of sector}}{\text{area of circle}} = \frac{\text{angle of sector}}{360}$$

Let A = area of sector, θ = angle of sector

$$\frac{A}{\pi r^2} = \frac{\theta}{360}$$

$$A = \frac{\theta}{360} \times \pi r^2$$

$$\text{area of sector} = \frac{\theta}{360} \times \pi r^2$$

Solved Examples

1. An arc subtends an angle of 63° at the centre of a circle with a radius of 12 cm. Find the area of the sector correct to the nearest cm^2 . (Use $\pi = 3.14$)

Solution:

First draw a diagram of the problem (shown below).

$$A = \frac{\theta}{360} \times \pi r^2$$

$$= \frac{63}{360} \times 3.14 \times 12^2$$

$$= 79.128$$

Substitute $\theta = 63^\circ, r = 12$

Simplify

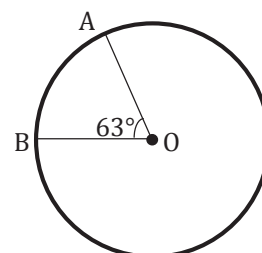

$$A = 79 \text{ cm}^2$$

The area of the sector to the nearest $\text{cm}^2 = 79 \text{ cm}^2$.

2. The angle of a sector of a circle with a diameter of 8 cm is 135° . Find the area of the sector. (Use $\pi = \frac{22}{7}$)

Solution:

$$\begin{aligned} \text{Diameter} &= 8 \text{ cm} \\ \text{Angle of the sector} &= 135^\circ \\ 2r &= d \\ r &= \frac{d}{2} \\ &= \frac{8}{2} \\ r &= 4 \text{ cm} \\ \text{Area of the sector} &= \frac{\theta}{360^\circ} \times \pi r^2 \\ &= \frac{135^\circ}{360^\circ} \times \frac{22}{7} \times 4^2 \\ &= \frac{47,520}{2,520} \\ \text{Area of the sector} &= 18.86 \text{ cm}^2 \end{aligned}$$

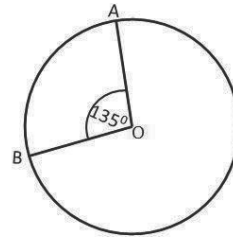

3. A sector of a circle with a radius of 7 cm has an area of 44 cm^2 . Calculate the angle of the sector, correct to the nearest degree. (Use $\pi = \frac{22}{7}$)

Solution:

$$\begin{aligned} \text{Radius} &= 7 \text{ cm} \\ \text{Angle of the sector} &= \theta \\ \text{Area of the sector} &= 44 \text{ cm}^2 \\ \text{Area of the sector} &= \frac{\theta}{360^\circ} \times \pi r^2 \\ 44 &= \frac{\theta}{360^\circ} \times \frac{22}{7} \times 7^2 \\ 44 &= \frac{\theta \times 1,078}{2,520^\circ} \\ 1 \times \theta \times 1,078 &= 44 \times 2,520^\circ \\ \theta \times 1,078 &= 110,880^\circ \\ \frac{\theta \times 1,078}{1,078} &= \frac{110,880^\circ}{1,078} \\ \theta &= 102.86^\circ \\ \theta &= 103^\circ \end{aligned}$$

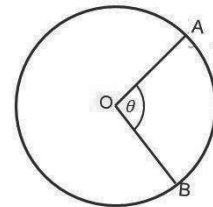

Practice

Use $\pi = \frac{22}{7}$ unless otherwise stated.

1. The angle of a sector of a circle with a diameter of 23 cm is 150° . Find the area of the sector. Give your answer to 1 decimal place.
2. The angle of a sector of a circle with a radius of 10.5 cm is 144° . Find the area of the sector. Give your answer to 3 significant figures.
3. A sector of a circle with a radius of 13 cm has an area 64.6 cm^2 . Calculate the angle of the sector, correct to the nearest degree.
4. A sector of a circle with a radius of 17 cm has an area 75 cm^2 . Calculate the angle of the sector, correct to the nearest degree.
5. The area of the sector of a circle is 114 cm^2 . If the angle of the sector is 108° , find the radius of the circle to the nearest whole number.
6. The area of the sector of a circle is 112 cm^2 . If the angle of the sector is 176° , find the radius of the circle to 3 significant figures.

Lesson Title: Area of a Segment	Theme: Geometry
Practice Activity: PHM3-L015	Class: SSS 3



Learning Outcome

By the end of the lesson, you will be able to calculate the area of a segment of a circle.

Overview

The diagram at the right shows a circle with a radius of r , and center, O . From the diagram, we see that the area of the segment of a circle is given by:

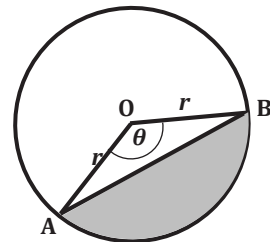

$$\begin{aligned} \text{area of segment AB} &= \text{area of sector OAB} - \text{area of triangle OAB} \\ \text{area of sector OAB} &= \frac{\theta}{360} \times \pi r^2 \\ \text{area of segment AB} &= \frac{\theta}{360} \times \pi r^2 - \frac{1}{2} r^2 \sin \theta \end{aligned}$$

Solved Examples

1. The circle shown at the right has a radius of 10 cm. An arc subtends an angle of 75° at the center of the circle. Find the area of the segment AB. Use $\pi = 3.14$. Give your answer to 2 significant figures.

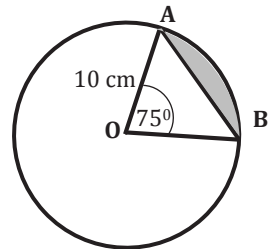

Solution:

$$\begin{aligned} \text{area of segment AB} &= \frac{\theta}{360} \times \pi r^2 - \frac{1}{2} r^2 \sin \theta \\ \text{area of sector OAB} &= \frac{75}{360} \times 3.14 \times 10^2 && \text{Substitute } \theta = 75, r = 10 \\ &= 65.42 \text{ cm}^2 && \text{Simplify} \\ \text{area of triangle OAB} &= \frac{1}{2} 10^2 \times \sin 75 && \text{Substitute } \theta = 75, r = 10 \\ &= 48.30 \text{ cm}^2 && \text{Simplify} \\ \text{area of segment AB} &= 65.42 - 48.30 \\ &= 17.12 \end{aligned}$$

The area of the segment AB = 17 cm² to 2 s.f.

2. In the diagram at the right, O is the center of the circle with a radius of 3.2 cm. If $\angle PRQ = 42^\circ$, calculate, correct to two decimal places, the area of the: i) minor sector ii) the shaded part.

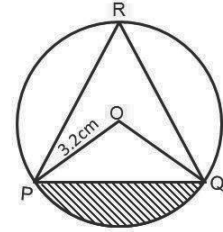

Solution:

$$\begin{aligned}
 2 \times \angle PRQ &= \angle POQ \\
 2 \times 42^\circ &= \angle POQ \\
 84^\circ &= \angle POQ \\
 \text{Area of the minor sector PO} &= \frac{\theta}{360^\circ} \times \pi r^2 \\
 &= \frac{84^\circ}{360^\circ} \times \frac{22}{7} \times 3.2^2 \\
 &= \frac{18,923.52}{2,520} \\
 &= 7.51 \text{ cm}^2 \\
 \text{Area of the shaded part} &= \text{Area of sector PQ} \\
 &= \text{area of minor sector POQ} - \text{area of } \triangle POQ \\
 \text{Area of } \triangle POQ &= \frac{1}{2} \times 3.2 \times 3.2 \times \sin 84^\circ \\
 &= 5.09 \text{ cm}^2 \\
 \text{Area of the shaded part} &= 7.51 - 5.09 \\
 &= 2.42 \text{ cm}^2
 \end{aligned}$$

3. Calculate the area of the shaded segment of the circle shown in the diagram below. (Use $\pi = \frac{22}{7}$)

Solution:

$$\begin{aligned}
 \text{Area of the shaded segment} &= \text{Area of sector OAB} - \text{Area } \triangle OAB \\
 \text{Area of sector OAB} &= \frac{\theta}{360^\circ} \times \pi r^2 \\
 &= \frac{63^\circ}{360^\circ} \times \frac{22}{7} \times 10^2 \\
 &= \frac{138,600}{2,520} \\
 &= 55 \text{ cm}^2 \\
 \text{Area } \triangle OAB &= \frac{1}{2} \times 10 \times 10 \times \sin 63^\circ \\
 &= 44.55 \text{ cm}^2 \\
 \text{Area of the shaded segment} &= \text{Area of sector OAB} - \text{Area } \triangle OAB \\
 &= 55 - 44.55 \\
 \text{Area of the shaded segment} &= 10.45 \text{ cm}^2
 \end{aligned}$$

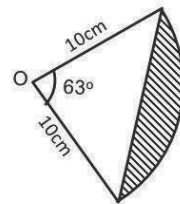

4. The diagram below shows the shaded segment of a circle of radius 7cm. if the area of triangle OXY is $12\frac{1}{4} \text{ cm}^2$, calculate the area of the segment. (Use $\pi = \frac{22}{7}$)

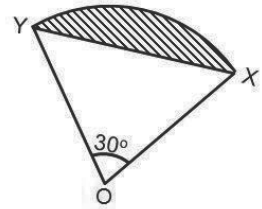

Solution:

$$\begin{aligned}
 \text{Area of the shaded segment} &= \text{Area of sector XOY} - \text{Area } \triangle XOY \\
 &= \frac{\theta}{360^\circ} \times \pi r^2 - 12\frac{1}{4} \\
 &= \frac{30^\circ}{360^\circ} \times \frac{22}{7} \times 7^2 - 12\frac{1}{4} \\
 &= \frac{32,340}{2,520} - \frac{49}{4} \\
 &= \frac{77}{6} - \frac{49}{4} \\
 \text{Area of the shaded segment} &= \frac{7}{12} \text{ cm}^2
 \end{aligned}$$

Practice

1. The diagram shows the shaded segment of a circle of radius 9 cm, if the angle subtended by the minor arc is 140° . Calculate the area of the Segment. (Use $\pi = 3.142$).

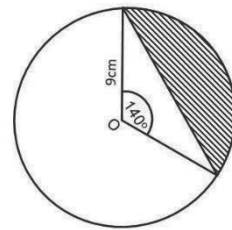

2. A chord of a circle of radius 18 cm subtends an angle 135° at the centre of the circle. Find the area of the segment bounded by the chord and the minor arc. (Use $\pi = 3.142$). Give your answer to 3 significant figures.

3. The diagram shows the shaded segment of a circle of radius 12cm, if the area of the triangle OPQ is 24.63 cm^2 , calculate the area of the segment. (Use $\pi = \frac{22}{7}$)

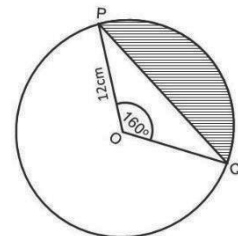

Lesson Title: Area and perimeter of composite shapes	Theme: Mensuration
Practice Activity: PHM3-L016	Class: SSS 3
 Learning Outcome By the end of the lesson, you will be able to solve problems involving areas and perimeters of composite shapes.	

Overview

This lesson reviews how to calculate the perimeters and areas of composite shapes.

Composite shapes are shapes made up of one or more different types of shapes. They can be made up of a combination of circles, triangles, rectangles and other polygons.

The steps below show how to find the perimeter and area of a composite shape.

- Divide the shape into its individual parts.
- Find any missing lengths of sides.
- Find the individual areas or perimeters using the appropriate formula.
- Add the areas or perimeters together.

Solved Examples

1. Find the area and perimeter of the given shape. Round answers to the nearest cm or cm^2 . Take $\pi = 3.14$.

Solution:

Divide the shape into a rectangle A and a semi-circle B.

$$\text{perimeter of shape} = \text{perimeter of A} + \text{perimeter of B}$$

$$\begin{aligned} \text{perimeter of A} &= 2l + w \\ &= (2 \times 160) + 80 \\ &= 320 + 80 \\ &= 400 \text{ cm} \end{aligned}$$

$$\begin{aligned} \text{perimeter of B} &= \pi r \\ &= 3.14 \times 40 \\ &= 125.6 \text{ cm} \end{aligned}$$

$$\begin{aligned} \text{perimeter of shape} &= 400 + 125.6 \\ &= 525.6 \\ &= 526 \text{ cm to the nearest cm} \end{aligned}$$

since the top line of the rectangle (length 80 cm) is not counted

B is a semi-circle, half of the perimeter of a circle

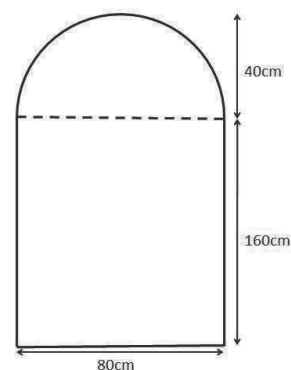

The perimeter of the shape is 526 cm to the nearest cm.

$$\text{area shape} = \text{area of A} + \text{area of B}$$

$$\begin{aligned} \text{area of A} &= lw \\ &= 160 \times 80 \\ &= 12,800 \text{ cm}^2 \end{aligned}$$

$$\begin{aligned} \text{area of B} &= \frac{1}{2} \times \pi r^2 && \text{B is a semi-circle} \\ &= \frac{1}{2} \times 3.14 \times 40^2 \end{aligned}$$

$$\begin{aligned} \text{area of shape} &= 12,800 + 2512 \\ &= 15,313 \end{aligned}$$

The area of the shape is 15,313 cm² to the nearest cm².

2. Consider the diagram below representing a field with a circular pond of diameter 14 m. Find:

- The distance around the field.
- The area of the field excluding the pond.
(Take $\pi = \frac{22}{7}$)

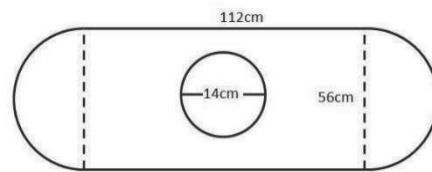

Solutions:

$$\begin{aligned} \text{a. distance around the field} &= \text{Perimeter of two semi-circles} + 2 \times \text{length of the rectangle} \\ \text{radius of the semi-circle} &= \frac{56}{2} = 28 \text{ cm} \\ \text{perimeter of the two semi-circles} &= 2 \times \pi r \\ &= 2 \times \frac{22}{7} \times 28 \\ &= 176 \text{ cm} \\ 2 \times \text{length of the rectangle} &= 2 \times 112 \\ &= 224 \text{ cm} \\ \text{distance around the field} &= 176 + 224 \\ &= 400 \text{ cm} \end{aligned}$$

$$\begin{aligned} \text{b. area of the field excluding the pond} &= \text{Area of the field} - \text{area of the pond} \\ \text{area of field} &= \text{Area of the two semi-circles} + \text{area of the rectangle} \\ &= 2 \left(\frac{\pi r^2}{2} \right) + lw \\ &= \frac{22}{7} \times 28^2 + 112 \times 56 \\ &= 2,464 + 6,272 \\ &= 8,736 \text{ cm}^2 \\ \text{area of the pond} &= \pi r^2 \end{aligned}$$

$$\begin{aligned}
 \text{radius of the pond} &= \frac{14}{2} = 7 \\
 &= \frac{22}{7} \times 7^2 \\
 &= 154 \text{ cm}^2 \\
 \text{area of the field excluding the pond} &= 8,736 - 154 \\
 &= 8,582 \text{ cm}^2
 \end{aligned}$$

Practice

1. A shield is in the form a rectangle ABCD, 12 cm by 10 cm and a semi-circle with DC as a diameter. Calculate the area of the shield.

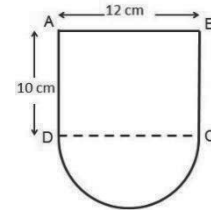

2. The diagram below shows the shape of a work surface. It is made from a rectangle of sides 40 cm and 68 cm and half a circle of diameter 40 cm. Calculate the area of the work surface.

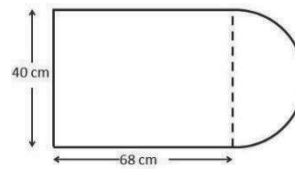

3. The diagram shows a wooden structure in the form of a cone mounted on a hemispherical base. The vertical height of the cone is 24 cm and the base radius is 7 cm. Calculate to 3 significant figures, the surface area of the structure. [Take $\pi = 3.142$]

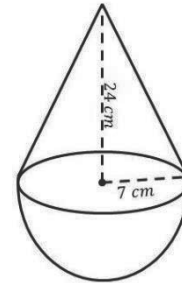

4. Find the area of the shapes shown in the diagrams below:

a.

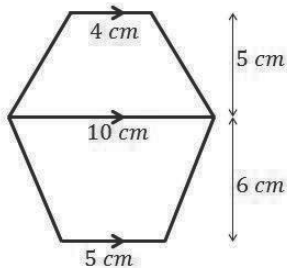

b.

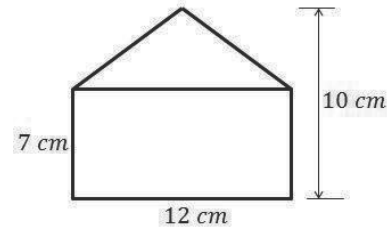

5. The diagram below shows a triangular metal plate with sides of 4.5 cm, 6 cm and 7.5 cm. It has three small circular holes with a radius of 4 mm. Calculate the area of the metal plate to the nearest square centimetre.

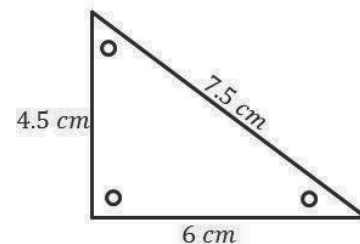

Lesson Title: Circle Theorem 1	Theme: Geometry
Practice Activity: PHM3-L017	Class: SSS 3
 Learning Outcome By the end of the lesson, you will be able to identify and demonstrate: A straight line from the centre of a circle that bisects a chord is at right angles to the chord.	

Overview

In Geometry, rules or **theorems** are used to determine the lengths and angles in circles. These theorems are true for every circle regardless of the size of the circle.

In the next few lessons, we will give a simple proof for each theorem we meet. We will use them together with theorems on triangles and other polygons to help us find missing sides and angles in circles.

For each theorem, we will:

- Write the formal statement for the theorem.
- Draw the diagram of the situation we wish to prove.
- State the information we are given in the diagram.
- Write the Mathematical statement we are going to prove in the theorem.
- Give the proof of the theorem.

We have numbered the theorems in the order we will be working with them. They may be numbered differently in other textbooks. The first theorem deals with the perpendicular bisector of a chord from the centre of a circle.

Circle Theorem 1

A straight line from the centre of a circle that bisects a chord is at right angles to the chord

Given: Circle with centre O and line OM to mid-point M on chord PQ such that $|PM| = |QM|$.

To prove: $OM \perp PQ$

Proof:

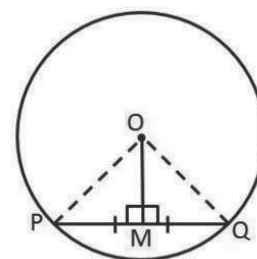

In both $\triangle OMP$ and $\triangle OMQ$

$$\begin{array}{lll}
 |OP| & = & |OQ| & \text{equal radii} \\
 |PM| & = & |QM| & \text{Given} \\
 |OM| & = & |OM| & \text{common side} \\
 \therefore \triangle OMP & = & \triangle OMQ & \text{SSS} \\
 \therefore \angle OMP & = & \angle OMQ &
 \end{array}$$

$$\begin{aligned}\angle OMP + \angle OMQ &= 180^\circ && \text{angles on a straight line} \\ \therefore \angle OMP = \angle OMQ &= 90^\circ\end{aligned}$$

Therefore $OM \perp PQ$ line from centre to mid-point \perp

- The proof shows step by step how we use previous knowledge from triangles to find the required result.
- We give reasons for the Mathematical statement we make by using a known fact, e.g. OA and OB are equal radii, or angles on a straight line = 180° .
- When we solve problems we are often asked to give reasons for our answers.
- Use the statement “**line from centre to mid-point \perp** ” when using this theorem to solve circle problems.
- The \perp means “is perpendicular” or “is at right angles” to the chord.

There are 2 converse theorems which refer to line OM the perpendicular bisector.

- If a line is drawn from the centre of a circle perpendicular to a chord, then it bisects the chord. Use the statement “ **\perp from centre bisects chord**” when using this theorem to solve circle problems.
- If the perpendicular bisector of a chord is drawn, then the line will pass through the centre of the circle. Use the statement “ **\perp bisector passes through centre**” when using this theorem to solve circle problems.

Solved Examples

1. The radius of a circle is 12 cm. The length of a chord of the circle is 18 cm. Calculate the distance of the mid-point of the chord from the centre of the circle. Give your answer to the nearest cm.

Solution:

Using the circle from the proof:

M	$=$	mid-point of PQ	
$ MQ $	$=$	9 cm	$\frac{1}{2} \times PQ = \frac{18}{2} = 9$
$\angle OMQ$	$=$	90°	line from centre to mid-point \perp
$ OQ ^2$	$=$	$ OM ^2 + MQ ^2$	Pythagoras Theorem
12^2	$=$	$ OM ^2 + 9^2$	substitute $ OQ = 12$ cm, $ MQ = 9$ cm
$ OM ^2$	$=$	$12^2 - 9^2$	
	$=$	$144 - 81$	
$ OM $	$=$	$\sqrt{63} = 7.94$	
$ OM $	$=$	8 cm	

The distance from the mid-point of the chord to the centre of the circle is 8 cm to the nearest cm.

2. A chord is 5 cm from the centre of a circle of diameter 26 cm. Find the length of the chord.

Solution:

$$\begin{aligned}r &= \frac{26}{2} \\r &= 13 \text{ cm} \\ \text{From } \triangle OBT \\ OB^2 &= OT^2 + BT^2 \\ 13^2 &= 5^2 + BT^2 \\ 169 &= 25 + BT^2 \\ 169 - 25 &= BT^2 \\ 144 &= BT^2 \\ BT &= 12 \text{ cm} \\ \text{Length of chord AB} &= 2BT \\ &= 2 \times 12 \\ &= 24 \text{ cm}\end{aligned}$$

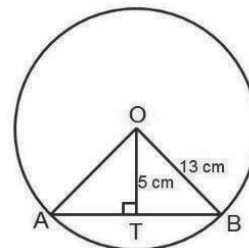

3. Find out the length of the chord, which is at a distance of 7 cm from the centre of a circle, whose radius is 25 cm.

Solution:

$$\begin{aligned}\text{Radius} &= 25 \text{ cm} \\ \text{From } \triangle OBR \\ OB^2 &= BR^2 + OR^2 \\ 25^2 &= BR^2 + 7^2 \\ 625 &= BR^2 + 49 \\ 625 - 49 &= BR^2 \\ 576 &= BR^2 \\ BR &= 24 \text{ cm} \\ \text{Length of chord PB} &= 2BR \\ \text{Length of chord PB} &= 2 \times 24 \text{ cm} \\ \text{Length of chord PB} &= 48 \text{ cm}\end{aligned}$$

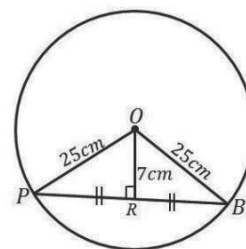

Practice

1. A chord of length 30 cm is 8 cm away from the centre of the circle. What is the radius of the circle?
2. A chord in a circle is 16 cm long and its perpendicular distance from the centre is 6 cm. What is the radius of the circle?
3. A circle has a radius of 1.3 cm. A chord is of length 2.4 cm. Find the distance of this chord from the centre.
4. Find the length of the chord, which is at a distance of 17 cm from the centre of a circle, whose radius is 23 cm.

Lesson Title: Applications of Circle Theorem 1	Theme: Geometry
Lesson Number: PHM3-L018	Class: SSS 3
 Learning Outcome By the end of the lesson, you will be able to solve problems using Circle Theorem 1.	

Overview

The focus of this lesson is to solve problems using Circle Theorem 1.

This theorem states that a straight line from the centre of a circle that bisects a chord is at right angles to the chord.

Solved Examples

1. In the circle with centre O, $OM \perp PQ$, $OM = 4$ cm and $PQ = 10$ cm. Find x to 1 decimal place.

Solution:

$$\begin{aligned}
 |PQ| &= 10 \text{ cm} \\
 |MP| &= 5 \text{ cm} && \perp \text{ from centre bisects chord} \\
 |OP|^2 &= |OM|^2 && \text{Pythagoras Theorem} \\
 &+ |MP|^2 \\
 &= 4^2 + 5^2 && \text{substitute } |OM| = 4 \text{ cm, } |PM| = 5 \text{ cm} \\
 &= 25 + 16 \\
 |OP| &= \sqrt{41} \\
 &= 6.403 \\
 |OP| &= 6.4 \text{ cm} \\
 &x \text{ is } 6.4 \text{ cm to } 1 \text{ d.p.}
 \end{aligned}$$

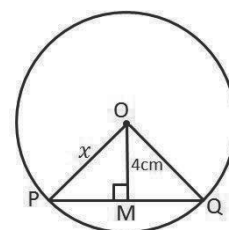

2. In a circle of radius 19 cm, calculate the length of a chord which is 10 cm from the centre.

Solution:

$$\begin{aligned}
 &\text{From } \triangle AOK \\
 AO^2 &= AK^2 + OK^2 && \text{Pythagoras theorem} \\
 19^2 &= AK^2 + 10^2 \\
 361 &= AK^2 + 100 \\
 361 - 100 &= AK^2 \\
 261 &= AK^2 \\
 AK &= \sqrt{261} \\
 AK &= 16.16 \\
 \text{Length of chord}(AB) &= 2AK \\
 &= 2 \times 16.16 \\
 &= 32.32 \text{ cm}
 \end{aligned}$$

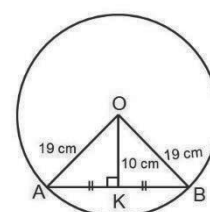

3. Find the distance of a chord of length 20 cm from the centre of a circle of radius 14 cm.

Solution:

From ΔXOT

$$OX^2 = XT^2 + OT^2 \quad \text{Pythagoras theorem}$$

$$14^2 = 10^2 + d^2$$

$$196 = 100 + d^2$$

$$196 - 100 = d^2$$

$$96 = d^2$$

$$d = \sqrt{96}$$

$$d = 9.8 \text{ cm}$$

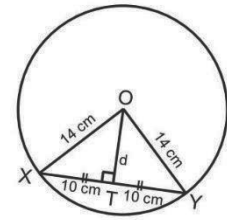

4. Find the radius of a circle, if a chord of 24 cm long is 5 cm distant from the centre.

Solution:

From ΔPOR

$$PO^2 = PR^2 + OR^2 \quad \text{Pythagoras theorem}$$

$$PO^2 = 12^2 + 5^2$$

$$PO^2 = 144 + 25$$

$$PO^2 = 169$$

$$PO = \sqrt{169}$$

$$PO = 13$$

$$\text{radius} = 13 \text{ cm}$$

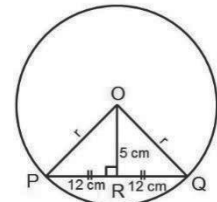

Practice

1. A chord of a circle is 18 cm. Calculate the radius of the circle if the chord is 7 cm from the centre of the circle. Give your answer to 2 decimal places.
2. In the circle with centre O, $OX \perp AB$, $OX = 8 \text{ cm}$ and $OA = 10 \text{ cm}$. Find AB .
3. Calculate the length of a chord of a circle with a radius of 25 cm if the chord is 24 cm from the centre of circle.
4. Find the distance of a chord with a length of 23 cm from the centre of a circle of radius 18 cm. Give your answer to 3 significant figures.

Lesson Title: Circle Theorem 2	Theme: Geometry
Lesson Number: PHM3-L019	Class: SSS 3
 Learning Outcome By the end of the lesson, you will be able to identify and demonstrate the angle subtended at the centre of a circle is twice that subtended at the circumference.	

Overview

The second theorem deals with angles at the centre and at the circumference of a circle.

Circle Theorem 2

The angle subtended at the centre of a circle is twice that subtended at the circumference.

For each of the circles below:

- Arc AB subtends $\angle AOB$ at the centre of the circle.
- Depending on the position of point P on the circle, we can have 3 different ways of how $\angle APB$ is formed at the circumference of the circle.
- The 3 ways are shown on the circles on the board.

Given: Circle with centre O, arc AB subtending $\angle AOB$ at the centre of the circle, and $\angle APB$ at the circumference.

To prove: $\angle AOB = 2 \times \angle APB$

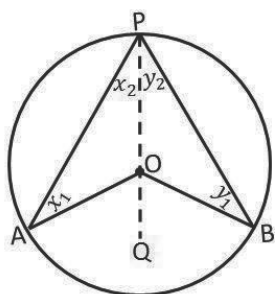

Figure a.

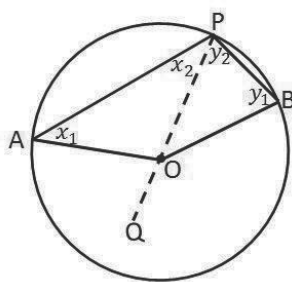

Figure b.

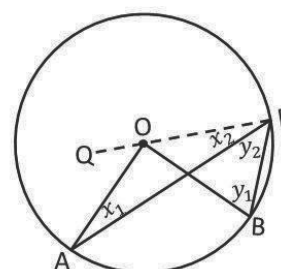

Figure c.

Proof

	$ OA = OP $	equal radii
	$x_1 = x_2$	equal base angles of isosceles Δ
	$\angle AOQ = x_1 + x_2$	exterior $\angle =$ sum of interior opposite \angle s
	$\angle AOQ = 2x_2$	$(x_1 = x_2)$
Similarly,	$\angle BOQ = 2y_2$	
In Figure a.	$\angle AOB = \angle AOQ + \angle BOQ$	
In Figure b.	reflex $\angle AOB = 2x_2 + 2y_2$	

$$\begin{aligned}
 &= 2(x_2 + y_2) \\
 &= 2 \times \angle APB \\
 \text{In Figure c.} \quad \angle AOB &= \angle BOQ \\
 &= - \angle AOQ \\
 &= 2y_2 - 2x_2 \\
 &= 2(y_2 - x_2) \\
 &= 2 \times \angle APB \\
 \text{In every case,} \quad \angle AOB &= 2 \times \angle APB
 \end{aligned}$$

- Use the statement **\angle at centre = $2\angle$ at circumference** when referring to this theorem in solving problems.

Solved Examples

- Find the value of the unknown angle b . Mark the angle subtended by the arc.

Solution:

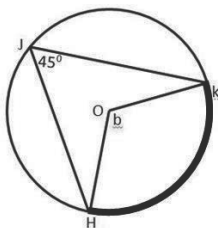

$$\begin{aligned}
 b &= 2 \times 45^\circ \\
 b &= 90^\circ
 \end{aligned}$$

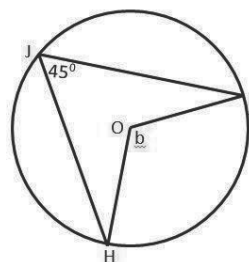

\angle at centre = $2\angle$ at circumference

- Find the value of $\angle x$ in each of the following diagrams:

Solution:

$$\begin{aligned}
 2 \times 69^\circ &= x & \angle \text{ at centre} &= 2\angle \text{ at circumference} \\
 138^\circ &= x \\
 x &= 138^\circ
 \end{aligned}$$

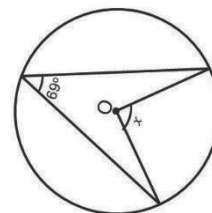

- Solution:**

$$\begin{aligned}
 2 \times x &= 146^\circ & \angle \text{ at centre} &= 2\angle \text{ at circumference} \\
 2x &= 146^\circ \\
 \frac{2x}{2} &= \frac{146^\circ}{2} \\
 x &= 73^\circ
 \end{aligned}$$

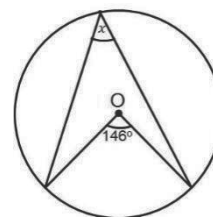

4. Find the values of e and f in the figure at right:

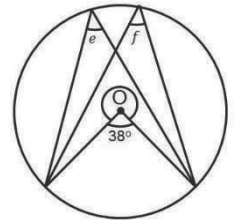

Solution:

$$\begin{aligned}
 2 \times e &= 38^\circ & \angle \text{ at centre} &= 2\angle \text{ at circumference} \\
 2e &= 38^\circ \\
 \frac{2e}{2} &= \frac{38^\circ}{2} \\
 e &= 19^\circ \\
 2 \times f &= 38^\circ & \angle \text{ at centre} &= 2\angle \text{ at circumference} \\
 2f &= 38^\circ \\
 \frac{2f}{2} &= \frac{38^\circ}{2} \\
 f &= 19^\circ
 \end{aligned}$$

Practice

1. Find the angles marked with letters in the following figures:

a.

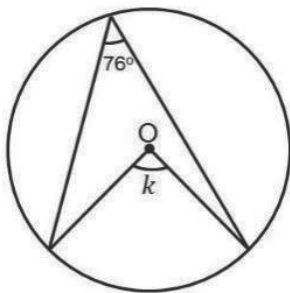

b.

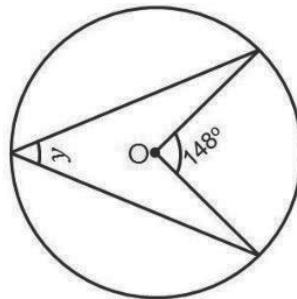

c.

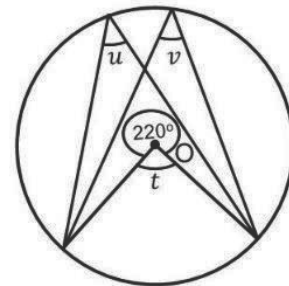

Lesson Title: Applications of Circle Theorem 2	Theme: Geometry
Lesson Number: PHM3-L020	Class: SSS 3
 Learning Outcome By the end of the lesson, you will be able to solve problems using Circle Theorem 2.	

Overview

The focus of this lesson is to solve problems with the second circle theorem. This theorem states that the angle subtended at the centre of a circle is twice that subtended at the circumference.

Solved Examples

1. Given O is the centre of the circle, find the unknown angles in the circle shown. Give reasons for your answer.

Solution:

Step 1. Assess and extract the given information from the problem.

$$\angle POR = 210^\circ$$

Step 2. Use theorems and the given information to find all equal angles and sides on the diagram.

$$a = \frac{1}{2} \times 210 \quad \angle \text{at centre} = 2\angle \text{at circumference}$$

$$a = 105^\circ$$

$$\begin{aligned} \text{reflex} \angle POR &= 360 - 210 && \text{sum of } \angle \text{s in a circle} = 360^\circ \\ &= 150^\circ \end{aligned}$$

Step 3. Solve for b .

$$b = \frac{1}{2} \times 150 \quad \angle \text{at centre} = 2\angle \text{at circumference}$$

$$b = 75^\circ$$

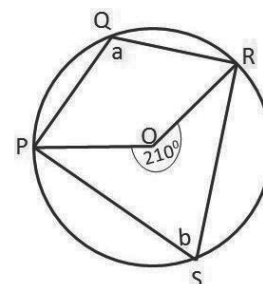

2. Find the values of a , b and c in the figure below.

Solution:

$$2 \times 87 = a \quad \angle \text{at centre} = 2 \times \angle \text{at circumference}$$

$$174 = a$$

$$a = 174^\circ$$

$$174 + b = 360^\circ \quad \text{Angles meeting at a point} = 360^\circ$$

$$b = 360 - 174$$

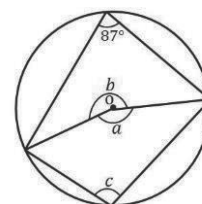

NOT TO SCALE

$$\begin{aligned}
 b &= 186^\circ \\
 2c &= b \\
 2c &= 186 \\
 \frac{2c}{2} &= \frac{186}{2} \\
 c &= 93^\circ
 \end{aligned}$$

3. Find the values of values of m, n, p and q in the figure given.

Solution:

$$m + 69 = 180 \quad \text{Adjacent angles on a straight line}$$

$$m = 180 - 69$$

$$m = 111^\circ$$

$$2 \times m = p \quad \angle \text{at centre} = 2 \times \angle \text{at circumference}$$

$$2 \times 111 = p$$

$$222 = p$$

$$p = 222^\circ$$

$$n + p = 360^\circ \quad \text{Angles meeting at a point } 360^\circ$$

$$n + 222 = 360$$

$$n = 360 - 222$$

$$n = 138^\circ$$

$$2 \times q = n \quad \angle \text{at centre} = 2 \angle \text{at circumference}$$

$$2q = 138^\circ$$

$$\frac{2q}{2} = \frac{138}{2}$$

$$q = 69^\circ$$

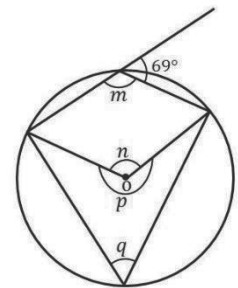

NOT TO SCALE

Practice

Find the angles marked with letters in the following figures.
[FIGURES ARE NOT DRAWN TO SCALE]

a.

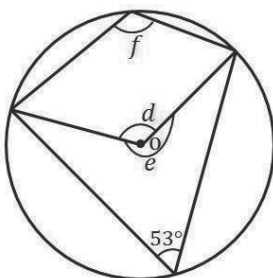

b.

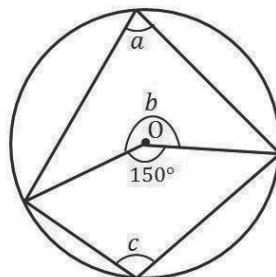

c.

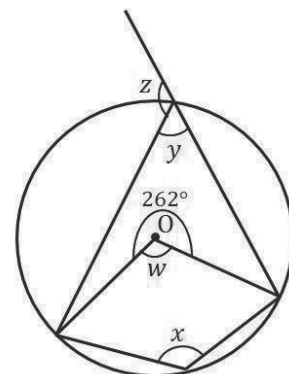

Lesson Title: Circle Theorems 3 and 4	Theme: Geometry
Lesson Number: PHM3-L021	Class: SSS 3
 Learning Outcomes By the end of the lesson, you will be able to identify and demonstrate: <ol style="list-style-type: none"> 1. The angle in a semi-circle is a right angle. 2. Angles in the same segment are equal. 	

Overview

- This lesson deals with 2 theorems.
- The first theorem in this lesson concerns the angle in a semi-circle.
- The second theorem deals with angles in the same segment.

Circle Theorem 3

The angle in a semi-circle is a right angle.

Given: Circle with centre O and diameter AB. X is any point on the circumference of the circle.

To prove: $\angle AXB = 90^\circ$

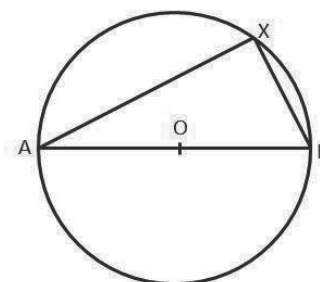

Proof (Circle Theorem 3)

$$\begin{aligned} \angle AOB &= 2\angle AXB && \angle \text{ at the centre} = 2\angle \text{ at the circumference} \\ \angle AOB &= 180^\circ && \angle \text{ straight line} = 180^\circ \\ 2\angle AXB &= 180^\circ \\ \angle AXB &= \frac{180^\circ}{2} \\ \angle AXB &= 90^\circ \end{aligned}$$

- This theorem shows that the angle of the diameter of a circle subtends a right angle at the circumference.
- Use the statement **\angle in semi-circle** when referring to this theorem in solving problems. This theorem is a special case of \angle at the centre = $2\angle$ at the circumference.

Circle Theorem 4

Angles in the same segment are equal.

Given: Circle with centre O with points P and Q on the circumference of the circle. Arc AB subtends $\angle APB$ and $\angle AQB$ in the same segment of the circle.

To prove: $\angle APB = \angle AQB$

Proof (Circle Theorem 4)

$$\angle AOB = 2x_1 \quad \angle \text{ at the centre} = 2\angle \text{ at the circumference}$$

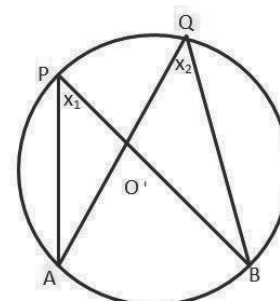

$$\begin{aligned}\angle AOB &= 2x_2 && \angle \text{ at the centre} = 2\angle \text{ at the circumference} \\ x_1 &= x_2 \\ \angle APB &= \angle AQB\end{aligned}$$

- Use the statement **∠s in same segment** when referring to this theorem in solving problems.

Solved Examples

1. P, Q and R are points on a circle, centre O. If $\angle RQO = 20^\circ$, what is the size of $\angle PRO$?

Solution:

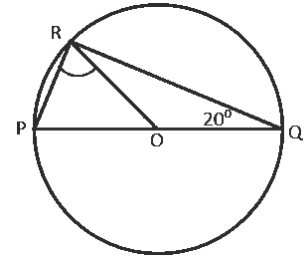

$$\begin{aligned}\angle QRO &= \angle RQO = 20^\circ && \text{base } \angle \text{s of isosceles } \Delta \\ \angle PRO &= \angle PRQ - \angle QRO \\ \angle PRO &= 90 - 20 && \angle \text{ in a semi-circle} \\ \angle PRO &= 70^\circ\end{aligned}$$

2. Find the unknown angle in the diagram.

Solution:

$$\begin{aligned}c &= 24^\circ && \angle \text{s in the same segment} \\ d &= 102 - 24 && \text{exterior } \angle \text{ of } \Delta = \\ &&& \text{sum of the interior opposite } \angle \text{s} \\ d &= 78^\circ\end{aligned}$$

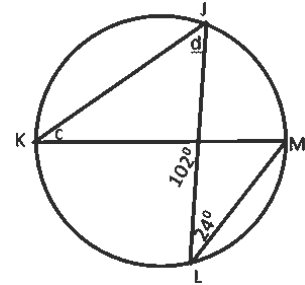

3. In the diagram below, O is the centre of the circle, $ISQI = IQRI$ and $\angle PQR = 68^\circ$. Calculate $\angle PRS$

Solution:

$$\begin{aligned}\angle QSR &= \angle QRS && \text{base } \angle \text{s of isosceles } \Delta \\ \angle QSR + \angle QRS + \angle PQR &= 180^\circ && \angle \text{s in a triangle} \\ 2 \times \angle QRS + 68^\circ &= 180^\circ \\ 2\angle QRS &= 180^\circ - 68^\circ \\ 2\angle QRS &= 112^\circ \\ \angle QRS &= \frac{112^\circ}{2} \\ \angle QRS &= 56^\circ \\ \angle PRS + 56^\circ &= 90^\circ && \angle \text{ in a semi-circle} \\ \angle PRS &= 90^\circ - 56^\circ \\ \angle PRS &= 34^\circ\end{aligned}$$

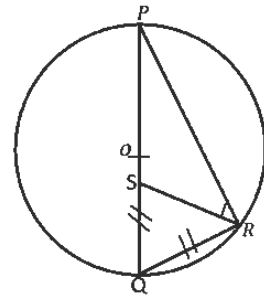

Practice

1. Find the angles marked with letters in the following diagrams. In each case, O is the centre of the circle.

a.

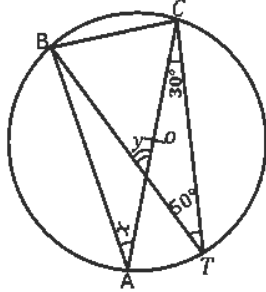

b.

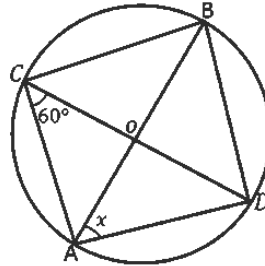

c.

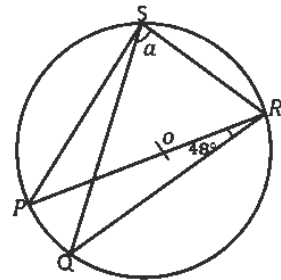

2. In the diagram below, O is the centre of the circle, QOR is a diameter and $\angle PSR$ is 37° . Find $\angle PRQ$.

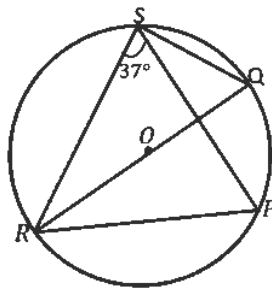

Lesson Title: Applications of Circle Theorems 3 and 4	Theme: Geometry
Lesson Number: PHM3-L022	Class: SSS 3
 Learning Outcome By the end of the lesson, you will be able to solve problems using Circle Theorems 3 and 4.	

Overview

During this lesson, we will solve problems using the theorem that angles in a semi-circle are a right angle. We will also use the theorem that angles in the same segment are equal when solving problems.

Solved Examples

1. Given O is the centre of the circle, find the unknown angle in the circle shown.

Solution:

Step 1. Assess and extract the given information from the problem.

$$\text{Given angle} = 65^\circ$$

Step 2. Use theorems and the given information to find all equal angles and sides on the diagram.

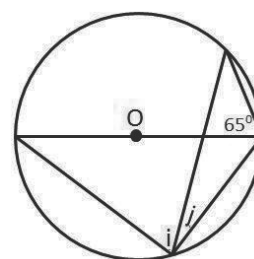

$$i = 65^\circ \quad \angle\text{s in the same segment}$$

$$i + j = 90 \quad \angle \text{ in a semi-circle}$$

$$65 + j = 90$$

Step 3. Solve for j .

$$j = 90 - 65$$

$$j = 25^\circ$$

2. AB is the diameter of a circle, with centre O. If $\angle DEB = 70^\circ$, find $\angle DBC$ and $\angle DAC$

Solution:

$$\angle BDE = 90^\circ \quad \angle \text{ in a semi-circle}$$

$$\angle DEB + \angle BDE + \angle DBE = 180^\circ \quad \angle\text{s in a triangle}$$

$$70^\circ + 90^\circ + \angle DBE = 180^\circ$$

$$160^\circ + \angle DBE = 180^\circ$$

$$\angle DBE = 180^\circ - 160^\circ$$

$$\angle DBE = 20^\circ$$

$$\angle DAC = \angle DBE \quad \angle\text{s in the same segment}$$

$$\angle DAC = 20^\circ$$

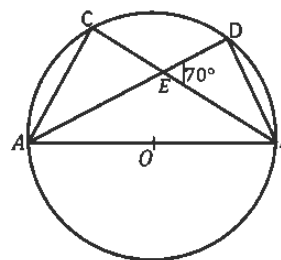

3. Find the angles marked with letters in the following diagrams.

Solutions:

a.

$$\begin{aligned}
 a &= 35^\circ && \angle\text{s in the same segment} \\
 b &= 75^\circ && \angle\text{s in the same segment} \\
 b + 35^\circ + c &= 180^\circ && \text{sum of interior } \angle\text{s of a } \Delta \\
 75^\circ + 35^\circ + c &= 180^\circ \\
 110^\circ + c &= 180^\circ \\
 c &= 180^\circ - 110^\circ \\
 c &= 70^\circ
 \end{aligned}$$

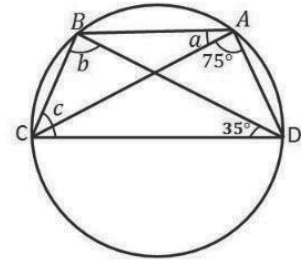

b.

$$\begin{aligned}
 q &= 36^\circ && \angle\text{s in the same segment} \\
 r + 36^\circ + 80^\circ &= 180^\circ && \text{Opposite } \angle\text{s of a quadrilateral} \\
 r + 116^\circ &= 180^\circ \\
 r + 116^\circ &= 180^\circ \\
 r &= 180^\circ - 116^\circ \\
 r &= 64^\circ \\
 p &= r && \angle\text{s in the same segment} \\
 p &= 64^\circ
 \end{aligned}$$

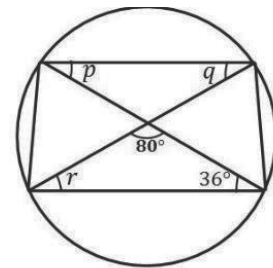

Practice

Find the angles marked with letters in the following diagrams.

a.

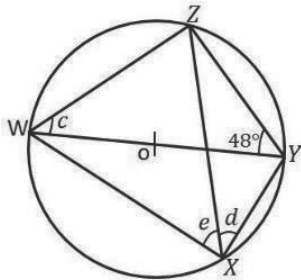

b.

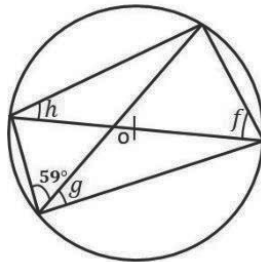

c.

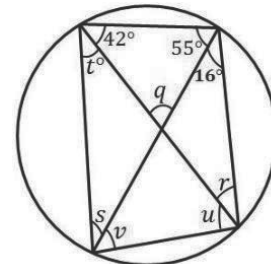

Lesson Title: Circle Theorem 5	Theme: Geometry
Lesson Number: PHM3-L023	Class: SSS 3
 Learning Outcome By the end of the lesson, you will be able to identify and demonstrate that opposite angles of a cyclic quadrilateral are supplementary.	

Overview

This theorem deals with angles in a cyclic quadrilateral. In a cyclic quadrilateral, all 4 vertices lie on the circumference of the circle.

Circle Theorem 5

Given: Cyclic quadrilateral $ABCD$, with A, B, C and D on the circumference of the circle.

To prove: $\angle BAD + \angle BCD = 180^\circ$

Proof:

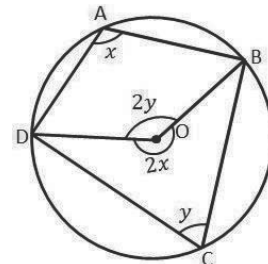

$$\begin{aligned}\angle BOD &= 2y \\ \text{reflex } \angle BOD &= 2x \\ \therefore 2x + 2y &= 360^\circ \\ \therefore x + y &= 180^\circ\end{aligned}$$

\angle at the centre = $2\angle$ at the circumference
 \angle at the centre = $2\angle$ at the circumference
 \angle s at a point

$$\angle BAD + \angle BCD = 180^\circ$$

$$\text{Similarly, } \angle ABC + \angle ADC = 180^\circ$$

- Use the statement **opposite \angle s of a cyclic quadrilateral** when referring to this theorem in solving problems.

It follows from this theorem that the exterior angle of a cyclic quadrilateral is equal to the opposite interior angle.

- Use the statement **exterior cyclic quadrilateral = opposite interior angle** when using this theorem to solve problems.

Solved Examples

- Find the unknown angle in the circle shown. Give reasons for your answer.

Solution:

Step 1. Assess and extract the given information from the problem.

$$\text{given } \angle WXY = 106^\circ, \angle XYZ = 87^\circ$$

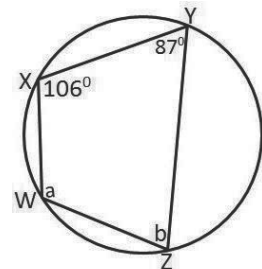

Step 2. Use theorems and the given information to find all equal angles on the diagram.

Step 3. Solve for a and b .

$$\begin{aligned} a + 87 &= 180 && \text{opposite } \angle\text{s of a cyclic quadrilateral} \\ a &= 180 - 87 \\ a &= 93^\circ \\ b + 106 &= 180 && \text{opposite } \angle\text{s of a cyclic quadrilateral} \\ b &= 180 - 106 \\ b &= 74^\circ \end{aligned}$$

2. Find the unknown angle in the circle shown. Give reasons for your answer.

Solution:

$$\text{Given angle} = 114^\circ$$

$$a = \angle HIJ \quad \angle \text{exterior cyclic quadrilateral} = \text{opposite interior angle}$$

$$a = 114^\circ$$

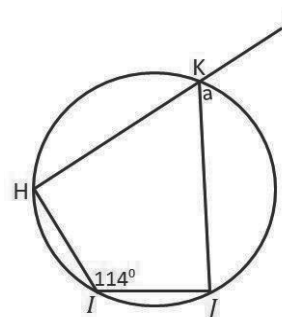

3. Find the angles marked with letters in the following diagrams.

Solutions:

a.

$$x + 100^\circ = 180^\circ \quad \text{opposite } \angle\text{s of a cyclic quadrilateral}$$

$$x = 180^\circ - 100^\circ$$

$$x = 80^\circ$$

$$y + 110^\circ = 180^\circ \quad \text{opposite } \angle\text{s of a cyclic quadrilateral}$$

$$y = 180^\circ - 110^\circ$$

$$y = 70^\circ$$

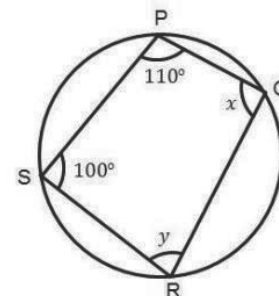

b.

$$a + 70^\circ = 180^\circ \quad \text{opposite } \angle\text{s of a cyclic quadrilateral}$$

$$a = 180^\circ - 70^\circ$$

$$a = 110^\circ$$

$$b + 115^\circ = 180^\circ \quad \text{opposite } \angle\text{s of a cyclic quadrilateral}$$

$$b = 180^\circ - 115^\circ$$

$$b = 65^\circ$$

$$c = b \quad \text{exterior } \angle = \text{opposite interior } \angle \text{ of a cyclic quadrilateral}$$

$$c = 65^\circ$$

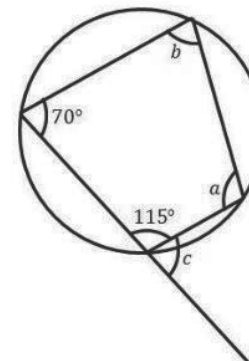

Practice

1. Find the angles marked with letters in the following diagrams.

a.

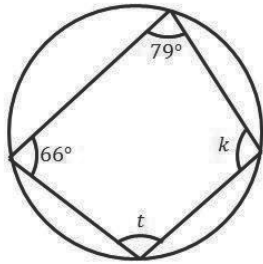

b.

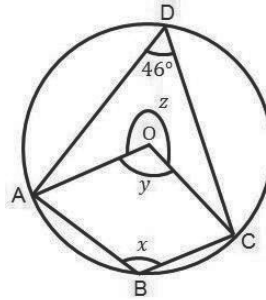

c.

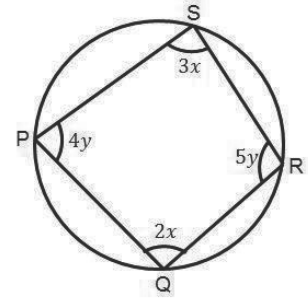

Lesson Title: Applications of Circle Theorem 5	Theme: Geometry
Lesson Number: PHM3-L024	Class: SSS 3
 Learning Outcome By the end of the lesson, you should be able to solve problems using Circle Theorem 5.	

Overview

In this lesson, we will be solving problems on the theorem which states that opposite angles of a cyclic quadrilateral are supplementary, that is they add up to 180° .

By now, we have learned enough circle theorems to be able to use more than one of them in solving problems.

Solved Examples

1. Given O is the centre of the circle, find the unknown angle in the circle below:

Solution:

Step 1. Assess and extract the given information from the problem.

given $\angle ROP = 102^\circ$

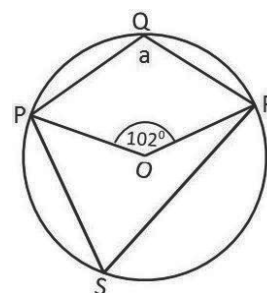

- We are required to find $\angle RQP$.
- We can see from the diagram that we have an angle at the centre and 2 angles of interest at the circumference.
- If either of the angles at the circumference is subtended by the same arc as the angle at the centre, this should lead us to the theorem:
 \angle at the centre = $2\angle$ at circumference
- We also have a cyclic quadrilateral $PQRS$ that may be of use in finding the missing angle because opposite \angle s of a cyclic quadrilateral = 180° .

Step 2. Use theorems and the given information to find all equal angles on the diagram.

$$\angle RSP = \frac{1}{2} \times 102 \quad \angle \text{ at the centre} = 2\angle \text{ at the circumference}$$

$$\angle RSP = 51^\circ$$

$$\angle RQP + 51 = 180$$

opposite \angle s of a cyclic quadrilateral

Step 3. Solve for $\angle RQP$.

$$\angle RQP = 180 - 51$$

$$\angle RQP = 129^\circ$$

2. The diagram below shows a circle PQRS in which $\angle PRQ=54^\circ$ and $\angle SPQ=97^\circ$,

Find $\angle PQS$

Solution:

$$\angle PRS + \angle PRQ + \angle SPQ = 180^\circ \quad \text{opposite } \angle\text{s of a cyclic quadrilateral}$$

$$\angle PRS + 54^\circ + 97^\circ = 180^\circ$$

$$\angle PRS + 151^\circ = 180^\circ$$

$$\angle PRS = 180^\circ - 151^\circ$$

$$\angle PRS = 29^\circ$$

$$\angle PQS = \angle PRS \quad \angle\text{s in the same segment}$$

$$\angle PQS = 29^\circ$$

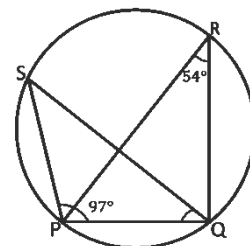

Join S to R (chord SR shown)

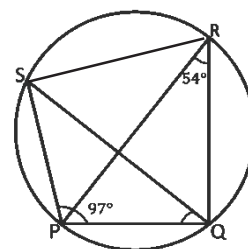

3. Find the angles marked with letters in the following diagrams.

Solutions:

a.

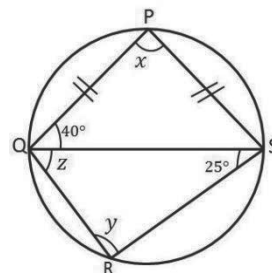

$$\angle PQS = \angle PSQ \quad \text{Base } \angle\text{s of isosceles } \Delta$$

$$\angle PSQ = 40^\circ$$

$$\angle PQS + \angle PSQ + \angle QPS = 180^\circ \quad \text{sum of interior } \angle\text{s of a } \Delta$$

$$40^\circ + 40^\circ + x = 180^\circ \quad \text{opposite } \angle\text{s of a cyclic quadrilateral}$$

$$80^\circ + x = 180^\circ$$

$$x = 180^\circ - 80^\circ$$

$$x = 100^\circ$$

$$x + y = 180^\circ \quad \text{opposite } \angle\text{s of a cyclic quadrilateral}$$

$$100^\circ + y = 180^\circ$$

$$y = 180^\circ - 100^\circ$$

$$y = 80^\circ$$

$$\begin{aligned}
 z + y + 25^\circ &= 180^\circ && \text{sum of interior } \angle\text{s of a } \triangle \\
 z + 80^\circ + 25^\circ &= 180^\circ \\
 z + 105^\circ &= 180^\circ \\
 z &= 180^\circ - 105^\circ \\
 z &= 75^\circ
 \end{aligned}$$

b.

$$\begin{aligned}
 2 \times e &= 236^\circ && 2 \times \angle \text{ at circumference} \\
 &&& = \angle \text{ at the centre} \\
 \frac{2 \times e}{2} &= \frac{236^\circ}{2} \\
 e &= 118^\circ \\
 f + 236^\circ &= 360^\circ && \angle\text{s meeting at a point} \\
 f &= 360^\circ - 236^\circ \\
 f &= 124^\circ \\
 e + g &= 180^\circ && \text{opposite } \angle\text{s of a cyclic} \\
 &&& \text{quadrilateral} \\
 118^\circ + g &= 180^\circ \\
 g &= 180^\circ - 118^\circ \\
 g &= 62^\circ \\
 h &= e && \text{exterior } \angle = \text{opposite} \\
 &&& \text{interior } \angle \\
 h &= 118^\circ
 \end{aligned}$$

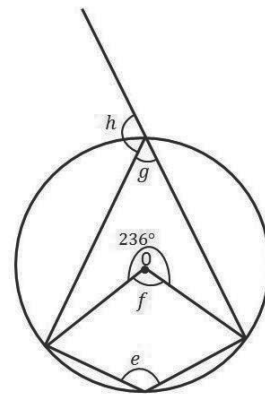

Practice

1. Find the angles marked with letters in the following diagrams.

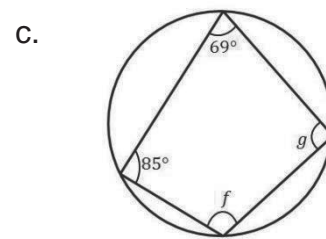
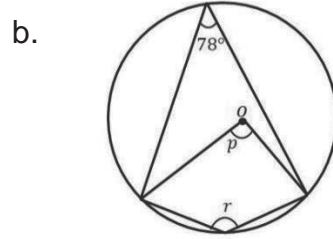
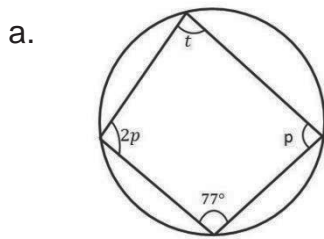

Lesson Title: Circle Theorems 6 and 7	Theme: Geometry
Lesson Number: PHM3-L025	Class: SSS 3
 Learning Outcomes By the end of the lesson, you will be able to identify and draw a tangent to a circle, and identify and demonstrate: <ol style="list-style-type: none"> 1. The angle between a tangent and a radius in a circle is equal to 90°. 2. The lengths of the two tangents from a point to a circle are equal. 	

Overview

This lesson deals with the theorems concerning tangents to a circle.

A tangent is a line which touches a circle at one point without cutting across the circle. It makes contact with a circle at only one point on the circumference. The line MN shown right is a tangent to the circle with centre O. It touches the circle at point T.

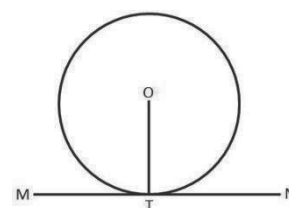

Circle Theorem 6

The angle between a tangent and a radius is equal to 90° .

Given: Circle with centre O, line l is a tangent to the circle at A.

To prove: $OA \perp l$

Proof:

We know, by definition, that the tangent to the circle touches the circle at one point only. No other points on the tangent touch the circle.

$$\begin{aligned}
 |OP| &> |OR| && |OR| = \text{radius of circle} \\
 \Rightarrow |OP| &> |OA| && \text{since } |OR| = |OA| \\
 \Rightarrow |OA| &< |OP|
 \end{aligned}$$

\Rightarrow OA is the shortest line from O to a point on the tangent.

The shortest line from the centre of a circle to a tangent is a perpendicular line.

$$\therefore OA \perp l \quad \text{radius} \perp \text{tangent}$$

- Use the statement “**radius \perp tangent**” whenever this theorem is used in solving problems.

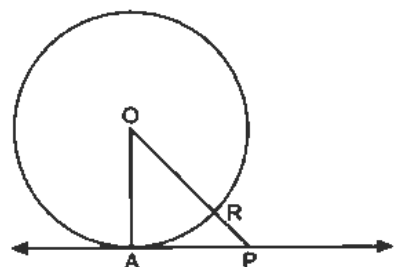

Circle Theorem 7

The lengths of the two tangents from a point to a circle are equal.

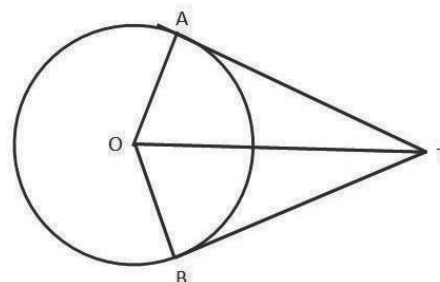

Given: A point T outside a circle with centre O. TA and TB are tangents to the circle at A and B respectively.

To prove: $|TA| = |TB|$

Proof:

$\angle OAT = \angle OBT = 90^\circ$	radius \perp tangent
$ OA = OB $	equal radii
$ OT = OT $	common side
$\therefore \triangle OAT = \triangle OBT$	RHS
$\therefore TA = TB $	equal tangents from same point

- Use the statement “equal tangents from same point” when referring to this theorem when solving problems.

Since $\angle AOT = \angle BOT$ and $\angle ATO = \angle BTO$, it also means that line TO bisects the angles at O and T. TO is therefore the line of symmetry for the diagram.

Solved Examples

- Find the missing angle in the given circle with centre O.

Solution:

Step 1. Assess and extract the given information from the problem.

Given angle = 65°

Step 2. Use theorems and the given information to find all equal angles on the diagram.

$$\begin{aligned} \angle PTO &= 90^\circ \\ a &= \angle TPO \\ a + 65 + 90 &= 180 \\ a &= 180 - 65 - 90 \end{aligned}$$

Step 3. Solve for a

$$a = 25^\circ$$

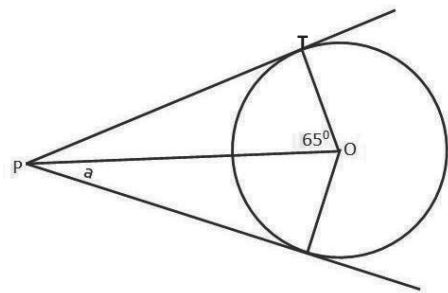

radius \perp tangent
symmetry (equal tangents)
 \angle s in a triangle

- In the figure at right, a line drawn through T is a tangent and O is the centre of the circle. Find the lettered angles.

Solution:

$$\begin{aligned} i &= 90^\circ && \angle \text{ in a semicircle} \\ i + j + 56^\circ &= 180^\circ && \text{sum of interior } \angle \text{ s in a } \triangle \\ 90^\circ + j + 56^\circ &= 180^\circ \\ 146^\circ + j &= 180^\circ \end{aligned}$$

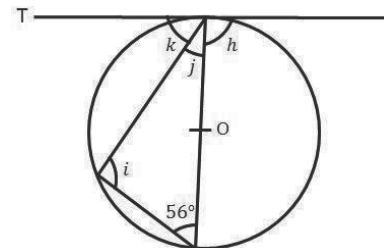

$$j = 180^\circ - 146^\circ$$

$$j = 34^\circ$$

$$h = 90^\circ \text{ radius } \perp \text{ tangent}$$

$$k + j = 90^\circ \text{ radius } \perp \text{ tangent}$$

$$k + 34^\circ = 90^\circ$$

$$k = 90^\circ - 34^\circ$$

$$k = 56^\circ$$

Practice

1. In the diagram at right, tangents PA and PB to a circle with centre O are drawn from a point P outside the circle. If the radius of the circle is 5cm, and OP=13cm, find PA and PB.

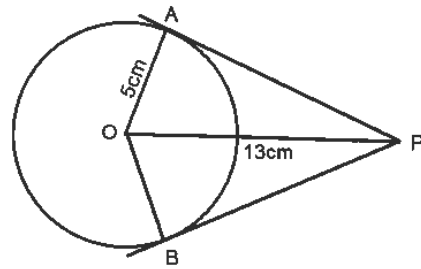

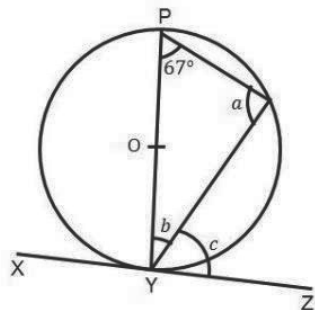

2. Find the angles marked with letters in the following diagrams. In each case, O is the centre of the circle.

a.

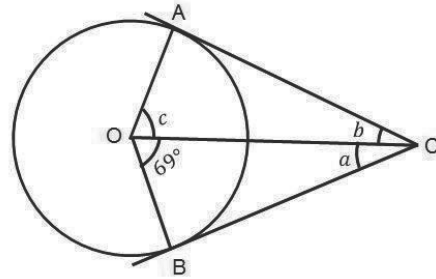

b.



Lesson Title: Applications of Circle Theorems 6 and 7	Theme: Geometry
Lesson Number: PHM3-L026	Class: SSS 3
 Learning Outcome By the end of the lesson, you will be able to solve problems using Circle Theorems 6 and 7.	

Overview

This lesson focuses on using the tangent theorems to solve problems.

Solved Examples

1. Find the missing angle in the given circle with centre O.

Solution:

Step 1. Assess and extract the given information from the problem.

given $\angle ADO = 36^\circ$, $DA \perp OA$; $\triangle OAD$ is a right-angled triangle

Step 2. Use theorems and the given information to find all equal angles on the diagram.

$$\begin{aligned}
 \angle OAD &= 90^\circ && \text{radius } \perp \text{ tangent} \\
 \angle AOD + 36 + 90 &= 180 && \text{ } \angle \text{s in a triangle} \\
 \angle AOD &= 180 - 36 - 90 \\
 &= 54
 \end{aligned}$$

Step 3. Solve for $\angle ABC$

$$\begin{aligned}
 \angle ABC &= \frac{1}{2} \times 54^\circ && \angle \text{ at the centre} = 2 \angle \\
 \angle ABC &= 27^\circ && \text{ at circumference}
 \end{aligned}$$

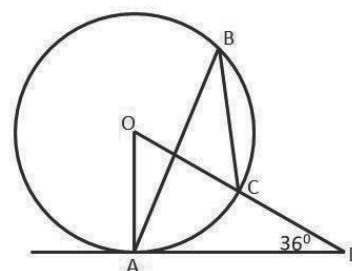

2. Find the unknown letter in the given circle with centre O.

Solution:

$$\begin{aligned}
 |LM| &= 6 \text{ cm}, |OK| = 2 \text{ cm} |LN| = 7.5 \text{ cm} && \text{given} \\
 |LM| &= |LK| && \text{equal tangents from the same point} \\
 |MN| &= |LN| - |LM| \\
 &= 7.5 - 6 \\
 |MN| &= 1.5 \text{ cm} \\
 |OM| &= 2 \text{ cm} && \text{equal radii}
 \end{aligned}$$

From $\triangle OMN$:

$$\begin{aligned}
 e^2 &= |OM|^2 + |MN|^2 && \text{Pythagoras theorem} \\
 e^2 &= 2^2 + 1.5^2 \\
 &= 4 + 2.25 \\
 e^2 &= 6.25 \\
 e &= \sqrt{6.25}
 \end{aligned}$$

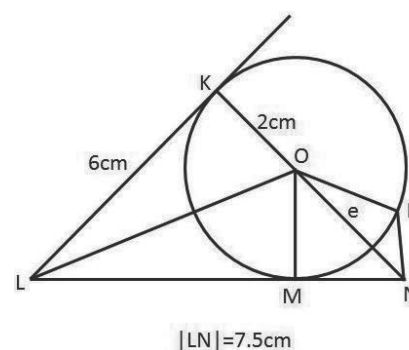

$$e = 2.5 \text{ cm}$$

3. The diagram below at right shows a belt QRST round a shaft R (of negligible radius) and a pulley of radius 1.2 m.

O is the centre of the pulley; $OR = 4 \text{ m}$ and the straight portions QR and RS of the belt are tangents at Q and S to the pulley.

Calculate:

a. Angle QOS, correct to the nearest degree.

lb. The length of the belt (QRST) to the nearest metre. [Use $\pi = 3.142$]

Solution:

a.

$$\text{Join O to R} = OR$$

$$\cos \angle SOR = \frac{1.2}{4}$$

$$\cos \angle SOR = 0.3$$

$$\angle SOR = \cos^{-1}(0.3)$$

$$= 72.54^\circ$$

$$\angle SOR = \angle QOR$$

$$\angle QOS = 2 \times \angle SOR$$

$$= 2 \times 72.54^\circ$$

$$= 145.08^\circ$$

$$= 145^\circ \text{ to the nearest degree}$$

From $\triangle SOR$

symmetry

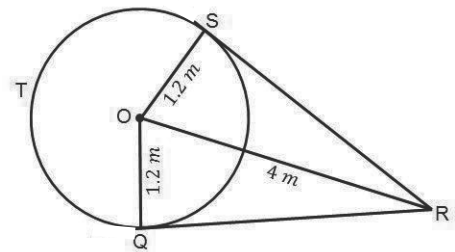

b.

$$SR = QR \quad \text{symmetry}$$

$$OR^2 = SR^2 + OS^2 \quad \text{Pythagoras' theorem}$$

$$4^2 = SR^2 + 1.2^2$$

$$16 = SR^2 + 1.44$$

$$16 - 1.44 = SR^2$$

$$SR^2 = 14.56$$

$$SR = \sqrt{14.56}$$

$$= 3.82 \text{ m}$$

$$\text{Length of STQ} = \frac{360^\circ - 145^\circ}{360^\circ} \times 2 \times 3.142 \times 1.2$$

$$= \frac{215^\circ}{360^\circ} \times 2 \times 3.142 \times 1.2$$

$$= \frac{1,621.272}{360}$$

$$= 4.50 \text{ m}$$

$$\text{Length of QRST} = \text{Length of QR} + \text{RS} + \text{STQ}$$

$$= 3.82 + 3.82 + 4.50$$

$$= 12.14$$

$$\text{Length of QRST} = 12 \text{ m to the nearest metre}$$

Practice

1. In the diagram below, tangents PA and PB to a circle with centre O are drawn from a point P outside the circle.

If $\angle AOB = 140^\circ$, and AB is joined, find $\angle APB$ and $\angle ABP$

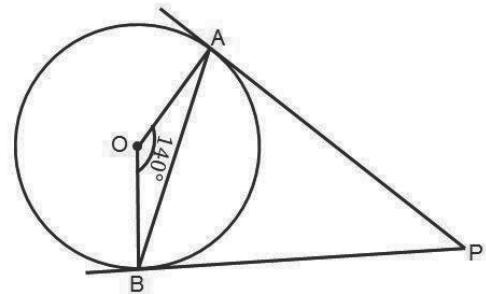

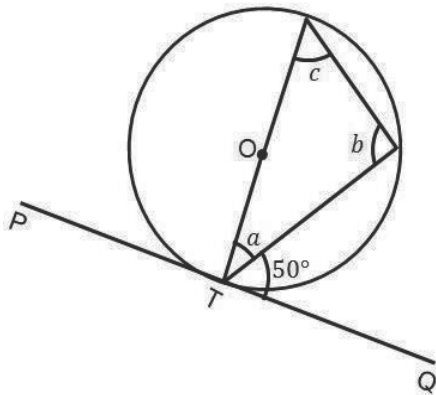

2. Find the angles marked with letters in the following diagrams. In each case, O is the centre of the circle.

a.

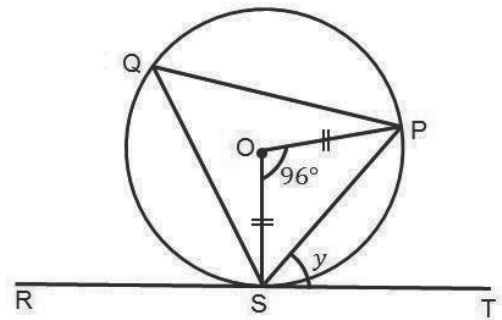

b.



Lesson Title: Circle Theorem 8 – Alternate segment theorem	Theme: Geometry
Practice Activity: PHM3-L027	Class: SSS 3
 Learning Outcome By the end of the lesson, you will be able to identify and demonstrate the alternate segment theorem.	

Overview

This is the final theorem on circles. The diagram shows that the chord AB divides the circle into 2 segments. The angle between a tangent to the circle and the chord drawn at the point of contact in one segment is the same as the angle subtended in the other segment by the chord.

Circle Theorem 7

The angle between a tangent to a circle and a chord drawn at the point of contact, is equal to the angle which the chord subtends in the alternate segment.

Given: Circle with centre O and tangent ST touching the circle at A. Chord PA subtends: $\angle APB$ and $\angle ADB$.

To prove:

- $\angle TAB = \angle APB$
- $\angle SAB = \angle AQB$

Proof:

$$\begin{aligned}
 x_1 + y &= 90^\circ \\
 \angle ABD &= 90^\circ \\
 \therefore x_2 + y &= 90^\circ \\
 \therefore x_1 &= x_2 = x_3 \\
 \therefore \angle TAB &= \angle APB \\
 \text{also } \angle SAB &= 180 - x_1 \\
 &= 180 - x_3 \\
 \angle SAB &= \angle AQB
 \end{aligned}$$

tangent \perp radius
 $\angle s$ in a semi – circle
 $\angle s$ in a triangle
 $\angle s$ in the same segment
 $\angle s$ on a straight line
 $x_1 = x_3$ proved
 Opposite $\angle s$ of a cyclic quadrilateral

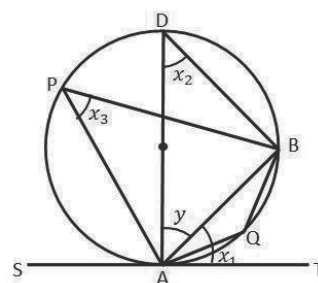

Use the statement $\angle s$ in alternate segment whenever this theorem is used in solving problems.

Solved Examples

1. Find the missing angles in the given circle.

Solution:

Step 1. Assess and extract the given information from the problem.

$$\angle PQR = 33^\circ \quad \text{given}$$

Step 2. Use theorems and the given information to find all equal angles on the diagram.

Step 3. Solve for a and b

i. $a = 33^\circ$ $\angle s$ in alternate segment

$$b = 33^\circ \quad \text{alternate angles, } OP \parallel SR$$

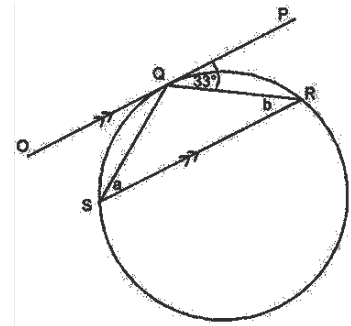

2. In the diagram below, PQ is the tangent to the circle RST at T. $|ST|=|SR|$ and $\angle RTQ=68^\circ$. Find $\angle PTS$

Solution:

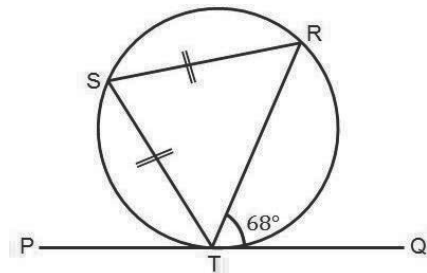

$$\begin{aligned} \angle RST &= 68^\circ && \angle s \text{ in alternate segment} \\ \angle STR &= \angle TRS && \text{Base } \angle s \text{ of isosceles } \Delta \\ \angle RST + \angle STR + \angle TRS &= 180^\circ && \text{Sum of } \angle s \text{ in a } \Delta \\ 68^\circ + 2\angle TRS &= 180^\circ \\ 2\angle TRS &= 180^\circ - 68^\circ \\ 2\angle TRS &= 112^\circ \\ \angle TRS &= \frac{112^\circ}{2} \\ \angle TRS &= 56^\circ \\ \angle PTS &= \angle TRS && \angle s \text{ in alternate} \\ \angle PTS &= 56^\circ \end{aligned}$$

3. In the diagram at right, O is the centre of the circle QRT, and PT is a tangent to the circle at T. Calculate the angle x .

Solution:

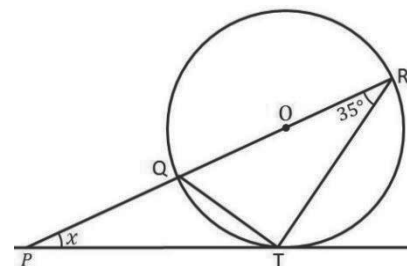

$$\begin{aligned} \angle QTR &= 90^\circ && \angle \text{ in a semi-circle} \\ \angle PQT &= \angle QTR + \angle QRT && \text{Exterior } \angle \text{ of } \Delta \end{aligned}$$

$$\begin{aligned} \angle PQT &= 90 + 35 \\ \angle PQT &= 125^\circ \\ \angle QTP &= 35^\circ && \angle s \text{ in alternate segment} \\ \angle PQT + \angle QTP &= 180^\circ \\ x + 125^\circ + 35^\circ &= 180^\circ \\ x + 160^\circ &= 180^\circ \\ x &= 180^\circ - 160^\circ \\ x &= 20^\circ \end{aligned}$$

Practice

1. In the diagram at right, PQT is a tangent to the circle QRS at Q. If $\angle QTR = 48^\circ$ and $\angle QRT = 95^\circ$, find $\angle QSR$.

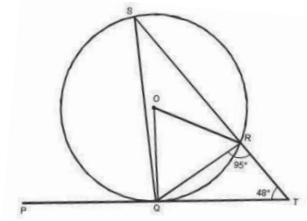

2. In the diagram at right, PQR is a tangent to the circle QST at Q. If $|QT| = |ST|$ and $\angle SQR = 72^\circ$, find $\angle PQT$.

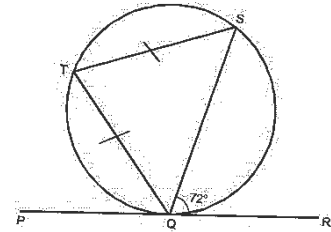

3. In the diagram at right, ABC is a tangent to the circle BDE at B. If $\angle DBE = 69^\circ$ and $\angle BDE = 58^\circ$, find $\angle DBC$.

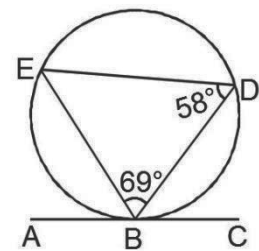

4. In the diagram at right, PQR is a tangent to the circle QST at Q. If $|QT| = |ST|$ and $\angle SQT = 64^\circ$, find $\angle SQR$.

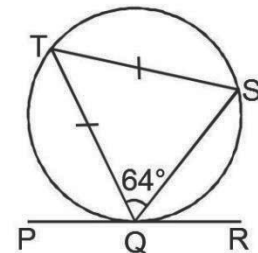

5. In the diagram below, PQR is a tangent to the circle QST at Q. If $|QT|=|ST|$ and $\angle QTS=40^\circ$, find $\angle TQR$.

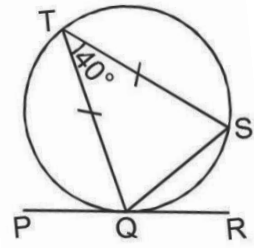

Lesson Title: Apply the alternate segment theorem	Theme: Geometry
Practice Activity: PHM3-L028	Class: SSS 3
 Learning Outcome By the end of the lesson, you will be able to solve problems using the alternate segment theorem.	

Overview

This lesson focuses on using the alternative segment theorem to solve problems.

Solved Examples

1. Find the missing angle in the given circle with centre O.

Solution:

Step 1. Assess and extract the given information from the problem.

Given $\angle RQT = 52^\circ$

Step 2. Use theorems and the given information to find all equal angles on the diagram.

Step 3. Solve for unknown angles.

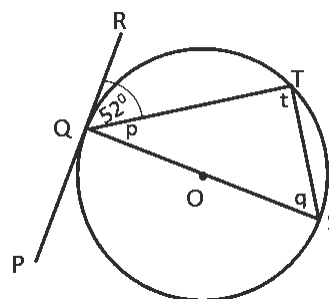

$$\begin{aligned}
 q &= 52^\circ && \angle s \text{ in alternate segment} \\
 \angle OTS = r &= 90^\circ && \angle \text{ in a semi-circle} \\
 p + 52^\circ &= 90^\circ && \text{radius} \perp \text{tangent} \\
 p &= 90^\circ - 52^\circ \\
 p &= 38^\circ
 \end{aligned}$$

2. In the diagram below, PQ is a tangent at T to the circle ABT. ABC is a straight line and TC bisects BTQ. Find x.

Solution:

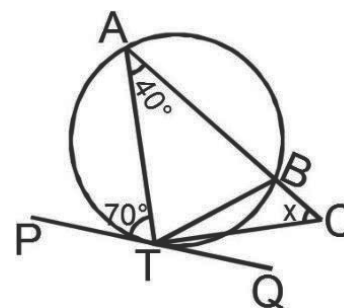

$$\begin{aligned}
 \angle ABT &= 70^\circ && \angle s \text{ in alternate segment} \\
 \angle ABT + \angle TBC &= 180^\circ && \text{Adjacent } \angle s \text{ on a straight line} \\
 70^\circ + \angle TBC &= 180^\circ \\
 \angle TBC &= 180^\circ - 70^\circ \\
 \angle TBC &= 110^\circ \\
 \angle BTQ &= 40^\circ && \angle s \text{ in alternate segment} \\
 \angle BTC &= \frac{\angle BTQ}{2} && \text{TC bisects } \angle BTQ
 \end{aligned}$$

$$\begin{aligned} \angle BCT + \angle BTC + \angle TBC &= 180^\circ && \text{sum of } \angle s \text{ in a } \Delta \\ X + 20^\circ + 110^\circ &= 180^\circ \\ X + 130^\circ &= 180^\circ \\ X &= 180^\circ - 130^\circ \\ X &= 50^\circ \end{aligned}$$

3. In the diagram, PR is a diameter of the circle with centre O. RS is a tangent at R and $\angle QPR = 58^\circ$. Find $\angle QRS$.

Solution:

$$\begin{aligned} \angle PQR &= 90^\circ && \angle \text{ in a semi-circle} \\ \angle PRS &= \angle PQR && \angle s \text{ in alternate segment} \\ \angle PRS &= 90^\circ \\ \angle PQR + \angle QPR + \angle PRQ &= 180^\circ && \text{sum of } \angle s \text{ in a } \Delta \\ 90 + 58 + \angle PRQ &= 180^\circ \\ \angle PRQ + 148 &= 180^\circ \\ \angle PRQ &= 180^\circ - 148^\circ \\ \angle PRQ &= 32^\circ \\ \angle QRS &= \angle PRQ + \angle PRS \\ \angle QRS &= 32^\circ + 90^\circ \\ \angle QRS &= 122^\circ \end{aligned}$$

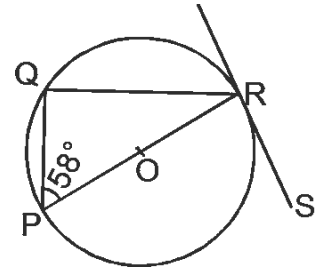

Practice

1. In the diagram at right, PQ is a tangent to the circle MTN at T. What is the size of $\angle MTN$?

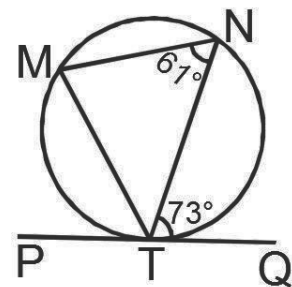

2. TR is the tangent to the circle PQR with centre O. Find the size of $\angle PRT$.

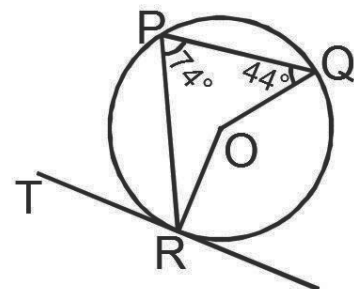

3. In the diagram below, PQR is a tangent to the circle SQT at Q. What is the size of $\angle SQT$?

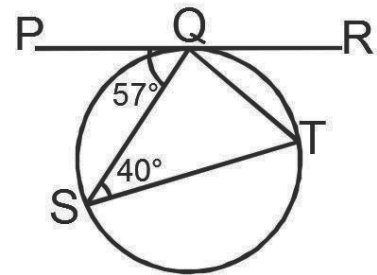

4. TR is the tangent to the circle PQR with centre O. Find the size of $\angle PQO$.

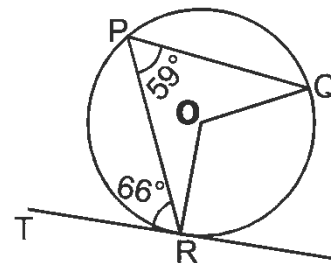

Lesson Title: Solving problems on circles	Theme: Geometry
Practice Activity: PHM3-L029	Class: SSS 3
 Learning Outcome By the end of the lesson, you will be able to apply circle theorems and other properties to find missing angles in various circle diagrams.	

Overview

This lesson brings together all 8 theorems. Now that we know all of the circle theorems, we need to be able to identify which ones we can apply to a particular problem.

Solved Examples

1. PQS is a circle with centre O. RST is a tangent at S and $\angle SOP = 96^\circ$. find $\angle PST$

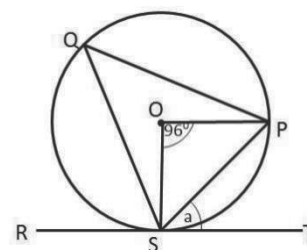

Solution:

The question can be solved in 2 ways using different circle theorems.

Step 1. Assess and extract the given information from the problem.

Given: RST is a tangent at S; $\angle SOP = 96^\circ$

Step 2. Use theorems and the given information to find all equal angles on the diagram.

Step 3. Write the answer.

Method 1.

$$\begin{aligned} \angle PST &= \angle SOP && \angle s \text{ in alternate segment} \\ \angle SOP &= \frac{1}{2} \times \angle SQP && \angle \text{ at the centre} = 2\angle \text{ at circumference} \\ \angle SOP &= \frac{1}{2} \times 96 \\ &= 48^\circ \\ \therefore \angle PST &= 48^\circ \end{aligned}$$

Method 2.

$$\begin{aligned} OS &= OP && \text{equal radii} \\ 2 \times \angle OSP + 96 &= 180 && \text{isosceles triangle} \\ \angle OSP &= \frac{180-96}{2} \\ &= 42^\circ \\ \angle OST &= 90^\circ && \text{radius} \perp \text{tangent} \\ \angle PST + 42 &= 90^\circ \\ \angle PST &= 90 - 42 \\ \angle PST &= 48^\circ \end{aligned}$$

2. In the diagram, TA is a tangent to the circle at A. If $\angle BCA = 40^\circ$ and $\angle DAT = 52^\circ$, Find $\angle BAD$

Solution:

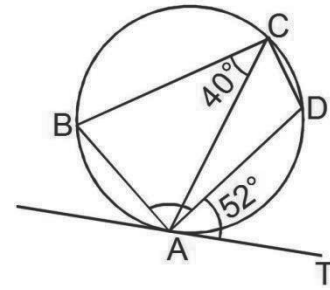

$$\begin{aligned} \angle ACD &= \angle DAT && \angle s \text{ in alternate segment} \\ \angle ACD &= 52^\circ \\ \angle BAD + \angle BCA + \angle ACD &= 180^\circ && \text{opposite } \angle s \text{ of a} \\ &&& \text{cyclic quadrilateral} \\ \angle BAD + 40^\circ + 52^\circ &= 180^\circ \\ \angle BAD + 92^\circ &= 180^\circ \\ \angle BAD &= 180^\circ - 92^\circ \\ \angle BAD &= 88^\circ \end{aligned}$$

Practice

1. In the diagram at right, TS is a tangent at S and $\angle SOP = 76^\circ$. Find $\angle PST$.

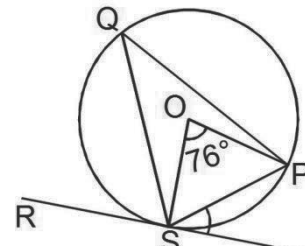

2. In the diagram at right, TS is a tangent to the circle at S, $\angle PQR = 117^\circ$ and $\angle PQR = 117^\circ$. Calculate $\angle PST$.

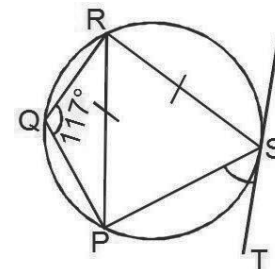

3. In the diagram at right, YW is a tangent to the circle at X, $\angle UVI = \angle VXI$ and $\angle VXW = 50^\circ$. Find the value of $\angle UXY$.

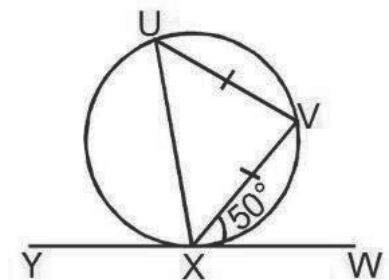

4. In the diagram at right, YW is a tangent to the circle at X , $|UV| = |VX|$ and $\angle UVX = 70^\circ$. Find the value of $\angle VXW$.

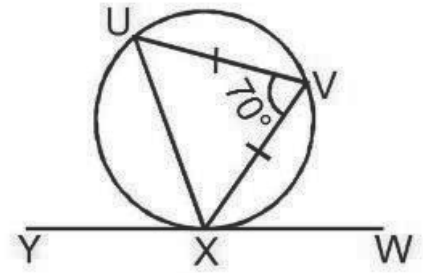

Lesson Title: Surface area of a cube	Theme: Mensuration
Lesson Number: PHM3-L030	Class: SSS 3
 Learning Outcome By the end of the lesson, you will be able to calculate the surface area of a cube using the appropriate formula.	

Overview

A cube is shown on the right. Below are **nets** of the cube.

A **net** is a two-dimensional flat shape that can be folded to make a three-dimensional object. There are 11 different nets of a cube.

The net of a solid shape like a cube, shows what a 3-dimensional shape looks like when it is opened flat into a 2-dimensional shape.

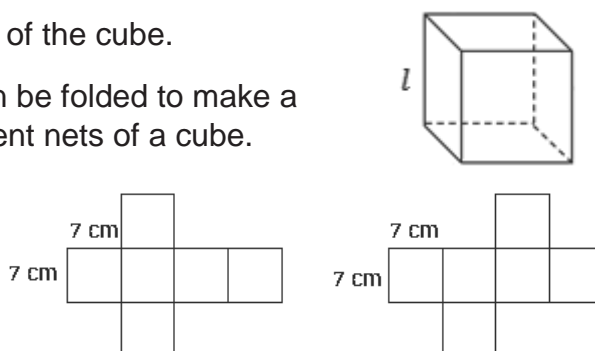

It can be used to find the **surface area** of the shape.

The surface area of a shape is the **sum of the areas** of the faces of the three-dimensional shape.

For a cube with 6 identical faces, each of area l^2 , the total surface area is:

$$A = 6 \times l^2 \text{ where } l \text{ is the length of one of the faces of the cube.}$$

Solved Examples

- Find the surface area of a cube of side length $l = 7.5$ cm.
Give your answer to 3 significant figures.

Solution:

Step 1. Assess and extract the given information from the problem.

Given: cube of side length = 7.5 cm

Step 2. Substitute into the appropriate formula.

$$\begin{aligned} \text{surface area} &= 6l^2 \\ &= 6 \times 7.5^2 \\ &= 6 \times 56.25 \\ &= 337.5 \end{aligned}$$

Step 3. Write the answer.

$$\text{surface area} = 338 \text{ cm}^2 \text{ to 3 s.f.}$$

- The sides of a cube are 5.4 cm long.
Find the surface area of the cube.

Solution:

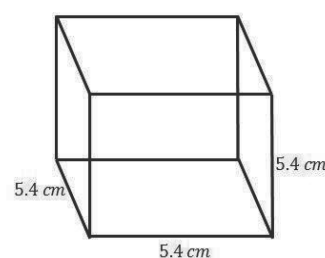
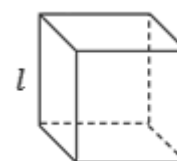

$$\begin{aligned}
 \text{Surface area} &= 6l^2 \\
 &= 6 \times 5.4^2 \\
 &= 174.96 \text{ cm}^2
 \end{aligned}$$

3. The sides of a cube are 7 cm long.
Find the surface area of the cube.

Solution:

$$\begin{aligned}
 \text{Surface area} &= 6l^2 \\
 &= 6 \times 7^2 \\
 &= 294 \text{ cm}^2
 \end{aligned}$$

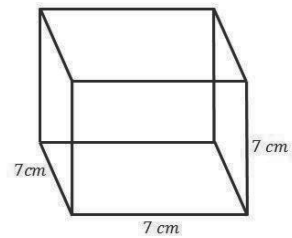

4. The total surface area of a cube is 150 cm^2 ; find a side of the cube.

Solution:

$$\begin{aligned}
 \text{Surface area} &= 6l^2 \\
 150 &= 6 \times l^2 \\
 6l^2 &= 150 \\
 \frac{6l^2}{6} &= \frac{150}{6} \\
 l^2 &= 25 \\
 l &= \sqrt{25} \\
 l &= 5 \text{ cm}
 \end{aligned}$$

5. The total surface area of a cube is $1,944 \text{ cm}^2$; find a side of the cube.

Solution:

$$\begin{aligned}
 \text{Surface area} &= 6l^2 \\
 1,944 &= 6 \times l^2 \\
 6l^2 &= 1,944 \\
 \frac{6l^2}{6} &= \frac{1,944}{6} \\
 l^2 &= 324 \\
 l &= \sqrt{324} \\
 l &= 18 \text{ cm}
 \end{aligned}$$

6. The edges of a cube are 17 cm long; find its total surface area.

Solution:

$$\begin{aligned}
 \text{Surface area} &= 6l^2 \\
 &= 6 \times 17^2 \\
 &= 1,734 \text{ cm}^2
 \end{aligned}$$

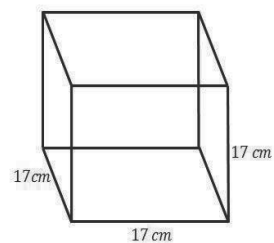

7. The total surface area of a cube is 600 cm^2 ; find a side of the cube.

Solution:

$$\begin{aligned} \text{Surface area} &= 6l^2 \\ 600 &= 6 \times l^2 \\ 6l^2 &= 600 \\ \frac{6l^2}{6} &= \frac{600}{6} \\ l^2 &= 100 \\ l &= \sqrt{100} \\ l &= 10 \text{ cm} \end{aligned}$$

Practice

- The sides of a cube are 8.5 cm long. Find the surface area of the cube. Give your answer to 3 significant figures.
- The edges of a cube are 9 cm long; find its total surface area.
- The total surface area of a cube is 96 cm^2 ; find a side of the cube.
- The total surface area of a cube is $1,014 \text{ cm}^2$; find a side of the cube.
- The sides of a cube are 13.5 cm long. Find the surface area of the cube. Give your answer to the nearest whole number.
- The total surface area of a cube is 864 cm^2 ; find a side of the cube.

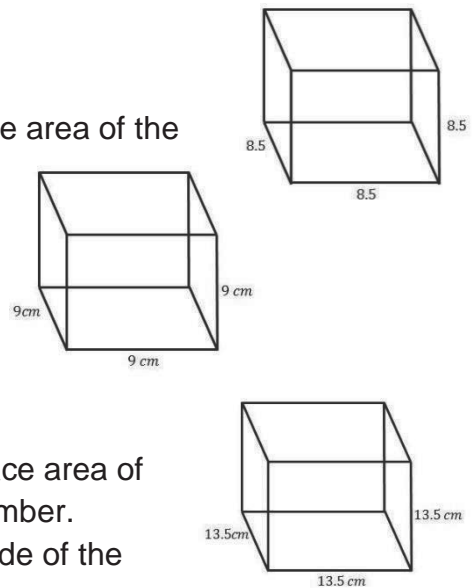

Lesson Title: Volume of a cube	Theme: Mensuration
Lesson Number: PHM3-L031	Class: SSS 3
 Learning Outcome By the end of the lesson, you will be able to calculate the volume of a cube using the appropriate formula.	

Overview

The volume of a three-dimensional solid is a measurement of the space occupied by the shape. The volume of a cube is given by the formula:

$$V = l^3 \text{ where } l \text{ is the side length of the cube}$$

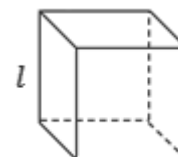

If we know the area, A of the face of the cube, then the volume is:

$$V = Al$$

Solved Examples

- Find the volume of a cube of side length $l = 7.5$ cm. Give your answer to 3 significant figures.

Solution:

Step 1. Assess and extract the given information from the problem.

Given: cube of side length = 7.5 cm

Step 2. Substitute into the appropriate formula.

$$\begin{aligned} \text{volume } V &= l^3 \\ &= 7.5^3 \\ &= 421.875 \end{aligned}$$

Step 3. Write the answer.

The volume of the cube = 422 cm^3 to 3 s.f.

- A cube has volume of 593 cm^3 . What is the length of the side of the cube? Give your answer to the nearest cm.

Solution:

Given: cube with volume = 593 cm^3

$$\begin{aligned} \text{volume } V &= l^3 \\ 593 &= l^3 \\ l &= \sqrt[3]{593} \\ &= 8.401 \\ l &= 8 \text{ cm} \end{aligned}$$

The length of the cube is 8 cm to the nearest cm.

- Find the volume of a cube whose length is 5 cm.

Solution:

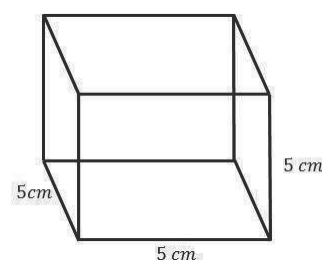

$$\begin{aligned}
 \text{volume} &= l^3 \\
 &= 5^3 \\
 &= 125 \text{ cm}^3
 \end{aligned}$$

4. The volume of a cube is $2,744 \text{ m}^3$; find the length of one of its sides.

Solution:

$$\begin{aligned}
 \text{volume} &= l^3 \\
 2,744 &= l^3 \\
 l &= \sqrt[3]{2,744} \\
 l &= 14 \text{ cm}
 \end{aligned}$$

5. How many cubes of sugar with sides of 5 cm may be packed in a box measuring 15 cm?

Solution:

Volume of cube
with sides 5 cm

$$\begin{aligned}
 \text{volume} &= l^3 \\
 &= 5^3 \\
 &= 125 \text{ cm}^3
 \end{aligned}$$

Volume of box
measuring 15 cm

$$\begin{aligned}
 \text{volume} &= l^3 \\
 &= 15^3 \\
 &= 3,375 \text{ cm}^3
 \end{aligned}$$

$$\begin{aligned}
 \text{Number of cubes} &= \frac{3,375 \text{ cm}^3}{125 \text{ cm}^3} \\
 &= 27
 \end{aligned}$$

6. The edges of a cube are 8.5 cm long. Find its volume. Give your answer to the nearest whole number.

Solution:

$$\begin{aligned}
 \text{volume} &= l^3 \\
 &= 8.5^3
 \end{aligned}$$

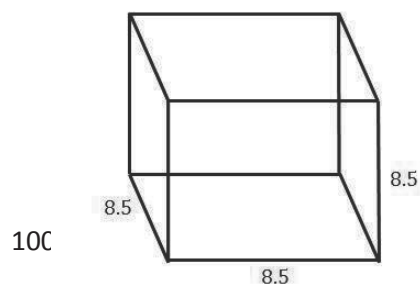



$$= 614.125 \text{ cm}^3$$

$$= 614 \text{ cm}^3$$

Practice

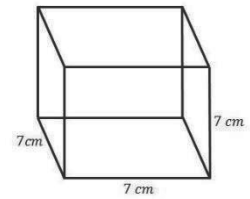
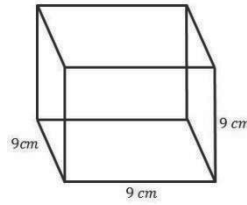
1. The volume of a cube is 125 cm^3 . Find the length of one of its sides.
2. Find the volume of a cube whose length is 7 cm.
3. The volume of a cube is 512 cm^3 . Find its total surface area.
4. The edges of a cube are 9 cm long. Find its volume.
5. How many cubes of sugar of sides 6 cm may be packed in a box measuring 12 cm?
6. How many cubes of sugar of sides 3cm may be packed in a box measuring 18 cm?



Lesson Title: Surface area of a cuboid	Theme: Mensuration
Lesson Number: PHM3-L032	Class: SSS 3
 Learning Outcome By the end of the lesson, you will be able to calculate the surface area of a cuboid using the appropriate formula.	

Overview

A cuboid is a solid with 6 rectangular faces. Each pair of opposite faces are equal.

The net of the cuboid helps in finding the surface area of each of the faces.

The surface area is the **sum of the areas** of the faces of the cuboid.

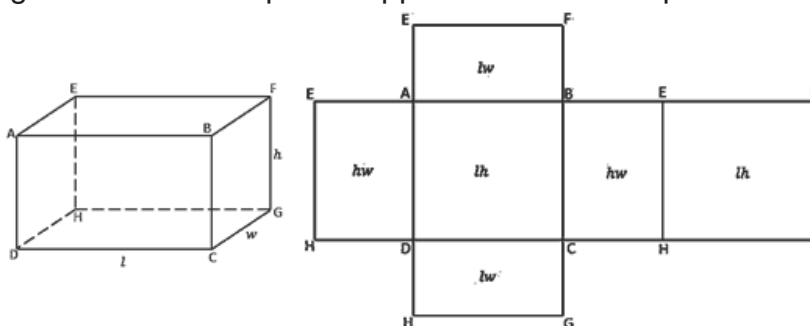

$$\begin{aligned}
 \text{surface area} &= \text{area of } ABCD + \text{area of } EFGH + \text{area of } EADH \\
 &\quad + \text{area of } BFGC + \text{area of } EFBA + \text{area of } DCGH \\
 &= lh + lh + hw + hw + lw + lw \\
 \text{surface area} &= 2(lh + hw + lw)
 \end{aligned}$$

Solved Examples

1. Draw a net of the cuboid shown below. Use the net to find the surface area of the cuboid.

Solution:

Step 1. Assess and extract the given information from the problem.

Given: cuboid with $l = 6 \text{ cm}$, $h = 4 \text{ cm}$, $w = 5 \text{ cm}$

Step 2. Draw the net of the cuboid. There are at least 50 different ways.

Step 3. Find the individual areas for each rectangular face of the cuboid.

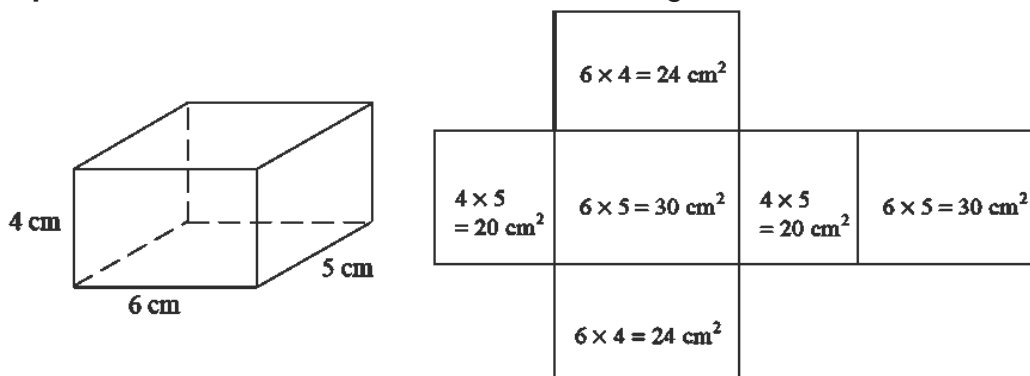

Step 4. Find the sum of the areas of the faces of the net.

$$\text{surface area} = 2(lh + hw + lw)$$

$$= 2 \times (24 + 20 + 30)$$

$$\text{surface area} = 2 \times 74 = 148$$

Step 5. Write the final answer.

The surface area of the cuboid = 148 cm².

2. A piece of cardboard, 40 cm squared has small squares of side 3.5 cm cut from each corner as shown in the diagram. The sides are then folded along the dotted lines to form an open box of height 3.5 cm. Calculate the total surface area of the open box.

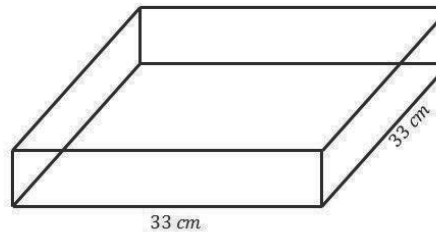
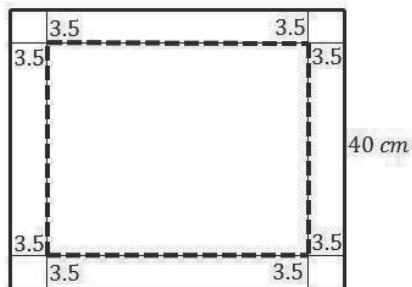

Solution:

$$\begin{aligned} \text{Length of box} &= 40 - (3.5 \times 2) &= 40 - 7 &= 33 \text{ cm} \\ \text{Breadth of box} &= 40 - (3.5 \times 2) &= 40 - 7 &= 33 \text{ cm} \end{aligned}$$

$$\begin{aligned} \text{Total surface area of box} &= 4(33 \times 3.5) + 33 \times 33 \\ &= 462 + 1089 \\ &= 1,551 \text{ cm}^2 \end{aligned}$$

3. The length of a cuboid is 10 cm. Its breadth is 6 cm and its height is 4 cm. Find its surface area.

Solution:

$$\begin{aligned} \text{Surface area} &= 2(lh + hw + lw) \\ &= 2((10 \times 4) + (4 \times 6) + (10 \times 6)) \\ &= 2(40 + 24 + 60) \\ &= 2(124) \\ &= 248 \text{ cm}^2 \end{aligned}$$

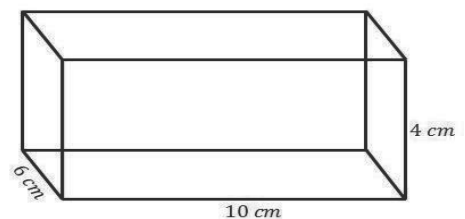

4. The surface area of water tank is 6,680 cm². If its length and breadth are 40 cm and 36 cm respectively. Find the height of the water tank.

Solution:

$$\begin{aligned} \text{Surface area of water tank} &= 2(lh + hw + lw) \\ 6,680 &= 2(40 \times 36 + 40 \times h + 36 \times h) \end{aligned}$$

$$6,680 = 2(1,440 + 40h + 36h)$$

$$6,680 = 2(1,440 + 76h)$$

$$6,680 = 2,880 + 152h$$

$$152h = 6,680 - 2,880$$

$$152h = 3,800$$

$$\frac{152h}{152} = \frac{3,800}{152}$$

$$h = 25 \text{ cm}$$

Height of water tank = 25 cm

Practice

1. A piece of cardboard is 20 cm squared and has small squares of side 2.5 cm cut from each corner as shown in the diagram at right. The sides are then folded along the dotted lines to form an open box of height 2.5 cm. Calculate the total surface area of the open box.
2. The surface area of box is 208 cm^2 . If its length and height are 8 cm and 4 cm respectively, find the width of the water tank.
3. The length of a cuboid is 12 cm. Its breadth is 8 cm and its height is 6 cm. Find its surface area.
4. Find the surface area of cuboids with these dimensions:
 - a. Length 8 cm, breadth 5 cm and height 4 cm.
 - b. Length 10 cm, breadth 7 m and height 4 cm.
5. The surface area of chalk box is 68 cm^2 . If its length and width are 6 cm and 1 cm respectively, find the height of the water tank.
6. The surface area of a water tank is 792 cm^2 . If its width and height are 12 cm and 8 cm respectively, find the length of the water tank.

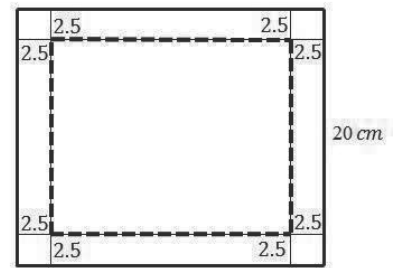

Lesson Title: Volume of a cuboid	Theme: Mensuration
Lesson Number: PHM3-L033	Class: SSS 3
 Learning Outcome By the end of the lesson, you will be able to calculate the volume of a cuboid using the appropriate formula.	

Overview

The cuboid shown at right has length, l , width w and height h .
 The volume of the cuboid is given by the formula:

$$V = \text{length} \times \text{width} \times \text{height} = lwh$$

If we know the area A of the base of the cube then the volume is:

$$V = Ah$$

The formula $V = A \times \text{height}$ can be used to find the volume given the area and the corresponding height of any of the faces.

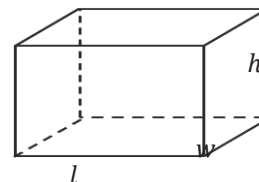

Solved Examples

- Find the volume of the given cuboid.

Solution:

Step 1. Assess and extract the given information from the problem.

Given: cuboid with $l = 6 \text{ cm}$, $w = 5 \text{ cm}$, $h = 4 \text{ cm}$

Step 2. Substitute into the appropriate formula.

$$\begin{aligned} \text{Volume} &= lwh \\ &= 6 \times 5 \times 4 \\ &= 120 \end{aligned}$$

Step 3. Write the answer.

$$\text{Volume} = 120 \text{ cm}^3$$

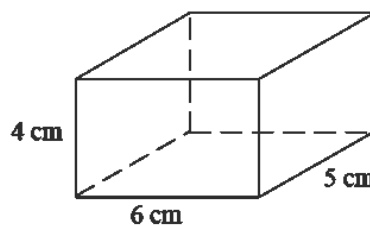

- A car's petrol tank is 0.8 m long, 25 cm wide and 20 cm deep. How many litres of petrol can it hold?

Solution:

Length = 0.8 m = $0.8 \times 100 = 80 \text{ cm}$

Width = 25 cm

Depth = 20 cm

$$\begin{aligned} \text{Volume of petrol tank} &= 80 \text{ cm} \times 25 \text{ cm} \times 20 \text{ cm} \\ &= 40,000 \text{ cm}^3 \\ &= \frac{40,000}{1,000} \text{ litres} \\ &= 40 \text{ litres} \end{aligned}$$

3. A water tanks is 1.2 m square and 1.35 m deep. It is half full of water. How many times can a 9-litre bucket be filled from the tank?

Solution:

$$1.2 \text{ m} = 120 \text{ cm and}$$

$$1.35 \text{ m} = 135 \text{ cm}$$

$$\begin{aligned} \text{Volume of water tank} &= 120 \text{ cm} \times 120 \text{ cm} \times 135 \text{ cm} \\ &= 1,944,000 \text{ cm}^3 \\ &= \frac{1,944,000 \text{ cm}^3}{1,000} \\ &= 1,944 \text{ litres} \end{aligned}$$

4. The volume of a cuboid is 60 cm^3 . Its length is 10 cm and its breadth is 4 cm. Find its height.

Solution:

$$\text{Volume} = L \times b \times h$$

$$60 \text{ cm}^3 = 10 \text{ cm} \times 4 \text{ cm} \times h$$

$$60 \text{ cm}^3 = 40 \text{ cm}^2 \times h$$

$$40 \text{ cm}^2 \times h = 60 \text{ cm}^3$$

$$\frac{40 \text{ cm}^2 \times h}{40 \text{ cm}^2} = \frac{60 \text{ cm}^3}{40 \text{ cm}^2}$$

$$h = 1.5 \text{ cm}$$

$$\text{Height} = 1.5 \text{ cm}$$

5. The volume of a cuboid is 400 cm^3 . Its length is 10 cm and its height is 8 cm. Find its breadth.

Solution:

$$\text{Volume} = L \times b \times h$$

$$400 \text{ cm}^3 = 10 \text{ cm} \times b \times 8 \text{ cm}$$

$$400 \text{ cm}^3 = 80 \text{ cm}^2 \times b$$

$$80 \text{ cm}^2 \times b = 400 \text{ cm}^3$$

$$\frac{80 \text{ cm}^2 \times b}{80 \text{ cm}^2} = \frac{400 \text{ cm}^3}{80 \text{ cm}^2}$$

$$b = 5 \text{ cm}$$

$$\text{Breadth} = 5 \text{ cm}$$

6. A room measures 10 m by 6 m by 3m. The volume of airspace needed for one person is 5 m^3 . Find the maximum number of people who may use the room at the same time.

Solution:

$$\text{Volume of room} = L \times b \times h$$

$$= 10 \text{ m} \times 6 \text{ m} \times 3 \text{ m}$$

$$= 180 \text{ m}^3$$

$$\text{Maximum number of people} = \frac{180 \text{ m}^3}{5 \text{ m}^3}$$

$$= 36$$

7. How many packets of tea bags measuring 12 cm by 4 cm by 4 cm may be packed in a box measuring 48 cm by 24 cm by 16 cm?

Solution:

$$\begin{aligned}\text{Volume of tea bag} &= L \times b \times h \\ &= 12 \text{ cm} \times 4 \text{ cm} \times 4 \text{ cm} \\ &= 192 \text{ cm}^3 \\ \text{Volume of box} &= L \times b \times h \\ &= 48 \text{ cm} \times 24 \text{ cm} \times 16 \text{ cm} \\ &= 18,432 \text{ cm}^3 \\ \text{Number of tea bags} &= \frac{\text{volume of box}}{\text{volume of tea bag}} \\ &= \frac{18,432 \text{ cm}^3}{192 \text{ cm}^3} \\ &= 96\end{aligned}$$

Practice

- Find the volume of cuboids with these dimensions:
 - Length 8 cm, breadth 5 cm and height 4 cm.
 - Length 10 cm, breadth 7cm and height 4 cm.
- The length of a cuboid is 2 m; its breadth is 30 cm and its height is 20 cm. Find its volume in cm^3 .
- A water tank measures 1.4 m by 80 cm by 60 cm. Find its capacity (the volume of water it can hold) in litres.
- A rectangular tank is 76 cm long, 50 cm wide and 40 cm high. How many litres of water can it hold?
- A rectangular tank has dimensions of 4.5 m by 6 m by 8 m. It is filled with water to the brim. If 58 m^3 of the water is used, how much water is left in the tank?
- A rectangular tank has a length of 4 m, a width of 12 m and a height of 3.5 m. If the tank is filled with water to $\frac{2}{3}$ of its capacity, calculate the volume of the water in the tank.

Lesson Title: Nets of Prisms	Theme: Mensuration
Lesson Number: PHM3-L034	Class: SSS 3
 Learning Outcome By the end of the lesson, you will be able to draw nets of prisms.	

Overview

This lesson focuses on drawing nets of prisms.

A prism is a solid object with 2 identical ends and flat sides. The cross-section of the prism is the same all along its length. The shape of the ends of the prism is sometimes used to name the prism. In order to draw nets of prisms, we need to know the number and type of the individual shapes which they are made of.

Example of prisms include cubes (square prisms), cuboids (rectangular prisms), triangular prisms and cylinders.

Solved Examples

1. Draw an accurate net of the given prisms.

Solution:

Step 1. Assess and extract the given information from the problem.

Given: cuboid with $l = 4$ cm, $h = 1$ cm, $w = 3$ cm

Step 2. Draw the net of the solid – shown below

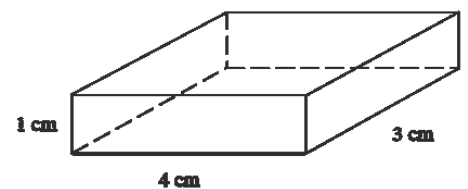
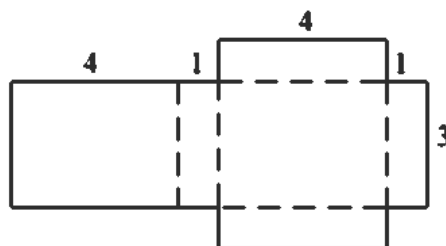

2. Draw the nets of the given solids:
Solution is shown next to each solid.

a.

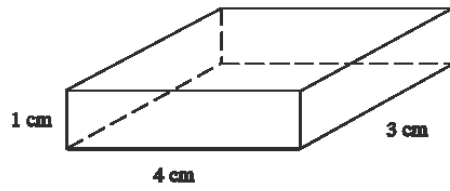

b.

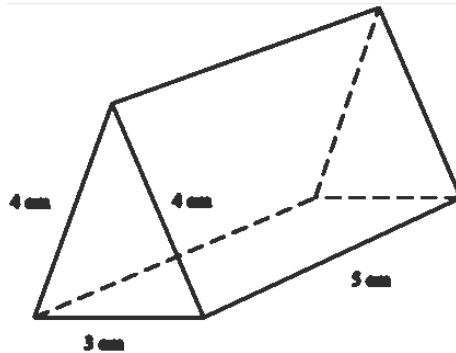

c.

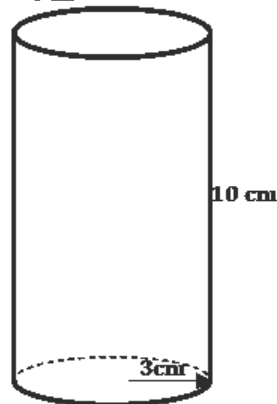

d.

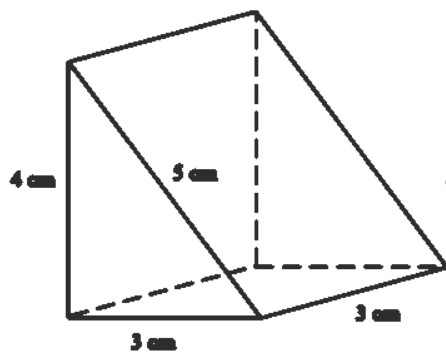

Solutions

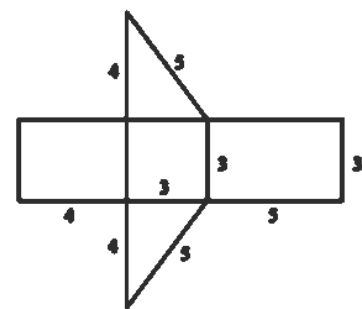
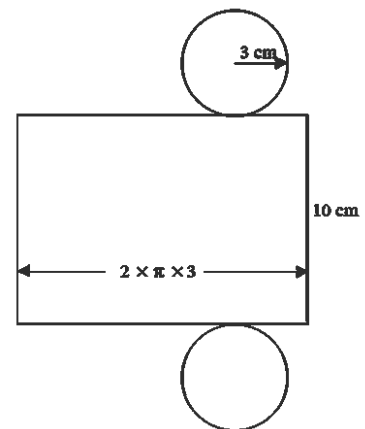
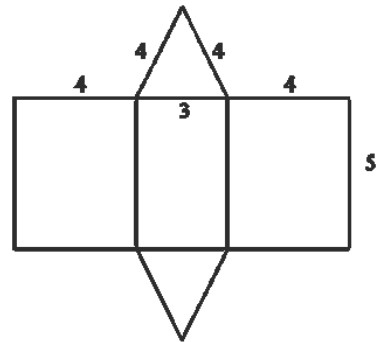
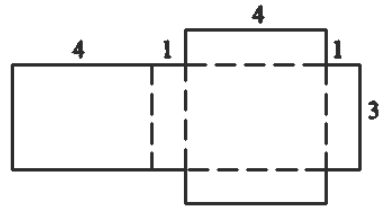

Practice

1. Draw the nets of the following solids:

i.

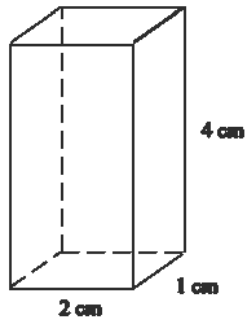

ii.

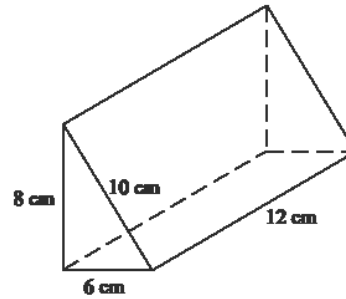

2. Which of the following does not make a net of the given shape?

i.

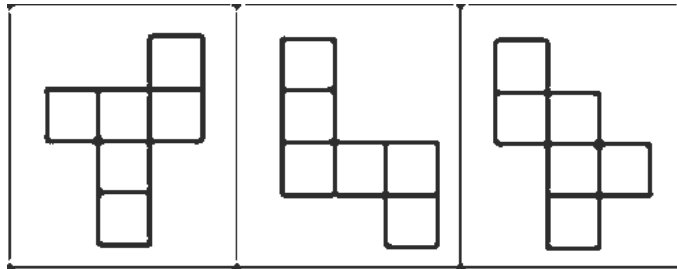
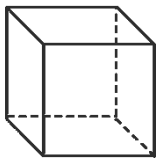

ii.

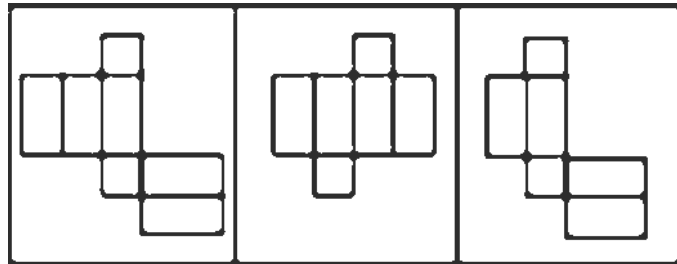
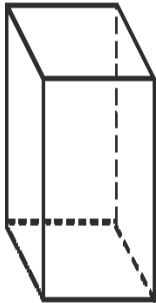

3. Draw the shape with the given net.

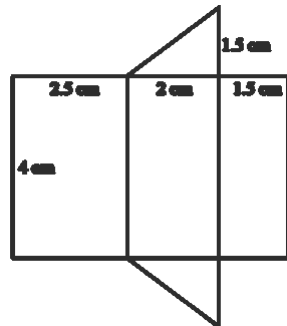

Lesson Title: Surface area of a triangular prism	Theme: Mensuration
Lesson Number: PHM3-L035	Class: SSS 3
 Learning Outcome By the end of the lesson, you will be able to calculate the surface area of a triangular prism using the appropriate formula.	

Overview

The basic method of finding surface areas of any solid is to find the area of the individual faces, then add up the areas. This method will be used to find the surface area of a triangular prism.

Solved Examples

1. Draw the net of the triangular prism. Use it to find the surface area of the given prisms. Give answers to the nearest cm^2 .

Solution:

Step 1. Assess and extract the given information from the problem.
 Given: triangular prism with side lengths as shown

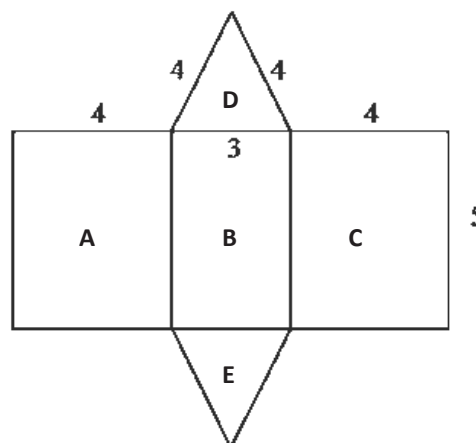
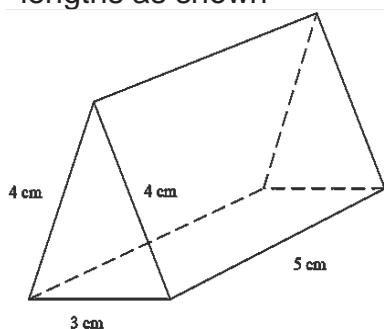

Step 2. Draw the net of the triangular prism. (shown above)

Step 3. Find the areas for each face of the triangular prism.

$$\begin{aligned} \text{surface area} &= \text{area of rectangle A} + \text{area of rectangle B} + \text{area of} \\ &= \text{rectangle C} + \text{area of triangle D} + \text{area of triangle E} \end{aligned}$$

Method 1.

$$\begin{aligned} \text{area of rectangle A} &= \text{area of rectangle C} \\ &= 4 \times 5 = 20 \text{ cm}^2 \\ \text{area of rectangle B} &= 3 \times 5 = 15 \text{ cm}^2 \\ \text{area of triangle D} &= \text{area of triangle E} \end{aligned}$$

$$\begin{aligned}
 &= \frac{1}{2} \times 3 \times h && \text{where } h \text{ is the height of the triangle} \\
 \text{Find } h: &4^2 = h^2 + 1.5^2 && \text{Pythagoras' Theorem} \\
 &h^2 = 16 - 2.25 = 13.75 \\
 &h = \sqrt{13.75} \\
 &= 3.708 \text{ cm} \\
 \text{area of triangle D} &= \frac{1}{2} \times 3 \times 3.708 \\
 &= 5.562 \text{ cm}^2
 \end{aligned}$$

Step 4. Find the sum of the areas of the faces of the net.

$$\begin{aligned}
 \text{surface area} &= 20 + 15 + 20 + 5.562 + 5.562 \\
 &= 66.124
 \end{aligned}$$

Step 5. Write the final answer.

The surface area of the triangular prism = 66 cm² to the nearest cm².

2. Calculate the surface area of the prism. All dimensions are in cm.

Solution:

$$\begin{aligned}
 QR^2 &= PQ^2 + PR^2 \\
 QR^2 &= 8^2 + 6^2 \\
 QR^2 &= 100 \\
 QR &= \sqrt{100} \\
 QR &= 10 \text{ cm} \\
 \text{area of } \triangle ABC &= \frac{1}{2} \times 8 \times 6 \\
 &= 24 \text{ cm}^2 \\
 \text{area of } APQB &= 20 \times 8 \\
 &= 160 \text{ cm}^2 \\
 \text{area of } APRC &= 20 \times 6 \\
 &= 120 \text{ cm}^2 \\
 \text{area of } BQRC &= 20 \times 10 \\
 &= 200 \text{ cm}^2 \\
 \text{Surface area} &= 2(\text{Area of } \triangle ABC) + \text{Area of} \\
 &\quad APQB + \text{Area of } APRC + \\
 &\quad \text{Area of } BQRC \\
 &= 2(24) + 160 + 120 + 200 \\
 &= 48 + 160 + 120 + 200 \\
 &= 528 \text{ cm}^2
 \end{aligned}$$

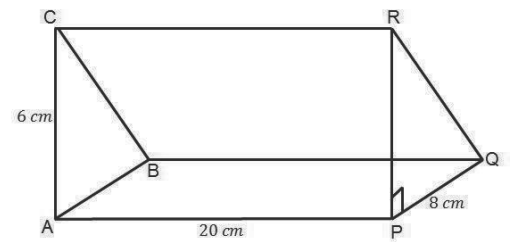

3. Calculate the surface area of the prism at right. All dimensions are in cm.

Solution:

Let M be the mid-point of EF

$$FD^2 = EM^2 + MD^2$$

$$6^2 = 4^2 + MD^2$$

$$MD^2 = 6^2 - 4^2$$

$$= 36 - 16 = 20$$

$$MD = \sqrt{20} = 4.47$$

$$= 4.5 \text{ cm}$$

$$\text{area of } \triangle DEF = \frac{1}{2} \times 8 \times 4.5$$

$$= 18 \text{ cm}^2$$

$$\text{area of } BEDC = 27 \times 6$$

$$= 162 \text{ cm}^2$$

$$\text{area of } ABEF = 27 \times 8$$

$$= 216 \text{ cm}^2$$

$$\text{Surface area} = 2(\text{Area of } \triangle DEF) + 2(\text{Area of } BEDC) + \text{Area of } ABEF$$

$$= 2(18) + 2(162) + 216$$

$$= 36 + 324 + 216$$

$$= 576 \text{ cm}^2$$

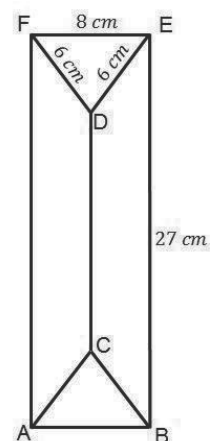

Practice

1. Calculate the surface areas of the following prisms. All dimensions are in cm. Give your answer to 3 significant figures.

a.

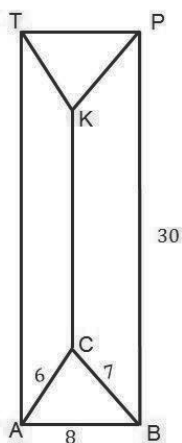

b.



c.

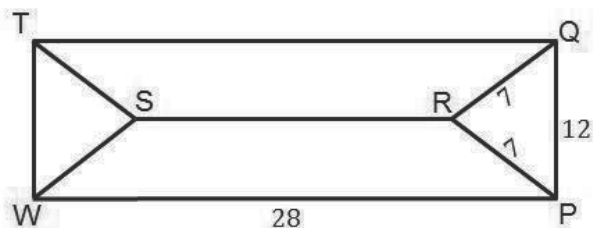

Lesson Title: Volume of a Triangular Prism	Theme: Mensuration
Lesson Number: PHM3-L036	Class: SSS 3
 Learning Outcome By the end of the lesson, you will be able to calculate the volume of a triangular prism using the appropriate formula.	

Overview

The formula for the volume of a cuboid or rectangular prism can be used to find the volume of all prisms.

If we know the area A of the cross-section of the prism then the volume can be defined as:

$$V = Al \text{ where } l \text{ is the length of the prism}$$

We will use the prisms from previous lessons to practice how to find the volumes of triangular prisms.

Solved Examples

1. Find the volume of the given prism. Give answers to a reasonable accuracy.

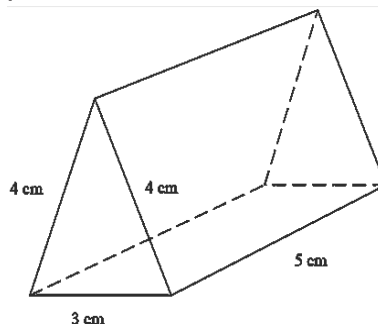

Solution:

Find the area A of the cross-section using the appropriate formula. Note that in order to find the area, you must first find the height of the triangle using Pythagoras' theorem.

Step 1. Calculate the Area:

$$\begin{aligned} \text{area of cross-section } A &= \frac{1}{2}bh && \text{where } b \text{ is the base and } h \text{ is} \\ &= \frac{1}{2} \times 3 \times h && \text{the height of the triangle} \end{aligned}$$

Find the height h :

$$\begin{aligned} 4^2 &= h^2 + 1.5^2 && \text{Pythagoras' Theorem} \\ h^2 &= 16 - 2.25 = 13.75 \\ h &= \sqrt{13.75} = 3.708 \end{aligned}$$

$$A = \frac{1}{2} \times 3 \times 3.708$$

$$A = 5.562 \text{ cm}^2$$

Step 2. Calculate the volume:

$$\begin{aligned} \text{Volume, } V &= Al \\ &= 5.562 \times 5 \\ V &= 27.81 \end{aligned}$$

Step 3. Write the answer.

The volume of the triangular prism = 27.8 cm^3 to 1 decimal place.

2. Calculate the volume of the prism below. All dimensions are in cm.

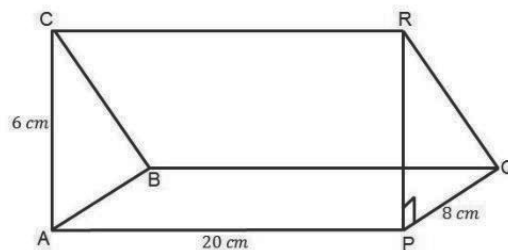

Solution:

$$\begin{aligned} \text{area of } \triangle ABC &= \frac{1}{2} \times 8 \times 6 \\ &= 24 \text{ cm}^2 \end{aligned}$$

$$\begin{aligned} \text{Volume of prism} &= \text{Area of cross-section} \times \text{height} \\ &= \text{Area of } \triangle ABC \times \\ &\quad \text{height} \\ &= 24 \times 20 \\ &= 480 \text{ cm}^3 \end{aligned}$$

3. Calculate the surface area of the prism. All dimensions are in cm.

Solution:

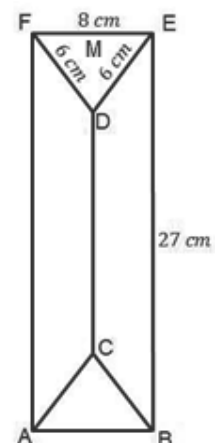

Let M be the mid-point of EF. Use Pythagoras' theorem to find MD, the height of the triangle:

$$\begin{aligned}
 FD^2 &= EM^2 + MD^2 \\
 6^2 &= 4^2 + MD^2 \\
 MD^2 &= 6^2 - 4^2 \\
 &= 36 - 16 = 20 \\
 MD &= \sqrt{20} = 4.47 \\
 &= 4.5 \text{ cm}
 \end{aligned}$$

Find the area of $\triangle DEF$:

$$\begin{aligned}
 A &= \frac{1}{2} \times 8 \times 4.5 \\
 &= 18 \text{ cm}^2
 \end{aligned}$$

Find the volume of the prism:

$$\begin{aligned}
 V &= \text{Area of } \triangle DEF \times \text{height} \\
 &= 18 \times 27 \\
 &= 483.03 \text{ cm}^3
 \end{aligned}$$

Practice

1. Calculate the volumes of the following prisms. All dimensions are in cm. Give your answers to 3 significant figures.

a.

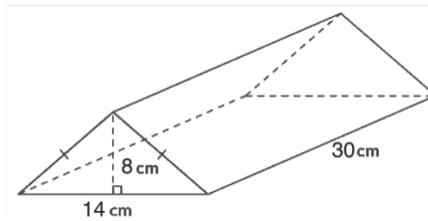

b.

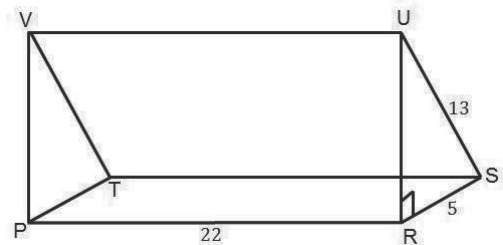

c.



Lesson Title: Surface area of a cylinder	Theme: Mensuration
Lesson Number: PHM3-L037	Class: SSS 3
 Learning Outcome By the end of the lesson, you will be able to calculate the surface area of a cylinder using the appropriate formula.	

Overview

A cylinder is a prism with a circular cross-section. If we cut across the cylinder, the end faces will always be circular.

If we cut along the height of the cylinder and flatten the resulting shape, we get a rectangle with a width equal to the curved surface.

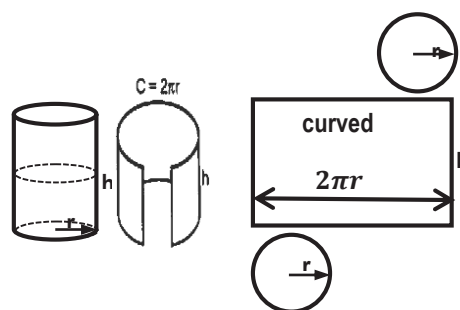

[NOTE: This can be shown practically using a rolled up piece of paper]

The width of the curved surface equals the circumference of the circle.

The cylinder is made up of 3 pieces – 2 circular end faces and a curved surface ($2\pi r$), where r is the radius of the cylinder.

A **solid** cylinder will always have these 3 pieces.

A **hollow** cylinder with one end open will have 2 pieces – one circular end face and the curved surface.

A hollow cylinder with both ends open will have just 1 piece – the curved surface only. Assume a cylinder is solid unless otherwise stated.

As before the basic method of finding surface areas of a solid is to find the area of the individual faces, then add up the areas.

$$\begin{aligned}
 \text{surface area of solid cylinder} &= \text{area of circular end faces} + \text{area of curved surface} \\
 \text{area of circular end faces} &= 2 \times \pi r^2 && \text{since there are 2 end faces} \\
 &= 2\pi r^2 \\
 \text{area of curved surface} &= 2\pi r \times h && \text{area of rectangle width } 2\pi r \text{ height, } h \\
 &= 2\pi r h \\
 \text{surface area of solid cylinder} &= 2\pi r^2 + 2\pi r h \\
 &= 2\pi r(r + h)
 \end{aligned}$$

surface area of hollow cylinder with one end open = $\pi r^2 + 2\pi rh$ since there is only 1 end face

$$= \pi r(r + 2h)$$

surface area of hollow cylinder with both ends open = $2\pi rh$ since there are no end faces

Solved Examples

1. Find the total surface area of the cylinder shown. Use $\pi = \frac{22}{7}$

Solution:

Step 1. Assess and extract the given information from the problem.

Given: cylinder with radius $r = 7$ cm and height $h = 10$ cm

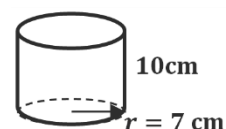

Step 2. Draw the net of the cylinder.

Step 3. Find the sum of the areas of the faces of the net.

surface area = area of circular end faces + area of curved surface

Step 4. Find the surface area of the cylinder.

$$\begin{aligned} \text{surface area} &= 2\pi r^2 + 2\pi rh \\ &= 2\pi r(r + h) \\ &= 2 \times \frac{22}{7} \times 7 \times (7 + 10) \\ &= 2 \times 22 \times 17 \\ \text{surface area} &= 748 \text{ cm}^2 \end{aligned}$$

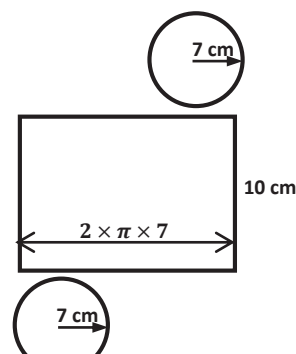

Step 5. Write the final answer.

The surface area of the cylinder is 748 cm^2 .

2. Calculate the surface area of a hollow cylinder which is closed at one end, if the base radius is 3.5 cm and the height is 8 cm. [Use $\pi = \frac{22}{7}$]

Solution:

$$\begin{aligned} \text{surface area} &= \pi r^2 + 2\pi rh \\ &= \pi r(r + 2h) \\ &= \frac{22}{7} \times 3.5 \times (3.5 + (2 \times 8)) \\ &= 214.5 \text{ cm}^2 \end{aligned}$$

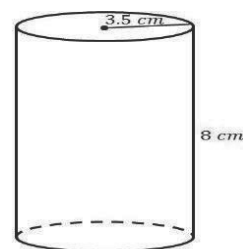

3. A cylindrical container closed at both ends, has a radius 7 cm and height 5 cm. Find the total surface area of the container.

Solution:

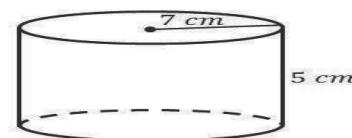

$$\begin{aligned}
\text{surface area} &= 2\pi r(r + h) \\
&= 2 \times \frac{22}{7} \times 7(7 + 5) \\
&= 44(12) \\
&= 528 \text{ cm}^2
\end{aligned}$$

4. The curved surface area of a cylindrical tin is 704 cm^2 . Calculate the height when the radius is 8 cm . [Use $\pi \frac{22}{7}$]

Solution:

$$\begin{aligned}
\text{curved surface area} &= 2\pi r h \\
704 &= 2 \times \frac{22}{7} \times 8 \times h \\
704 &= \frac{352h}{7} \\
352h &= 704 \times 7 = 4,928 \\
\frac{352h}{352} &= \frac{4,928}{352} \\
h &= 14 \text{ cm}
\end{aligned}$$

5. The sum of the radius and the height of a cylinder is 21 cm and the total surface area of the cylinder is 660 cm^2 . Find the height of the cylinder.

Solution:

$$\begin{aligned}
r + h &= 21 \text{ cm} && (1) \\
\text{surface area} &= 2\pi r(r + h) \\
660 &= 2 \times \frac{22}{7} \times r(21) \\
660 &= \frac{924r}{7} \\
r &= \frac{660 \times 7}{924} \\
r &= 5 \text{ cm} \\
h + 5 &= 21 \text{ cm} && \text{from equation (1)} \\
h &= 21 \text{ cm} - 5 \text{ cm} \\
h &= 16 \text{ cm} \\
\text{height of cylinder} &= 16 \text{ cm}
\end{aligned}$$

Practice

1. A solid cylinder of radius 7 cm is 10 cm long. Find its total surface area. [Use $\pi \frac{22}{7}$]
2. The curved surface area of a cylindrical tin is 1188 cm^2 . Calculate the radius when the height is 21 cm . [Use $\pi \frac{22}{7}$]
3. Find the curved surface areas and total surface areas of the following cylinders. Use $\pi = 3.142$. Give all answers to the nearest whole number.

a.

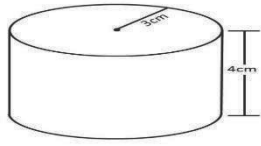

b.

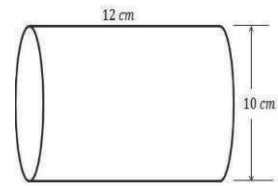

c.

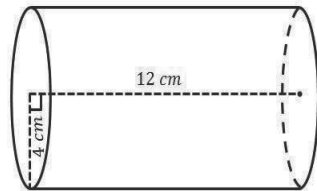

d.

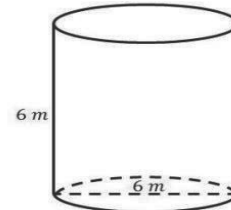

4. Calculate, in terms of π , the total surface area of a solid cylinder of radius 3 cm and height 4 cm.
5. The diameter of a cylinder is 4 cm and its height is 21 cm. Find its surface area.

Lesson Title: Volume of a cylinder	Theme: Mensuration	
Lesson Number: PHM3-L038	Class: SSS 3	Time: 40 minutes
 Learning Outcome By the end of the lesson, you will be able to calculate the volume of a cylinder using the appropriate formula.		

Overview

We can use the formula for the volume of a cuboid or rectangular prism to find the volume of all prisms.

If we know the area A of the cross-section of the prism then the volume
Volume, $V = Al$ where l is the length of the prism.

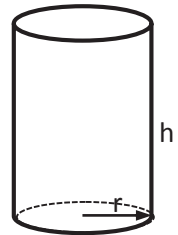

The area of the cross-section of the cylinder $A = \pi r^2$.

We find the volume of the cylinder using the formula:

$$\begin{aligned} \text{Volume, } V &= Al \\ &= \pi r^2 \times h \quad \text{since } l = h \text{ for a cylinder} \end{aligned}$$

There are 2 other types of volumes we can find for a cylinder.

This usually occurs when we have a pipe in the form of a hollow cylinder such as shown right.

The cylindrical pipe shown at right has an outside or external radius R and an inside or internal radius r .

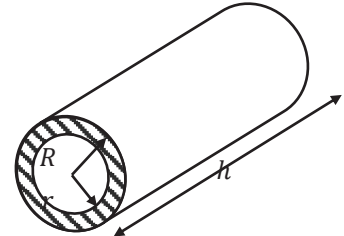

The cross-section of the pipe is shown shaded in the diagram.

The **volume of material** used to make the pipe is given by:

$$\begin{aligned} \text{Volume, } V &= Ah \quad \text{since } l = h \text{ for a pipe} \\ \text{But } A &= \text{area of circle radius } R - \text{area of circle radius } r \\ &= \pi R^2 - \pi r^2 \\ &= \pi(R^2 - r^2) \\ \therefore V &= \pi(R^2 - r^2)h \\ &= \pi h(R^2 - r^2) \end{aligned}$$

The **volume of any liquid** flowing through the pipe is given by:

$$\begin{aligned} \text{Volume, } V &= Ah \\ &= \pi r^2 h \quad \text{where } r \text{ is the internal radius of the pipe} \end{aligned}$$

Solved Examples

1. Find the volume of the given cylinder. Use $\pi = \frac{22}{7}$.

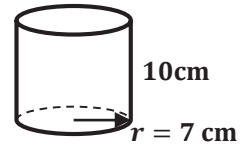

Solution:

Step 1. Assess and extract the given information from the problem.

Given: cylinder with radius $r = 7 \text{ cm}$ and height $h = 10 \text{ cm}$

Step 2. Find the area A of the cross-section using the appropriate formula

$$\begin{aligned} \text{area of cross-section } A &= \pi r^2 && \text{where } r \text{ is the radius of} \\ & && \text{the circle} \\ &= \frac{22}{7} \times 7^2 \\ &22 \times 7 = 154 \end{aligned}$$

Step 3. Substitute into the appropriate formula.

$$\begin{aligned} \text{Volume, } V &= Ah \\ &= (\pi r^2)h \\ &= 154 \times 10 \\ V &= 1,540 \text{ cm}^3 \end{aligned}$$

Step 4. Write the answer.

The volume of the cylinder = $1,540 \text{ cm}^3$.

2. Find the volume of a cylinder of radius 14 cm and height 16 cm . Use $\pi = 3.142$. Give your answer to 3 significant figures.

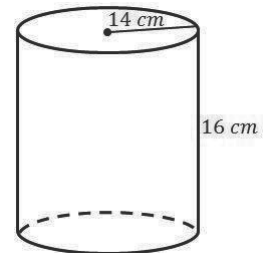

Solution:

$$\begin{aligned} \text{Volume} &= \pi r^2 h \\ &= 3.142 \times 14^2 \times 16 \\ &= 9,853.312 \text{ cm}^3 \\ &= 9,850 \text{ cm}^3 \end{aligned}$$

3. A circular metal sheet 48 cm in diameter and 2 mm thick is melted and recast into a cylindrical bar 6 cm in diameter. How long is the bar?

Solution:

$$\begin{aligned} r &= \frac{48}{2} = 24 \text{ cm} \\ 2 \text{ mm} &= \frac{2}{10} = \frac{1}{5} \text{ cm} \end{aligned}$$

Let p = length of metal bar

Volume of circular metal sheet = Volume of metal bar

$$\begin{aligned} \frac{22}{7} \times 24^2 \times \frac{1}{5} &= \frac{22}{7} \times 3^2 \times p \\ \frac{12,672}{35} &= \frac{198p}{7} \\ 35 \times 198p &= 12,672 \times 7 \\ 6,930p &= 88,704 \\ \frac{6,930p}{6,930} &= \frac{88,704}{6,930} \\ p &= 12.8 \text{ cm} \end{aligned}$$

4. How many cylindrical glasses 6 cm in diameter and 10 cm deep can be filled from a cylindrical jug 10 cm in diameter and 18 cm deep?

Solution:

$$\begin{aligned}
 r &= \frac{6}{2} &&= 3 \text{ cm} \\
 \text{Volume of cylindrical glass} &= \frac{22}{7} \times 3^2 \times 10 \\
 &= \frac{1,980}{7} \text{ cm}^3 \\
 r &= \frac{10}{2} &&= 5 \text{ cm} \\
 \text{Volume of cylindrical jug} &= \frac{22}{7} \times 5^2 \times 18 \\
 &= \frac{9,900}{7} \\
 \text{Number of cylindrical glasses} &= \frac{\text{volume of cylindrical jug}}{\text{volume of cylindrical glass}} \\
 &= \frac{9,900}{\frac{1,980}{7}} \\
 &= \frac{9,900}{7} \times \frac{7}{1,980} \\
 &= \frac{9,900}{1,980} \\
 &= 5
 \end{aligned}$$

Practice

- Find the volume of a cylinder of radius 9cm and height 14cm. Use $\pi=3.142$. give your answer to 3 significant figures.
- A circular metal sheet 12 cm in radius and 8mm thick is melted and recast into a cylindrical bar 4 cm in radius. How long is the bar?
- A cylindrical shoe polishing is 10 cm in diameter and 3.5 cm deep. Calculate the capacity of the tin in cm^3 .
- A measuring cylinder of radius 3 cm contains water to a height of 49 cm. If this water is poured into a similar cylinder of radius 7 cm, what will be the height of the water column?
- A metal disc 12 cm in diameter and 5 cm thick is melted down and cast into a cylindrical bar of diameter 5cm. How long is the bar?
- A solid metal cylinder, 8 cm in diameter and 8 cm long is melted to be made into discs 4 cm in diameter and 5 mm thick. Assuming no wastage, how many discs can be made?

Lesson Title: Surface area of a cone	Theme: Mensuration
Lesson Number: PHM3-L039	Class: SSS 3
 Learning Outcome By the end of the lesson, you will be able to calculate the surface area of a cone using the appropriate formula.	

Overview

A sector of a circle can be bent to make the curved surface of an open cone such as the one on the board.

[NOTE: This can be shown practically using a cut out piece of paper similar to the net.]

A **solid** cone will always have 2 pieces – one circular end face or base and the curved surface created by the sector.

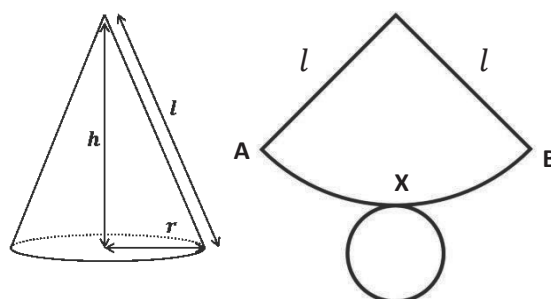

A **hollow** cone with one end open will have just one piece – the curved surface created by the sector.

Assume a cone is solid unless otherwise stated.

To find the surface area of a cone, we use the basic formula by finding the area of the individual faces adding up the areas.

surface area of cone = area of curved surface + area of circular base

Since the cone is made from the sector:

- The area of the curved surface of the cone is equal to the area of the sector.
- The length of the arc AXB is the same as the circumference of the circular base of the cone with radius r .
- The radius of the circle l is the same as the slant length of the cone.

$$\text{surface area of cone} = \text{area of curved surface} + \text{area of circular base}$$

$$\text{area of curved surface} = \frac{\theta}{360} \times \pi l^2 \quad \text{area of sector, radius } l \text{ and angle } \theta$$

$$\text{Also, length of arc AXB} = \text{circumference of circular base of cone}$$

$$\frac{\theta}{360} \times 2\pi l = 2\pi r \quad \text{since the circular base has radius } r$$

$$\therefore \frac{\theta}{360} = \frac{r}{l}$$

$$\begin{aligned}
 \text{area of curved surface} &= \frac{r}{l} \times \pi l^2 \\
 \text{area of curved surface} &= \pi r l && \text{radius } r, \text{ slant length } l \text{ of cone} \\
 \text{area of circular base} &= \pi r^2 && \text{one circular base, radius } r \\
 \therefore \text{surface area of cone} &= \pi r l + \pi r^2 && \text{add the areas} \\
 &= \pi r(l + r) \\
 \text{surface area of hollow cone} &= \pi r l && \text{since there is only the curved surface}
 \end{aligned}$$

Solved Examples

- Find the curved surface area in the cone shown if the base radius is 9 cm and slant height is 15 cm.

Solution:

Step 1. Assess and extract the given information from the problem.

Given: cone with radius $r = 9$ cm and slant height $l = 15$ cm

Step 2. Find the surface area of the cone.

$$\begin{aligned}
 \text{surface area} &= \pi r l \\
 &= 3.142 \times 9 \times 15 \\
 \text{surface area} &= 424.17
 \end{aligned}$$

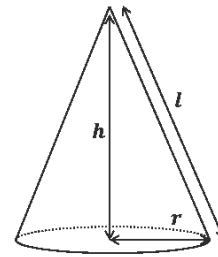

Step 3. Write the final answer.

The surface area of the cone is 424 cm² to the nearest cm².

- The curved surface area of a cone is 100 cm². If the radius of the cone is 4 cm, find the slant height of the cone. [Use $\pi = \frac{22}{7}$]

Solution:

$$\begin{aligned}
 \text{Curved surface area} &= \pi r l \\
 100 &= \frac{22}{7} \times 4 \times l \\
 100 &= \frac{88l}{7} \\
 88l &= 700 \\
 \frac{88l}{88} &= \frac{700}{88} \\
 l &= 7.95 \text{ cm}^2
 \end{aligned}$$

- The height of a right circular cone is 4 cm. The radius of its base is 3 cm. Find its curved surface area and total surface area. [Use $\pi = \frac{22}{7}$]

Solution:

$$\begin{aligned}
 \text{Curved surface area} &= \pi r l \\
 &= \frac{22}{7} \times 3 \times 4 \\
 &= \frac{264}{7} \\
 &= 37.71 \text{ cm}^2 \\
 \text{Total surface area} &= \pi r(r + l)
 \end{aligned}$$

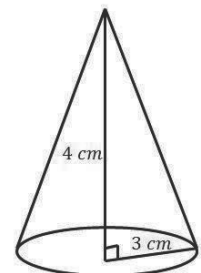

$$\begin{aligned}
&= \frac{22}{7} \times 3(3 + 4) \\
&= \frac{66}{7} \times 7 \\
&= 66 \text{ cm}^2
\end{aligned}$$

4. A sector of a circle of radius 7 cm subtending an angle of 270° at the centre of the circle is used to form a cone. Find: a. the base radius of the cone; b. the curved surface area of the cone; c. the total surface area of the cone, correct to 3 significant figures. [Use $\pi = \frac{22}{7}$]

Solution:

$$\begin{aligned}
\text{a. Base radius (r)} &= \frac{270^\circ \times 7}{360^\circ} \\
&= 5.25 \text{ cm} \\
\text{b. Curved surface area} &= \pi r l \\
&= \frac{22}{7} \times 5.25 \times 7 \\
&= 115.5 \text{ cm}^2 \\
&= 116 \text{ cm}^2 \\
\text{c. Total surface area} &= \pi r(r + l) \\
&= \frac{22}{7} \times 5.25(5.25 + 7) \\
&= 16.5(12.25) \\
&= 202.125 \text{ cm}^2 \\
&= 202 \text{ cm}^2
\end{aligned}$$

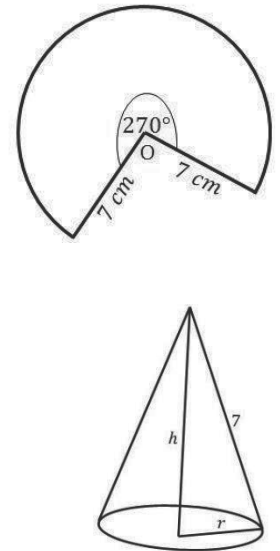

5. Calculate the curved surface area and total surface area of a solid cone of slant height 15 cm and base radius 8 cm in terms of π .

Solution:

$$\begin{aligned}
\text{Curved surface area} &= \pi r l \\
&= \pi \times 8 \times 15 \\
&= 120\pi \text{ cm}^2 \\
\text{Total surface area} &= \pi r(r + l) \\
&= \pi \times 8(8 + 15) \\
&= \pi \times 8 \times 23 \\
&= 184\pi \text{ cm}^2
\end{aligned}$$

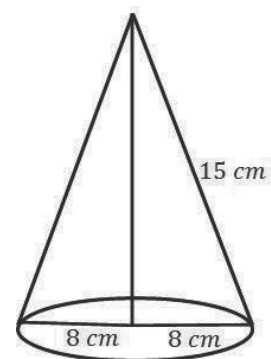

Practice

1. A sector is cut off from a circle radius 8.2 cm to form a cone. If the radius of the resulting cone is 3.5 cm, calculate the: a. curved surface area; b. total surface area of the cone. [Use $\pi = \frac{22}{7}$]

2. Find the curved surface area and angle at vertex of a cone of radius 3 cm and slant height 7 cm. [Use $\pi = \frac{22}{7}$]
3. A cone is made from a sector of a circle of radius 14 cm and angle of 90° . What is the curved surface area of the cone? [Use $\pi \frac{22}{7}$]
4. The curved surface area of a cone is 528 cm^2 . If the radius of the cone is 12 cm, find the slant height of the cone. [Use $\pi \frac{22}{7}$]
5. The total surface area of a cone is 484 cm^2 . If the slant height of the cone is 15 cm, find the radius of the cone. Give your answer to 2 significant figures. [Use $\pi \frac{22}{7}$]

Lesson Title: Volume of a cone	Theme: Mensuration
Lesson Number: PHM3-L040	Class: SSS 3
 Learning Outcome By the end of the lesson, you will be able to calculate the volume of a cone using the appropriate formula.	

Overview

We can find the volume of a cone by using the formula:

$$V = \frac{1}{3}\pi r^2 h$$

where r is the radius and h the height of the cone.

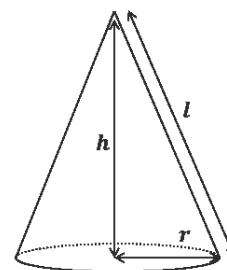

Solved Examples

- Find the volume of the cone shown if the base radius is 7 cm and height is 5 cm

Give your answer to 1 decimal place. Use $\pi = 3.142$

Solution:

Step 1. Assess and extract the given information from the problem.

Given: cone with radius $r = 7$ cm and height $h = 5$ cm

Step 2. Substitute into the appropriate formula.

$$\begin{aligned} \text{Volume, } V &= \frac{1}{3}\pi r^2 h \\ &= \frac{1}{3} \times 3.142 \times 7^2 \times 5 \\ V &= 256.597 \text{ cm}^3 \end{aligned}$$

Step 3. Write the answer.

The volume of the cone = 256.6 cm³ to 1 d.p.

- Find the volume of a cone of radius 3.5 cm and vertical height 12 cm. [Use $\pi = \frac{22}{7}$]

Solution:

$$\begin{aligned} \text{Volume} &= \frac{1}{3} \times \pi r^2 h \\ &= \frac{1}{3} \times \frac{22}{7} \times 3.5^2 \times 12 \\ &= \frac{3234}{21} \\ &= 154 \text{ cm}^2 \end{aligned}$$

- Find the volume of a cone of radius 4 cm and vertical height 6 cm. Give answer to 1 decimal place. [Use $\pi = 3.142$]

Solution:

$$\begin{aligned} \text{Volume} &= \frac{1}{3} \times \pi r^2 h \\ &= \frac{1}{3} \times 3.142 \times 4^2 \times 6 \\ &= \frac{301.632}{3} \\ &= 100.5 \text{ cm}^2 \end{aligned}$$

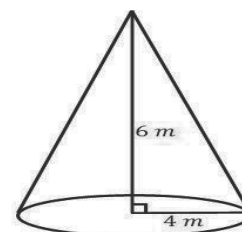
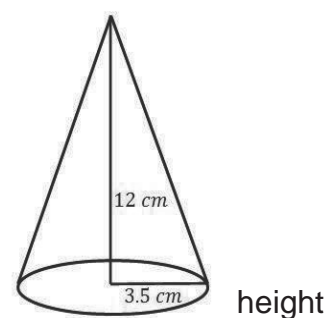

4. The volume of a cone of height 9 cm is $1,848 \text{ cm}^3$. Find its radius. [Use $\pi = \frac{22}{7}$]

Solution:

$$\begin{aligned} \text{Volume} &= \frac{1}{3} \times \pi r^2 h \\ 1,848 &= \frac{1}{3} \times \frac{22}{7} \times r^2 \times 9 \\ 1,848 &= \frac{198 \times r^2}{21} \\ 198r^2 &= 1,848 \times 21 \\ 198r^2 &= 38,808 \\ \frac{198r^2}{198} &= \frac{38,808}{198} \\ r^2 &= 196 \\ r &= \sqrt{196} \\ r &= 14 \text{ cm} \\ \text{radius} &= 14 \text{ cm} \end{aligned}$$

5. A sector of a circle of radius 10 cm with an angle of 135° is folded to form a cone. Find: a. the radius of the base circle of the cone; b. the height of the cone; c. the vertical angle; d. the volume of the cone [Use $\pi = 3.142$]

Solution:

$$\begin{aligned} r &= \frac{135^\circ \times 10}{360^\circ} \\ r &= 3.75 \text{ cm} \\ \text{a. base radius} &= 3.75 \text{ cm} \\ 10^2 &= h^2 + 3.75^2 \\ h^2 &= 10^2 - 3.75^2 \\ h^2 &= 85.9375 \\ h &= \sqrt{85.9375} \\ h &= 9.27 \text{ cm} \\ \text{b. height} &= 9.27 \text{ cm} \\ \sin \alpha &= \frac{3.75}{10} \\ \sin \alpha &= 0.375 \\ \alpha &= \sin^{-1} 0.375 \\ \alpha &= 22.02^\circ \\ \text{c. Angle at vertex} &= 2\alpha \\ &= 2 \times 22.02^\circ \\ &= 44^\circ \end{aligned}$$

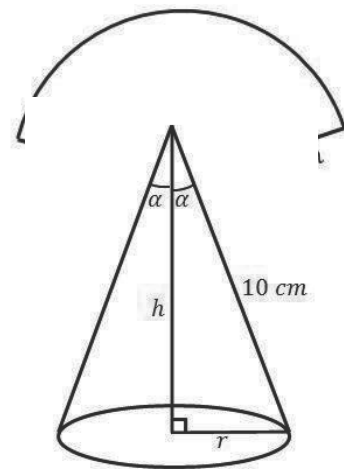

$$\begin{aligned}
 \text{d. Volume} &= \frac{1}{3} \times \pi r^2 h \\
 &= \frac{1}{3} \times 3.142 \times 3.75^2 \times 9.27 \\
 &= 136.53 \text{ cm}^2
 \end{aligned}$$

Practice

1. A cone is made from a sector of a circle of radius 7 cm and an angle of 210° . What is the volume of the cone? Give your answer to 3 significant figures. [Use $\pi = \frac{22}{7}$]
2. A sector of a circle of radius 12 cm with an angle of 140° is folded to form a cone. Find: a. the radius of the base circle of the cone; b. the height of the cone; c. the vertical angle; d. the volume of the cone. Give your answer to 2 significant figures. [Use $\pi = 3.142$]
3. The volume of a cone of height 14 cm is $3,300 \text{ cm}^3$. Find its radius. [Use $\pi = \frac{22}{7}$]
4. The volume of a cone of radius 6 cm is 792 cm^3 . Find its height. [Use $\pi = \frac{22}{7}$]
5. A cone is 14 cm deep and the base radius is $4\frac{1}{2}$ cm. Calculate the volume of water that is exactly half the volume of the cone. [Use $\pi = \frac{22}{7}$]

Lesson Title: Surface area of a rectangular pyramid	Theme: Mensuration
Lesson Number: PHM3-L041	Class: SSS 3
 Learning Outcome By the end of the lesson, you will be able to calculate the surface area of a rectangular pyramid using the appropriate formula.	

Overview

The diagrams show a rectangular pyramid and its net.

A pyramid is any solid object which has a polygon for its base, and triangular sides which meet at a point or apex.

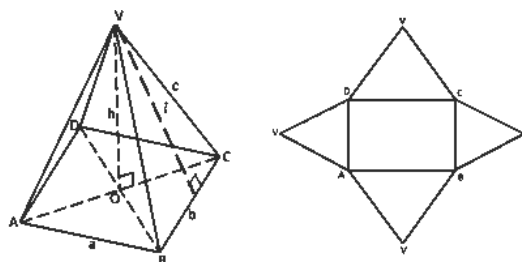

The type of polygon gives the pyramid its name. A pyramid with a base shaped as a triangle is called a triangular pyramid. If the base is a rectangle, it is called a rectangular pyramid.

A rectangular pyramid has 1 rectangular base and 4 triangular faces – one on each side of the base.

$$\begin{aligned}
 \text{surface area of rectangular pyramid} &= \text{area of the net} \\
 &= \text{area of rectangular base} + \text{area of triangular faces} \\
 &= \text{area of } ABCD + \text{area of } VDC + \text{area of } VAD + \text{area of } VBC + \text{area of } VAB
 \end{aligned}$$

$$\text{since } \Delta VDC = \Delta VAB \text{ and } \Delta VBC = \Delta VAD$$

$$\text{surface area of rectangular pyramid} = \text{area of } ABCD + 2 \times (\text{area of } VDC) + 2 \times (\text{area of } VBC)$$

For simplicity, most problems are based on a special rectangle with 4 equal sides – the square.

In a square, the slant height l of the pyramid is the same as the perpendicular height of the triangular faces. See the diagram at right.

$$\text{surface area of square pyramid} = \text{area of } ABCD + 4 \times (\text{area of } VBC)$$

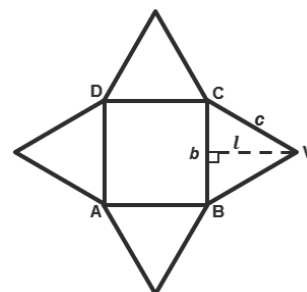

$$= b^2 + 4\left(\frac{1}{2} \times b \times l\right)$$

surface area of square pyramid = $b^2 + 2bl$

Solved Examples

1. Find the surface area of the square pyramid given below.

Solution:

Step 1. Assess and extract the given information from the problem.

Given: square pyramid of side length = 8 cm and slant height = 16 cm

Step 2. Use the net of the square pyramid to calculate the surface area.

$$\begin{aligned} \text{total surface area} &= \text{area of square base} \\ &+ \text{area of triangular faces} \end{aligned}$$

$$\begin{aligned} \text{area of square base} &= b^2 \\ &= 8^2 = 64 \text{ cm}^2 \end{aligned}$$

$$\begin{aligned} \text{area of triangular faces} &= 4\left(\frac{1}{2}bl\right) \\ &= 2bl \\ &= 2 \times 8 \times 16 = 256 \text{ cm}^2 \end{aligned}$$

where l the slant height of the pyramid = perpendicular height of the triangular faces

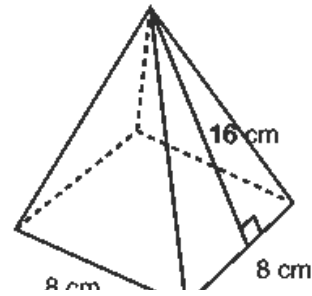

Step 3. Find the surface area of the pyramid.

$$\begin{aligned} \text{total surface area} &= b^2 + 2bl \\ &= 64 + 256 \\ &= 320 \text{ cm}^2 \end{aligned}$$

Step 4. Write the final answer.

The total surface area of the square pyramid is 320 cm².

2. The figure at right is a roof made of wooden beams which form a pyramid. The base is a rectangle, $ABCD$, where $AB = 15$ m and $BC = 10$ m. The vertex E is vertically above the midpoint, O , of the base. The triangle BEC makes an angle of 35° with the base.

Calculate: i. height of the pyramid; ii. the length of the beam EB ; iii. the total surface area of the pyramid. Give your answers to 3 significant figures.

Solution:

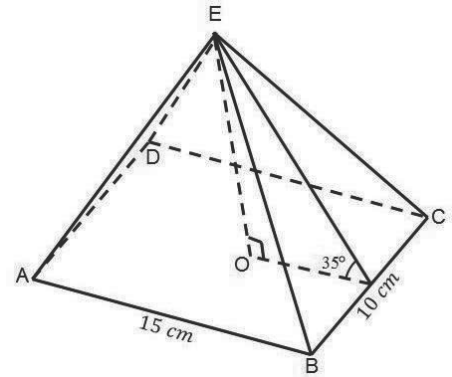

$$\begin{aligned}\tan 35^\circ &= \frac{OE}{7.5} \\ OE &= \tan 35^\circ \times 7.5 \\ OE &= 5.25 \text{ cm}\end{aligned}$$

i. Height of the pyramid = 5.25 cm

$$\begin{aligned}BD &= \sqrt{15^2 + 10^2} \\ &= 18.03 \text{ cm} \\ OB &= \frac{BD}{2} \\ &= \frac{18.03 \text{ cm}}{2} \\ &= 9.02 \text{ cm}\end{aligned}$$

$$\begin{aligned}\text{ii. } EB^2 &= OE^2 + OB^2 \\ &= 5.25^2 + 9.02^2 \\ &= \sqrt{108.9229} \\ EB &= 10.4 \text{ cm}\end{aligned}$$

From $\triangle EAB$, let x be the height

$$\begin{aligned}EB^2 &= x^2 + \frac{1}{2}AB^2 \\ 10.4^2 &= x^2 + 7.5 \\ x^2 &= 10.4^2 - 7.5^2 \\ &= 108.16 - 56.25 = 51.91 \\ x &= \sqrt{51.91} = 7.205 \\ &= 7.2 \text{ cm}\end{aligned}$$

$$\begin{aligned}\text{area of } \triangle EAB &= \frac{1}{2} \times 15 \times 7.2 \\ &= 54 \text{ cm}^2\end{aligned}$$

From $\triangle EBC$, let y be the height

$$EB^2 = y^2 + \frac{1}{2}BC^2$$

$$10.4^2 = y^2 + 5^2$$

$$y^2 = 10.4^2 - 5^2$$

$$= 108.16 - 25 = 83.16$$

$$y = \sqrt{83.16} = 9.119$$

$$= 9.1 \text{ cm}$$

$$\text{area of } \triangle EBC = \frac{1}{2} \times 10 \times 9.1$$

$$= 45.5 \text{ cm}^2$$

$$\text{iii. Total surface area} = \text{Area of } ABCD + 2(\text{Area of } \triangle EAB) + 2(\text{Area of } \triangle EBC)$$

$$= 15 \times 10 + 2(54) + 2(45.5)$$

$$= 150 + 108 + 91$$

$$\text{Total surface area} = 329 \text{ cm}^2$$

Practice

1. A solid right pyramid $OABCD$ has a square base $ABCD$ of side 8 cm and its slant faces slope at 65° to the base. Calculate: a. the height of the pyramid; b. the length of the slant edges; c. the total surface area of the pyramid. Give your answer to 1 decimal place.
2. A pyramid $UQRST$ with vertex U stands on a square base $QRST$. Each side of the base and all its sloping edges are 10cm. Calculate: a. the height of the pyramid; b. the angle between the planes URQ and $QRST$; c. the total surface area of the pyramid. Give your answer to 2 significant figures.

Lesson Title: Volume of a rectangular pyramid	Theme: Mensuration
Lesson Number: PHM3-L042	Class: SSS 3
 Learning Outcome By the end of the lesson, you will be able to calculate the volume of a rectangular pyramid using the appropriate formula.	

Overview

This lesson focuses on finding the volumes of rectangular pyramids. The formula for the volume of a rectangular pyramid is given by:

$$\begin{aligned}
 V &= \frac{1}{3} \times \text{area of base} \times \text{height} \\
 &= \frac{1}{3} lwh \quad \text{where } l \text{ is the length, } w \text{ the width and } h \text{ the height of the rectangular pyramid}
 \end{aligned}$$

Solved Examples

- Find the volume of the rectangular pyramid shown.

Solution:

Step 1. Assess and extract the given information from the problem.

Given: rectangular pyramid, length $l = 6$ cm, width $w = 4$ cm, height $h = 5$ cm

Step 2. Substitute into the appropriate formula.

$$\begin{aligned}
 \text{volume, } V &= \frac{1}{3} lwh \\
 &= \frac{1}{3} \times 6 \times 4 \times 5 \\
 V &= 40 \text{ cm}^3
 \end{aligned}$$

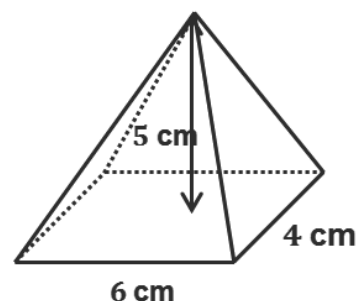

Step 3. Write the answer.

The volume of the rectangular pyramid = 40 cm^3 .

- A right pyramid is on a square base of side 4 cm. The slanting edge of the pyramid is $2\sqrt{3}$ cm. Calculate the volume of the pyramid.

Solution:

$$\begin{aligned}
 AC^2 &= 4^2 + 4^2 \\
 AC^2 &= 32 \\
 AC &= 4\sqrt{2} \text{ cm} \\
 AP &= \frac{AC}{2} \\
 AP &= 2\sqrt{2} \text{ cm} \\
 OC^2 &= AP^2 + OP^2
 \end{aligned}$$

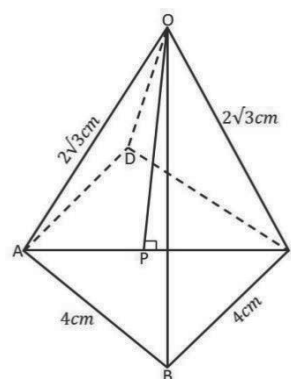

$$\begin{aligned}
(2\sqrt{3})^2 &= (2\sqrt{2})^2 + OP^2 \\
OP^2 &= (2\sqrt{3})^2 - (2\sqrt{2})^2 \\
OP^2 &= 4(3) - 4(2) \\
OP^2 &= 12 - 8 \\
OP^2 &= 4 \\
OP &= \sqrt{4} \\
OP &= 2 \\
\text{volume} &= \frac{1}{3} \times \text{base area} \times \text{height} \\
&= \frac{1}{3} \times 4 \times 4 \times 2 \\
&= \frac{32}{3} \\
&= 10.7 \text{ cm}^3
\end{aligned}$$

3. V is the vertex of a right pyramid on a square base. ABCD of side 16 cm. If the volume of the pyramid is 1,280 cm³, calculate:

- Its height
- The angle between the base ABCD and i. a sloping face; ii. a slant height of the pyramid, correct to three significant figures.

Solution:

$$\begin{aligned}
\text{volume} &= \frac{1}{3} \times l^2 \times h \\
1,280 &= \frac{1}{3} \times 16^2 \times h \\
&= \frac{256h}{3} \\
256h &= 1,280 \times 3 \\
\frac{256h}{256} &= \frac{1280 \times 3}{256} \\
h &= 15 \text{ cm}
\end{aligned}$$

a. *height* = 15 cm

α = angle between the base and a sloping face

$$\begin{aligned}
\text{b. i. } \tan \alpha &= \frac{15}{8} \\
\tan \alpha &= 1.85 \\
\alpha &= \tan^{-1} 1.875 \\
&= 61.9^\circ \\
AC^2 &= 16^2 + 16^2 \\
&= 512 \\
AC &= \sqrt{512} \\
AC &= 22.63 \\
AT &= \frac{AC}{2}
\end{aligned}$$

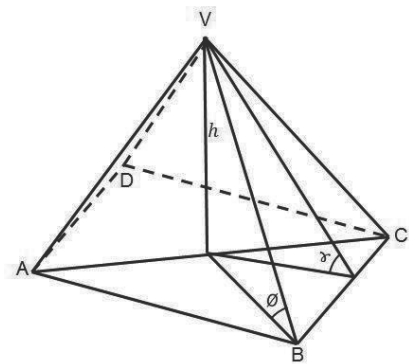

$$= \frac{22.63}{2}$$

$$AT = 11.3 \text{ cm}$$

θ = angle between the base and a slant height.

$$\text{b. ii. } \tan \theta = \frac{15}{11.3}$$

$$\tan \theta = 1.327$$

$$\theta = \tan^{-1} 1.327$$

$$\theta = 53^\circ$$

Practice

1. The height of a pyramid on a square base is 15 cm. If the volume is 80 cm^3 , find the length of the side of the base.
2. A solid pyramid with vertex O has a square base. The volume of the pyramid is $5,292 \text{ cm}^3$ and its height is 27 cm. Calculate: a. The length of a side of the base; b. The slant height, correct to one decimal place; c. The area of the sloping faces, correct to one decimal place.

Lesson Title: Surface area of a triangular pyramid	Theme: Mensuration
Lesson Number: PHM3-L043	Class: SSS 3
 Learning Outcome By the end of the lesson, you will be able to calculate the surface area of a triangular pyramid using the appropriate formula.	

Overview

A triangular pyramid has a triangle as its base. It is also called a tetrahedron.

A triangular pyramid has got 4 triangular faces – the base of the pyramid plus one on each side of the base.

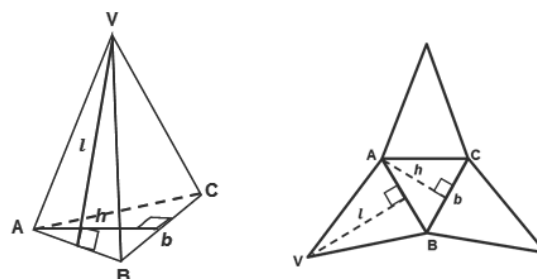

$$\begin{aligned}
 \text{surface area of triangular pyramid} &= \text{area of the net} \\
 &= \text{area of triangular base} + \text{area of triangular faces} \\
 &= \text{area of } ABC + \text{area of } VAB + \text{area of } VBC + \text{area of } VAC
 \end{aligned}$$

$$\text{since } \Delta VAB = \Delta VBC = \Delta VAC$$

$$\text{surface area of triangular pyramid} = \text{area of } ABC + 3 \times (\text{area of } VAB)$$

For simplicity, most problems are based on an equilateral triangle as the base and either isosceles or equilateral triangles as the other faces of the pyramid.

$$\text{surface area of triangular pyramid} = \frac{1}{2} \times b \times h + (3 \times \frac{1}{2} \times b \times l)$$

$$\begin{aligned}
 \text{surface area of triangular pyramid} &= \frac{1}{2}bh + \frac{3}{2}bl \\
 &= \frac{1}{2}b(h + 3l)
 \end{aligned}$$

If the triangular faces and the base are congruent equilateral triangles, the pyramid is called a regular tetrahedron.

For regular tetrahedrons, the slant height l of the pyramid is the same as the perpendicular height of the triangular faces.

Solved Examples

- Find the total surface area of the triangular pyramid given below. Give the answer to the nearest whole number.

Solution:

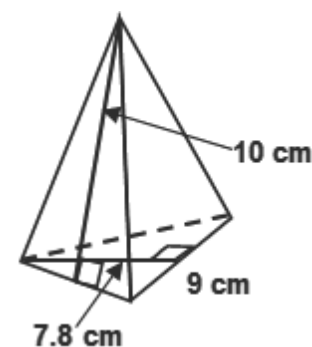

Step 1. Assess and extract the given information from the problem.

Given: triangular pyramid with base $b = 9$ cm, base height $h = 7.8$ cm and height of the triangular faces $l = 10$ cm

Step 2. Use the net of the triangular pyramid to calculate the surface area.

$$\begin{aligned} \text{total surface area} &= \text{area of triangular base} \\ &+ \text{area of 3 triangular faces} \\ &= \frac{1}{2}b(h + 3l) \quad \begin{array}{l} \text{base height} = h, \\ \text{triangular faces height} = l \end{array} \end{aligned}$$

Step 3. Find the surface area of the pyramid.

$$\begin{aligned} \text{total surface area} &= \frac{1}{2} \times 9 \times (7.8 + (3 \times 10)) \quad \begin{array}{l} \text{substitute } b = 9 \text{ cm} \\ h = 7.8 \text{ cm}, l = 10 \text{ cm} \end{array} \\ &= \frac{1}{2} \times 9 \times 37.8 \\ &= 170.1 \text{ cm}^2 \end{aligned}$$

Step 4. Write the final answer.

The total surface area of the triangular pyramid is 170 cm² to the nearest whole number.

2. Pyramid ABCD, whose base BCD is an equilateral triangle of side 8 cm, has its slant edges AB, AC and AD each with a length of 10 cm. The foot of the perpendicular from A to the base BCD is M. Calculate: a. |BM| b. |AM| c. The surface area of the pyramid.

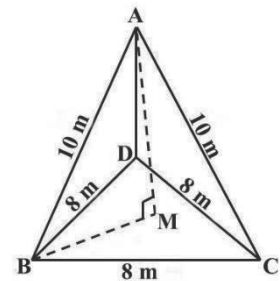

Solution:

$$\begin{aligned} &\text{From } \triangle BCD \\ \triangle BMD &= \triangle BMC = \triangle CMD && \text{Symmetry} \\ &\text{From } \triangle BMC \\ \frac{8}{\sin 120^\circ} &= \frac{BM}{\sin 30^\circ} \\ BM &= \frac{8 \times \sin 30^\circ}{\sin 120^\circ} \\ BM &= 4.62 \text{ m} \end{aligned}$$

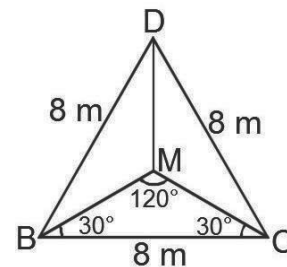

$$\begin{aligned} &\text{From } \triangle ABM \\ AM^2 &= AB^2 - BM^2 \\ &= 10^2 - (4.62)^2 \\ &= 78.6556 \\ AM &= \sqrt{78.6556} \\ AM &= 8.87 \text{ m} \end{aligned}$$

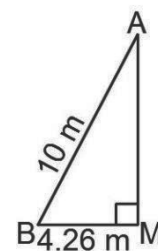

From $\triangle BCD$

DT = perpendicular height

$BT = CT = 4\text{m}$

From $\triangle DTC$ and using Pythagoras theorem

$$DC^2 = DT^2 + TC^2$$

$$8^2 = DT^2 + 4^2$$

$$64 = DT^2 + 16$$

$$DT^2 = 64 - 16$$

$$= 48$$

$$DT = \sqrt{48}$$

$$= 6.93\text{ m}$$

$$\begin{aligned} \text{Area of } \triangle BDC &= \frac{1}{2} \times BC \times DT \\ &= \frac{1}{2} \times 8 \times 6.93 \\ &= 27.72\text{ m}^2 \end{aligned}$$

From $\triangle ABD$

AK = perpendicular height

$BK = DK = 4\text{m}$

From $\triangle AKD$

$$AD^2 = AK^2 + KD^2$$

$$10^2 = AK^2 + 4^2$$

$$100 = AK^2 + 16$$

$$AK^2 = 100 - 16$$

$$= 84$$

$$AK = \sqrt{84}$$

$$AK = 9.17\text{ m}$$

$$\begin{aligned} \text{Area of } \triangle BDC &= \frac{1}{2} \times BD \times AK \\ &= \frac{1}{2} \times 8 \times 9.17 \\ &= 36.68\text{ m}^2 \end{aligned}$$

$$\begin{aligned} \text{Surface area} &= \text{Area of base BDC} + 3(\text{Area of } \triangle ABC) \\ &= 27.72 + 3(36.68) \\ &= 27.72 + 110.04 \\ &= 137.76\text{ m}^2 \end{aligned}$$

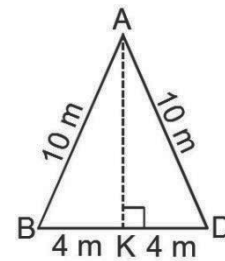
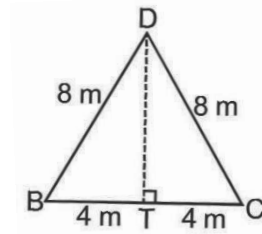

Practice

- Pyramid PQRS, whose base QRS is an equilateral triangle with sides of 12 cm, has slant edges PQ, PR and PS each with a length of 15 cm. The foot of the perpendicular from P to the base QRS is T. Calculate:
 - $|QT|$; b. $|PT|$ c. The surface area of the pyramid.

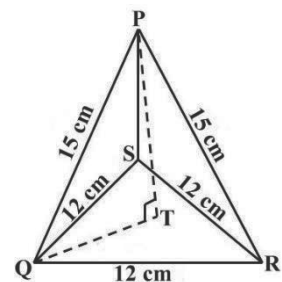

2. PQRV is a right pyramid with base PQR which is an equilateral triangle with sides of 14 cm. Each sloping edge of the pyramid is a length of 10 cm. G is the centre of symmetry the $\triangle PQR$. Given that $|PG| = 8.1$ cm. Calculate:
- The height of the pyramid correct to one decimal.
 - The surface area of the pyramid to the nearest whole number.

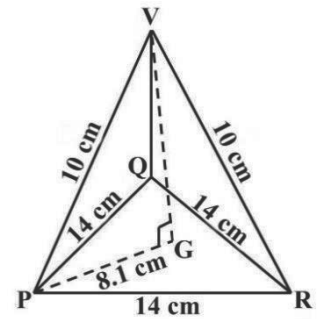

3. The height of a right pyramid on an equilateral triangular base is 7.8 cm. If the length of a side of the base is 18 cm, find the surface area of the pyramid. Give your answer to the nearest whole number.

Lesson Title: Volume of a triangular pyramid	Theme: Mensuration
Practice Activity: PHM3-L044	Class: SSS 3
 Learning Outcome By the end of the lesson, you will be able to calculate the volume of a triangular pyramid using the appropriate formula.	

Overview

The formula for the volume of a triangular pyramid is given by:

$$\begin{aligned}
 V &= \frac{1}{3} \times \text{area of base} \times \text{height} && (1) \\
 &= \frac{1}{3} \times \frac{1}{2}bh \times H && \text{where } b \text{ is the side length of the base, } h \text{ the base height and } H \text{ the height of the triangular pyramid} \\
 &= \frac{1}{6}bhH && \text{[NOTE: It is advisable to use (1) to find the volume of the pyramid]}
 \end{aligned}$$

Solved Examples

- Find the total surface area of the triangular pyramid below. Give answers to the nearest whole number.

Solution:

Step 1. Assess and extract the given information from the problem.

Given: triangular pyramid, base length $b = 12$ cm, base height $h = 10$ cm, height of pyramid $H = 14$ cm

Step 2. Substitute into the appropriate formula.

$$\begin{aligned}
 \text{volume, } V &= \frac{1}{3} \times \text{area of base} \times \text{height} \\
 \text{area of base} &= \frac{1}{2}bh \\
 &= \frac{1}{2} \times 12 \times 10 \\
 \text{area of base} &= 60 \text{ cm}^2 \\
 \text{volume of pyramid} &= \frac{1}{3} \times 60 \times 14 \\
 &= 280 \text{ cm}^3
 \end{aligned}$$

Step 3. Write the answer.

The volume of the triangular pyramid = 280 cm^3 .

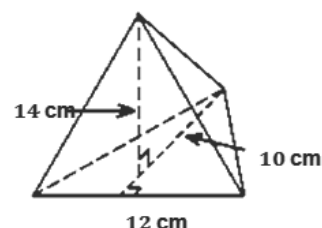

- A pyramid ABCD, whose base BCD is an equilateral triangle with sides of 8 m, has its slant edges AB, AC and AD each with a length of 10 m. The foot of the perpendicular from A to the base BCD is M. Calculate: a |BM|; b. |AM|; c. The volume of the pyramid.

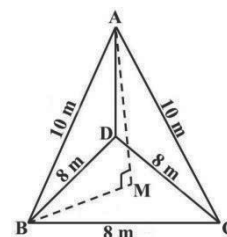

Solution:

From $\triangle BCD$
 $\triangle BMD = \triangle BMC = \triangle CMD$ Symmetry

From $\triangle BMC$

$$\frac{8}{\sin 120^\circ} = \frac{BM}{\sin 30^\circ}$$

$$BM = \frac{8 \times \sin 30^\circ}{\sin 120^\circ}$$

$$BM = 4.62 \text{ m}$$

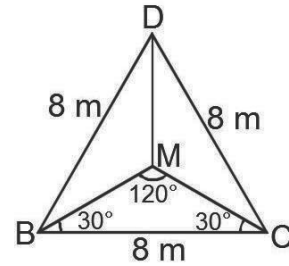

From $\triangle ABM$

$$AM^2 = AB^2 - BM^2$$

$$= 10^2 - (4.62)^2$$

$$= 78.6556$$

$$AM = \sqrt{78.6556}$$

$$AM = 8.87 \text{ m}$$

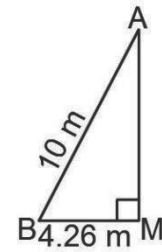

From $\triangle BCD$

DT = perpendicular height

BT = CT = 4 m

From $\triangle DTC$ and using Pythagoras theorem

$$DC^2 = DT^2 + TC^2$$

$$8^2 = DT^2 + 4^2$$

$$64 = DT^2 + 16$$

$$DT^2 = 64 - 16$$

$$= 48$$

$$DT = \sqrt{48}$$

$$= 6.93 \text{ m}$$

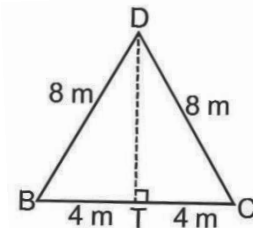

$$\text{Area of } \triangle BDC = \frac{1}{2} \times BC \times DT$$

$$= \frac{1}{2} \times 8 \times 6.93$$

$$= 27.72 \text{ m}^2$$

$$\text{Volume} = \frac{1}{3} \times \text{base area} \times \text{height}$$

$$= \frac{1}{3} \times 27.72 \times 8.87$$

$$= 81.96 \text{ cm}^3$$

Practice

1. A pyramid PQRS, whose base QRS is an equilateral triangle with sides of 12 cm, and slant edges PQ, PR and PS each with a length of 15 cm. The foot of the perpendicular from P to the base QRS is T. Calculate:

- a. |QT|; b. |PT|; c. The volume of the pyramid.

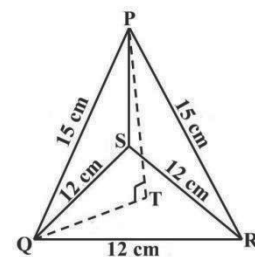

2. A regular tetrahedron has a total surface area of 600 cm^2 . If the perpendicular height of the base is 16 cm, find: a. The length of its sides; b. The volume of the tetrahedron if the height of the pyramid is 15 cm.

3. The height of a right pyramid on an equilateral triangular base is 7.8 cm. If the length of a side of the base is 18 cm, find the volume of the pyramid. Give your answer to the nearest whole number.

Lesson Title: Surface area of a sphere	Theme: Mensuration
Lesson Number: PHM3-L045	Class: SSS 3
 Learning Outcome By the end of the lesson, you will be able to calculate the surface area of a sphere using the appropriate formula.	

Overview

The formula for the surface area of a sphere is given by:

$$A = 4\pi r^2$$

where r is the radius of the sphere.

Many problems require us to calculate the surface area of the hemisphere which is half of a sphere.

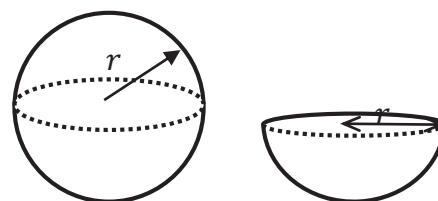

The formula for the surface area of a hemisphere is:

$$A = 2\pi r^2$$

When the hemisphere has a base, its surface area is given by:

$$A = 2\pi r^2 + \pi r^2 = 3\pi r^2$$

Solved Examples

- Find the surface area of the given sphere with $r = 7.5$ cm.
Give your answers to 3 significant figures.

Solution:

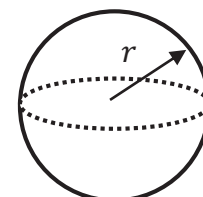

Step 1. Assess and extract the given information from the problem.

Given sphere of radius = 7.5 cm

Step 2. Substitute into the appropriate formula.

$$\begin{aligned} \text{surface area} &= 4\pi r^2 \\ &= 4 \times 3.142 \times 7.5^2 \\ &= 706.95 \end{aligned}$$

Step 3. Write the answer.

The surface area of the sphere is 707 cm² to 3 s.f.

- Calculate the surface area of a sphere of radius 14 cm. Use $\pi = \frac{22}{7}$.

Solution:

$$\begin{aligned}
\text{Surface area} &= 4\pi r^2 \\
&= 4 \times \frac{22}{7} \times 14^2 \\
&= \frac{17,248}{7} \\
&= 2,464 \text{ cm}^2
\end{aligned}$$

3. Ten identical spheres of radius 7 cm are to be painted. What is the total area of surface to be painted?

Solution:

$$\begin{aligned}
\text{Surface area of 1 sphere} &= 4\pi r^2 \\
&= 4 \times \frac{22}{7} \times 7^2 \\
&= \frac{4,312}{7} \\
&= 616 \text{ cm}^2
\end{aligned}$$

$$\begin{aligned}
\text{Surface area of 10 spheres} &= 10 \times 616 \text{ cm}^2 \\
&= 6,160 \text{ cm}^2
\end{aligned}$$

4. Find the surface area of each of the spheres with diameters given below:
a. 3.5 cm

Solution:

$$\begin{aligned}
r &= \frac{3.5}{2} \\
r &= 1.75 \text{ cm}
\end{aligned}$$

$$\begin{aligned}
\text{Surface area of sphere} &= 4\pi r^2 \\
&= 4 \times \frac{22}{7} \times 1.75^2 \\
&= \frac{269.5}{7} \\
&= 38.5 \text{ cm}^2
\end{aligned}$$

- b. 42 cm

Solution:

$$\begin{aligned}
r &= \frac{42}{2} \\
r &= 21 \text{ cm}
\end{aligned}$$

$$\begin{aligned}
\text{Surface area of sphere} &= 4\pi r^2 \\
&= 4 \times \frac{22}{7} \times 21^2 \\
&= \frac{38,808}{7} \\
&= 5,544 \text{ cm}^2
\end{aligned}$$

5. Find the radius of each of the spheres whose surface area is:
a. 24.64 cm^2

Solution:

$$\begin{aligned}\text{Surface area of sphere} &= 4\pi r^2 \\ 24.64 &= 4 \times 3.142 \times r^2 \\ 24.64 &= 12.568 \times r^2 \\ r^2 &= \frac{24.64}{12.568} \\ r^2 &= 1.96 \\ r &= \sqrt{1.96} \\ r &= 1.4 \text{ cm}\end{aligned}$$

b. 394.24 cm^2

Solution:

$$\begin{aligned}\text{Surface area of sphere} &= 4\pi r^2 \\ 394.24 &= 4 \times 3.142 \times r^2 \\ 394.24 &= 12.568 \times r^2 \\ r^2 &= \frac{394.24}{12.568} \\ r^2 &= 31.37 \\ r &= \sqrt{31.37} \\ r &= 5.6 \text{ cm}\end{aligned}$$

Practice

- Find the surface area of each of the spheres with diameter given below:
a. 21 cm b. 30 cm c. 6.3 cm
- Find the radius of each of the spheres whose surface areas are:
a. 887.04 cm^2 b. 444.4 cm^2
- 28 identical wooden household decorations in the form of spheres with a radius of 12 cm are to be polished by a carpenter. What is the total surface area to be polished to the nearest whole number?

Lesson Title: Volume of a sphere	Theme: Mensuration
Lesson Number: PHM3-L046	Class: SSS 3
 Learning Outcome By the end of the lesson, you will be able to calculate the volume of a sphere using the appropriate formula.	

Overview

The formula for the volume of a sphere is given by:

$$V = \frac{4}{3}\pi r^3$$

where r is the radius of the sphere.

The volume of a hemisphere is half that of the sphere.

The formula for the volume of a hemisphere is:

$$V = \frac{1}{2} \times \frac{4}{3}\pi r^3 = \frac{2}{3}\pi r^3$$

Solved Examples

1. Find the volume of the given sphere with $r = 3.5$ cm.
2. Give all answers to 1 decimal place unless otherwise stated.
3. Use $\pi = 3.142$ unless otherwise stated.

Solution:

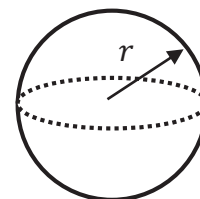

Step 1. Assess and extract the given information from the problem.

Given: sphere with radius $r = 3.5$ cm

Step 2. Substitute into the appropriate formula.

$$\begin{aligned} \text{Volume, } V &= \frac{4}{3}\pi r^3 \\ &= \frac{4}{3} \times 3.142 \times 3.5^3 \\ V &= 179.59 \text{ cm}^3 \end{aligned}$$

Step 3. Write the answer.

The volume of the sphere = 179.6 cm^3 to 1 d.p.

4. A sphere of radius r cm has the same volume as a cylinder of radius 6 cm and height 8 cm. Find the value of r .

Solution:

$$\text{Volume of sphere} = \text{Volume of cylinder}$$

$$\frac{4}{3} \times \pi r^3 = \pi r^2 h$$

$$\frac{4}{3} \times \pi \times r^3 = \pi \times 6^2 \times 8$$

$$\frac{4r^3}{3} = 288$$

$$r^3 = \frac{288 \times 3}{4}$$

$$r^3 = 216$$

$$r = \sqrt[3]{216}$$

$$r = 6$$

5. A hollow sphere was completely filled with 2 litres of water. Calculate the internal radius of the sphere in cm. Use $\pi = 3.142$.

Solution:

$$\text{Volume of sphere} = \frac{4}{3} \times \pi r^3$$

$$2,000 \text{ cm}^3 = \frac{4}{3} \times 3.142 \times r^3$$

$$2,000 = \frac{12.568r^3}{3}$$

$$r^3 = \frac{6,000}{12.568}$$

$$r^3 = 477.40$$

$$r = \sqrt[3]{477.40}$$

$$r = 7.82 \text{ cm}$$

6. Find the radius of each of the spheres whose volume is:

a. $38,808 \text{ cm}^3$

b. $24,438.86 \text{ cm}^3$

Solution:

$$\text{Volume of sphere} = \frac{4}{3} \times \pi r^3$$

$$38,808 = \frac{4}{3} \times 3.142 \times r^3$$

$$38,808 = \frac{12.568r^3}{3}$$

$$12.568r^3 = 116,424$$

$$r^3 = \frac{116,424}{12.568}$$

$$r^3 = 9,263.53$$

$$r = \sqrt[3]{9,263.53}$$

$$r = 21 \text{ cm}$$

Solution:

$$\text{Volume of sphere} = \frac{4}{3} \times \pi r^3$$

$$24,438.86 = \frac{4}{3} \times 3.142 \times r^3$$

$$24,438.86 = \frac{12.568r^3}{3}$$

$$12.568r^3 = 73,316.58$$

$$r^3 = \frac{73,316.58}{12.568}$$

$$r^3 = 5,833.59$$

$$r = \sqrt[3]{5,833.59}$$

$$r = 18 \text{ cm}$$

7. Find the volume of each of the spheres whose radius is:

a. 7 cm

b. 24 cm

Solution:

$$\begin{aligned}\text{Volume of sphere} &= \frac{4}{3} \times \pi r^3 \\ &= \frac{4}{3} \times 3.142 \times 7^3 \\ &= \frac{4,310.824}{3} \\ &= 1,436.94 \text{ cm}^3\end{aligned}$$

Solution:

$$\begin{aligned}\text{Volume of sphere} &= \frac{4}{3} \times \pi r^3 \\ &= \frac{4}{3} \times 3.142 \times 24^3 \\ &= \frac{173,740.032}{3} \\ &= 57,913.34 \text{ cm}^3\end{aligned}$$

Practice

1. A sphere of radius r cm has the same volume as a cylinder of radius 3 cm and height 12 cm. Find the value of r .
2. A hollow sphere was completely filled with 500 cm^3 of water. Calculate the internal radius of the sphere. Take $\pi=3.142$.
3. Find correct to 2 significant figures the volume of each of the spheres whose radius is:
a. 3.5 cm b. 42 cm c. 6.3 cm
4. Find the radius of each of the spheres whose volume is:
a. $7,241.14 \text{ cm}^3$ b. $1,437.33 \text{ cm}^3$

Lesson Title: Surface area of composite solids	Theme: Mensuration
Lesson Number: PHM3-L047	Class: SSS 3
 Learning Outcome By the end of the lesson, you will be able to calculate the surface area of composite solids using the appropriate formulae.	

Overview

To find the surface area of a composite solid, first identify the solids it is made up of. Find the individual surface area using the appropriate formula. Finally, add the surface areas together.

Solved Examples

- Find the surface area of the composite shapes shown. . Assume all closed shapes except otherwise stated. Give answers to the nearest cm^2 . Use $\pi = 3.142$

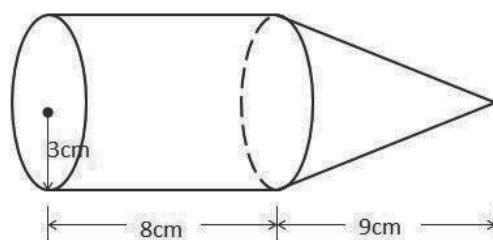

Solution:

Step 1. Assess and extract the given information from the problem.

given: composite solid made from a cylinder and a cone

Step 2. Identify and divide the shape into its individual parts

a cylinder and a cone

height of cone $h = 9$ cm; height of cylinder $H = 8$ cm; $r = 3$ cm

Step 3. Find the individual surface area for each solid.

$$\begin{array}{l} \text{surface area} \\ \text{of solid} \end{array} = \text{surface area of cone} + \text{surface area of cylinder}$$

$$\begin{aligned} \text{surface area of cone} &= \pi r^2 + \pi r l \\ &= \pi(r^2 + r l) \end{aligned}$$

$$\begin{aligned} \text{Find } l \quad l^2 &= h^2 + r^2 \\ &= 9^2 + 3^2 \\ &= 81 + 9 \\ &= 90 \\ &= \sqrt{90} \end{aligned}$$

$$l = 9.487 \text{ cm}$$

$$\begin{aligned} \text{surface area of cone} &= 3.142(3^2 + (3 \times 9.487)) \\ &= 117.702 \text{ cm}^2 \end{aligned}$$

$$\begin{aligned}
 \text{surface area of cylinder} &= 2\pi r(r + h) \\
 &= 2 \times 3.142 \times 3 \times (3 + 8) \\
 &= 207.372 \text{ cm}^2
 \end{aligned}$$

Step 4. Find the sum of the surface areas of the cone and cylinder

$$\begin{aligned}
 \text{surface area of solid} &= 117.702 + 207.372 \\
 &= 325.074 \text{ cm}^2
 \end{aligned}$$

Step 5. Write the final answer.

The surface area of the solid is 325 cm² to the nearest cm².

2. The solid shown is a cylinder surmounted by a hemispherical bowl. Calculate its total surface area. [Use $\pi = \frac{22}{7}$].

Solution:

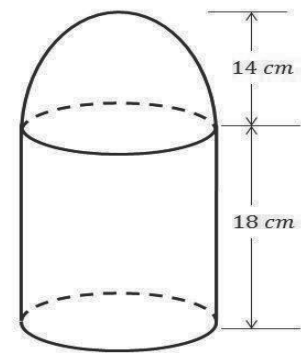

$$\begin{aligned}
 \text{Hemisphere} &= \frac{1}{2} \text{ of a sphere} \\
 \text{Curved surface area of hemisphere} &= 2\pi r^2 \\
 &= 2 \times \frac{22}{7} \times 14^2 \\
 &= 1,232 \text{ cm}^2 \\
 \text{Curved surface area of cylinder} &= 2\pi rh \\
 &= 2 \times \frac{22}{7} \times 14 \times 18 \\
 &= 1,584 \text{ cm}^2 \\
 \text{Total surface area of sol} &= \text{Curved surface area of hemisphere} + \text{Curved surface area of cylinder} \\
 &= 1,232 \text{ cm}^2 + 1,584 \text{ cm}^2 \\
 &= 2,816 \text{ cm}^2
 \end{aligned}$$

3. The model in the figure is made up of a cylinder and a cone. The height of the cylinder is 29 cm and the height of the cone is 19 cm. Calculate the total surface area of the model. Give your answer to 2 decimal places.

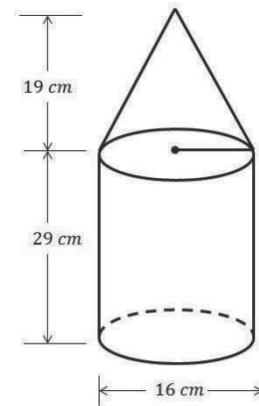

Solution:

$$l^2 = 19^2 + 8^2$$

$$l^2 = 425$$

$$l = \sqrt{425}$$

$$l = 20.62 \text{ cm}$$

$$\begin{aligned} \text{Total surface area of cone} &= \pi r(r + l) \end{aligned}$$

$$= \frac{22}{7} \times 8(8 + 20.62)$$

$$= \frac{22}{7} \times 8 \times 28.62$$

$$= 719.59 \text{ cm}^2$$

$$\begin{aligned} \text{Total surface area of cylinder} &= 2\pi rh \end{aligned}$$

$$= 2 \times \frac{22}{7} \times 8 \times 29$$

$$= 1,458.29 \text{ cm}^2$$

$$\begin{aligned} \text{Total surface area of the model} &= \text{Total surface area of cone} + \\ &\quad \text{Total surface area of cylinder} \end{aligned}$$

$$= 719.59 \text{ cm}^2 + 1458.29 \text{ cm}^2$$

$$= 2,177.88 \text{ cm}^2$$

Practice

- The solid at right is a cylinder surmounted by a hemispherical bowl. Calculate its total surface area. [Take $\pi = \frac{22}{7}$]
- The diagram at right shows a hut made of a conical roof and a cylindrical wall. The height of the roof is 4 m and its base is 3.5 m. The cylindrical wall has a height of 4.5 m and base area of 78.55 m^2 .
 - Calculate, correct to three significant figures,
 - The slant height of the conical roof
 - The surface area of the conical roof
 - The external surface area of the wall

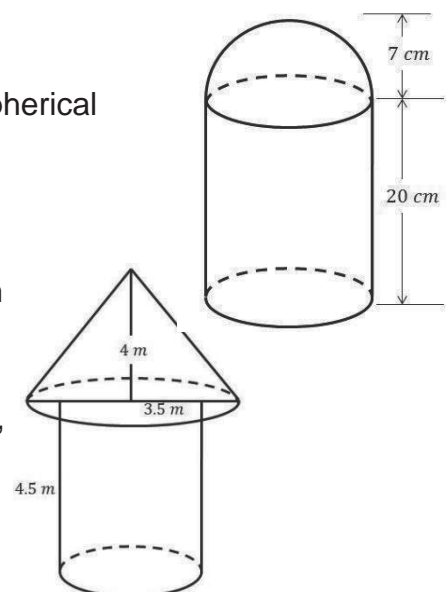

- b. If the cost of painting a square metre of surface is Le 500.00, calculate the total cost of painting the outer area of the wall and the roof of the hut.
[Take $\pi = 3.142$]

3. The model in the figure below is made up of a cylinder and a cone. The height of the cylinder is 12 cm and the height of the cone is 6 cm. Calculate the total surface area of the model.
Give your answer to 2 decimal places. [Take $\pi = \frac{22}{7}$]

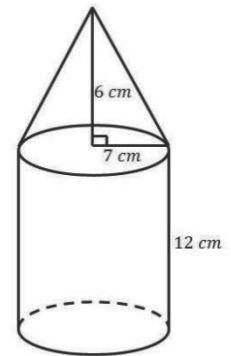

Lesson Title: Volume of composite solids	Theme: Mensuration
Lesson Number: PHM3-L048	Class: SSS 3
 Learning Outcome By the end of the lesson, you will be able to calculate the volume of composite solids using the appropriate formulae.	

Overview

To find the volume of a composite solid, first identify the solids it is made up of. Find the individual volume using the appropriate formula. Finally, add the volumes together.

Solved Examples

- Find the volume of the composite shapes shown. Assume all closed shapes except otherwise stated. Give answers to the nearest cm^3 .

Solution:

Step 1. Assess and extract the given information from the problem.

Given: composite solid made from 2 cuboids with given lengths, widths and heights

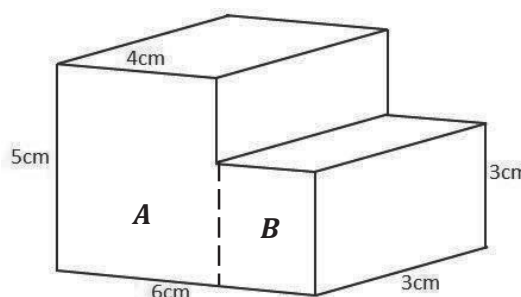

Step 2. Identify and divide the shape into its individual parts.

Label the shape A and B – see diagram.

Step 3. Find the individual volume for each cuboid.

$$\text{Volume of solid} = \text{volume of A} + \text{volume of B}$$

$$\begin{aligned} \text{Volume of A} &= (l \times w \times h)_A & l = 4 \text{ cm}, w = 3 \text{ cm}, h = 5 \text{ cm} \\ &= 4 \times 3 \times 5 \\ &= 60 \text{ cm}^3 \end{aligned}$$

$$\begin{aligned} \text{Volume of B} &= (l \times w \times h)_B & l = 2 \text{ cm}, w = 3 \text{ cm}, h = 3 \text{ cm} \\ &= 2 \times 3 \times 3 \\ &= 18 \text{ cm}^3 \end{aligned}$$

Step 4. Find the sum of the volume of the cuboids.

$$\text{Volume of solid} = 60 + 18$$

$$\text{Volume of solid} = 78 \text{ cm}^3$$

Step 5. Write the final answer.

The volume of the solid is 78 cm^3 .

2. A plastic marker buoy floating in the sea consists of a cone attached to a hemispherical base as shown. The radius of the hemispherical base is 0.95 m and the height of the cone is 1.2 m. Calculate the volume of the buoy. [Use $\pi = 3.142$]

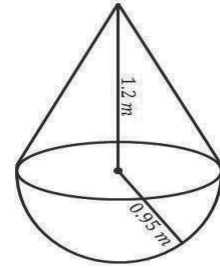

Solution:

$$\begin{aligned}
 \text{Volume of cone} &= \frac{1}{3}\pi r^2 h \\
 &= \frac{1}{3} \times 3.142 \times (0.95)^2 \times 1.2 \\
 &= 1.13 \text{ m}^3 \\
 \text{Volume of hemisphere} &= \frac{2}{3}\pi r^3 \\
 &= \frac{2}{3} \times 3.142 \times (0.95)^3 \\
 &= 1.80 \text{ m}^3 \\
 \text{Volume of model} &= \text{Volume of cone} + \\
 &\quad \text{Volume of hemisphere} \\
 &= 1.13 \text{ cm}^3 + 1.80 \text{ cm}^3 \\
 &= 2.93 \text{ m}^3
 \end{aligned}$$

3. The solid shown is a cylinder surmounted by a hemispherical bowl. Calculate its total surface area. [Use $\pi = \frac{22}{7}$]

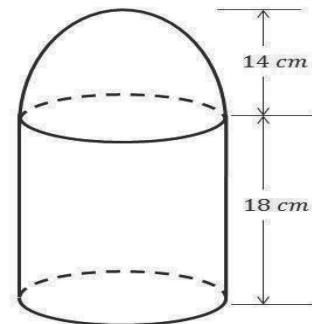

Solution:

$$\begin{aligned}
 \text{Hemisphere} &= \frac{1}{2} \text{ of a sphere} \\
 \text{Volume of hemisphere} &= \frac{2}{3}\pi r^3 \\
 &= \frac{2}{3} \times \frac{22}{7} \times 14^3 \\
 &= 5,749.33 \text{ cm}^3 \\
 \text{Volume of cylinder} &= \pi \times r^2 \times h \\
 &= \frac{22}{7} \times 14^2 \times 18 \\
 &= 11,088 \text{ cm}^3 \\
 \text{Volume} &= \text{Volume of hemisphere} + \text{Volume of cylinder} \\
 &= 5,749.33 \text{ cm}^3 + 11,088 \text{ cm}^3 \\
 &= 16,837.33 \text{ cm}^3
 \end{aligned}$$

4. The model in the figure below is made up of a cylinder and a cone. The height of the cylinder is 29 cm and the height of the cone is 19 cm. Calculate the volume of the model. Give your answer to 2 decimal places.

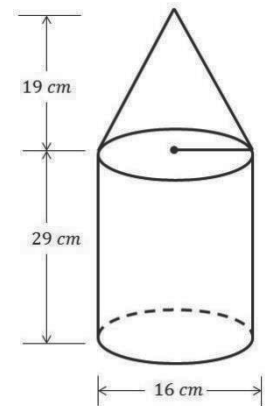

Solution:

$$\begin{aligned}
 \text{Volume of cone} &= \frac{1}{3} \times \pi \times r^2 \times h \\
 &= \frac{1}{3} \times \frac{22}{7} \times 8^2 \times 19 \\
 &= 1,273.90 \text{ cm}^3 \\
 \text{Volume of cylinder} &= \pi \times r^2 \times h \\
 &= \frac{22}{7} \times 8^2 \times 29 \\
 &= 5,833.14 \text{ cm}^3 \\
 \text{Volume of model} &= \text{Volume of cone} + \text{Volume of cylinder} \\
 &= 1,273.90 \text{ cm}^3 + 5,833.14 \text{ cm}^3 \\
 &= 7,107.04 \text{ cm}^3
 \end{aligned}$$

Practice

1. The solid shown at right is a cylinder surmounted by a hemispherical bowl. Calculate its volume to the nearest whole number. [Take $\pi = \frac{22}{7}$]

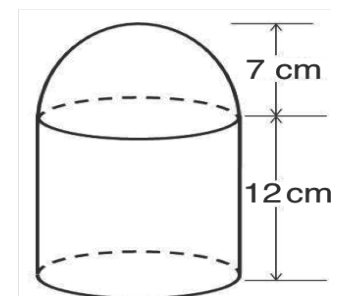

2. The diagram at right shows a fuel tank. The top part is a cylinder with diameter 21 cm and height 24 cm. the lower part is cone of height 9 cm. calculate to the nearest whole number, the volume of the tank. [Take $\pi = 3.142$]

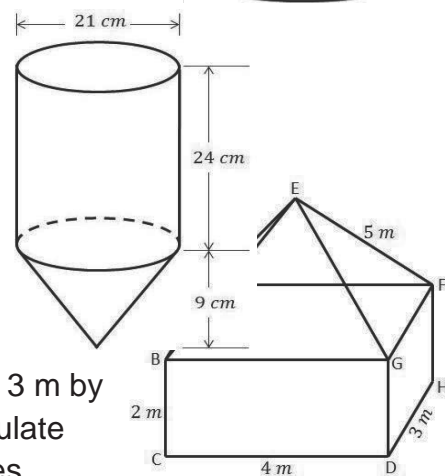

3. The diagram at right shows a pyramid standing on a cuboid. The dimensions of the cuboid are 4 m by 3 m by 2 m and the slant edge of the pyramid is 5 m. Calculate the volume of the shape, correct to 2 decimal places.

SSS 3 Maths Term 1 Answer Key

Lesson Title: Algebraic processes
Practice Activity: PHM3-L001

1. $x = 7, y = 3$

2. $x = 3, y = -2$

3. $x = 4, y = -5$

4. $x = 5\frac{5}{9}, y = 3\frac{2}{3}$

5. $x = 3, y = 4$

6. $x = 2, y = -3$

Lesson Title: Algebraic processes
Practice Activity: PHM3-L002

a. $y = x + 3$

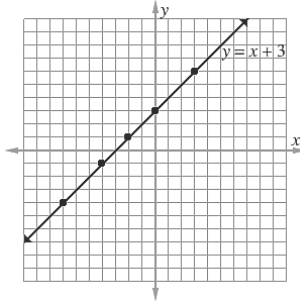

b. $y = 5x + 2$

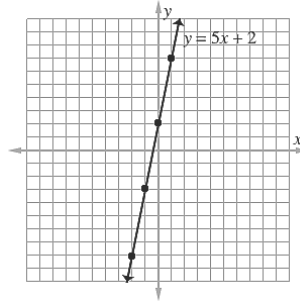

c. $y = -5$

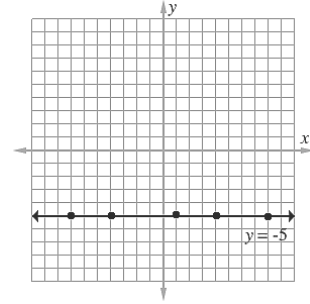

d. $y = -\frac{1}{3}x + \frac{2}{3}$

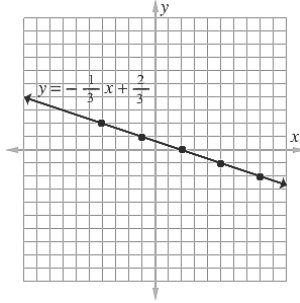

e. $y = \frac{3}{4}x + 4\frac{1}{4}$

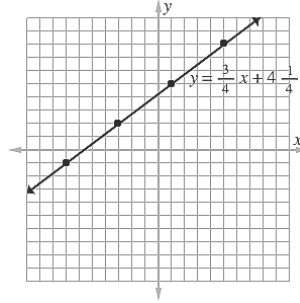

f. $y = -3x + \frac{1}{4}$

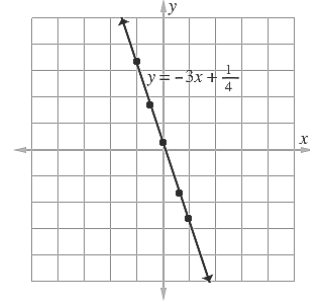

Lesson Title: Geometry
Practice Activity: PHM3-L003

1. 33 cm

2. 39°

3. a. $k = 120^\circ, p = 60^\circ$

b. $x = 70^\circ, y = 40^\circ, z = 110^\circ$

c. $d = 50^\circ \quad 3d = 150^\circ$

Lesson Title: Statistics

Lesson Number: PHM3-L004

1. a.

Class	Tally	Frequency f	x	fx
1 – 20	### II	7	10.5	73.5
21 – 40	### ### I	11	30.5	335.5
41 – 60	###	5	50.5	252.5
61 – 80	////	4	70.5	282
81 – 100	///	3	90.5	271.5
		$\Sigma f = 30$		$\Sigma fx = 1215$

b.

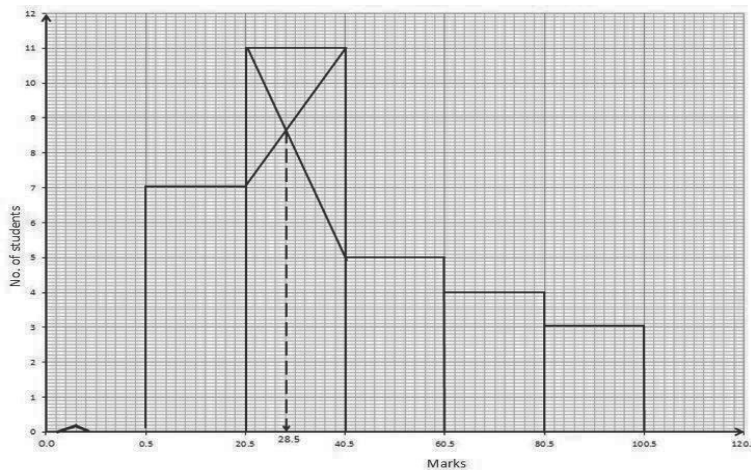

c. Mode = 28.5

d. Mean = 40.5

Lesson Title: Review of perimeters of shapes

Practice Activity: PHM3-L005

1. 62 cm

2. 24 cm

3. 28 cm

4. 16 cm

Lesson Title: Review of area of regular shapes

Practice Activity: PHM3-L006

1. 48 cm²

2. 10 cm

3. 120 cm²

4. a. 20 cm b. 24cm²

Lesson Title: Area of similar shapes

Practice Activity: PHM3-L007

1. 8 cm 2. 3 cm 3. 126 cm^2

Lesson Title: Area of compound shapes

Practice Activity: PHM3-L008

1. 22 cm^2 2. 48 cm^2 3. 124 cm^2 4. 76 cm^2

Lesson Title: Review of circles

Practice Activity: PHM3-L009

1. 66 cm
2. a. $d=24 \text{ m}$ and $C=75.43 \text{ m}$ b. $r=21 \text{ m}$ and $C=132 \text{ m}$
c. $r=98 \text{ mm}$ and $d=196 \text{ mm}$ d. $r=63 \text{ cm}$ and $C=396 \text{ cm}$
e. $d=70 \text{ mm}$ and $C=220 \text{ mm}$ f. $r=12.25 \text{ m}$ and $d=24.5 \text{ m}$
3. 44 rose trees

Lesson Title: Length of an arc

Practice Activity: PHM3-L010

1. 18° 2. 25 cm 3. 90° 4. 38.24 cm

Lesson Title: Perimeter of a sector

Practice Activity: PHM3-L011

1. 61 cm 2. a. 120 cm^2 b. 45.1 cm^2 3. 13.60 cm 4. 43 cm
5. a. 33 cm b. 47 cm

Lesson Title: Perimeter of a segment

Practice Activity: PHM3-L012

1. a. 10.4 cm b. 12.57 cm c. 22.97 cm 2. 42.9 cm
3. a. 106° b. 17.25 cm
4. 4.10 cm

Lesson Title: Area of a circle

Practice Activity: PHM3-L013

1. 1,018 cm² 2. 14 cm 3. 7 cm 4. 113 cm²

Lesson Title: Area of a sector

Practice Activity: PHM3-L014

1. 173.2 cm² 2. 139 cm² 3. 44° 4. 30° 5. 11 cm 6. 8.54 cm

Lesson Title: Area of a segment
--

Practice Activity: PHM3-L015

1. 72.94 cm² 2. 267 cm² 3. 176.51cm²

Lesson Title: Area and perimeter of composite shapes

Practice Activity: PHM3-L016

1. 176.52 cm² 2. 3,348.57 cm² 3. 858 cm² 4. a. 80 cm² b. 102 cm²
5. 12 cm²

Lesson Title: Circle Theorem 1

Practice Activity: PHM3-L017

1. 17 cm 2. 10 cm 3. 0.5 cm 4. 31.0 cm

Lesson Title: Applications of Circle Theorem 1

Lesson Number: PHM3-L018

1. 11.40 cm 2. 12 cm 3. 14 cm 4. 13.9 cm

Lesson Title: Circle Theorem 2

Lesson Number: PHM3-L019

1. a. $k = 152^\circ$ b. $y = 74^\circ$ c. $t = 140^\circ, u = 70^\circ, v = 70^\circ$

Lesson Title: Applications of Circle Theorem 2

Lesson Number: PHM3-L020

a. $d = 106^\circ$, $e = 254^\circ$, $f = 127^\circ$ b. $a = 75^\circ$, $b = 210^\circ$, $c = 105^\circ$

c. $w = 98^\circ$, $x = 131^\circ$, $y = 49^\circ$, $z = 131^\circ$

Lesson Title: Circle Theorems 3 and 4

Lesson Number: PHM3-L021

1. a. $y = 80^\circ$, $x = 50^\circ$ b. $x = 30^\circ$ c. $a = 42^\circ$ 2. 53°

Lesson Title: Applications of Circle Theorems 3 and 4

Lesson Number: PHM3-L022

1. a. $c = 42^\circ$ $d = 42^\circ$ $e = 48^\circ$ b. $f = 59^\circ$ $g = 31^\circ$ $h = 31^\circ$

c. $q = 83^\circ$ $r = 67^\circ$ $s = 67^\circ$ $t = 16^\circ$ $u = 55^\circ$ $v = 42^\circ$

Lesson Title: Circle Theorem 5

Lesson Number: PHM3-L023

1. a. $k=114^\circ$ $t=101^\circ$ b. $x=134^\circ$ $y=92^\circ$ $z=268^\circ$

c. $x=36^\circ$ $3x=108^\circ$ $2x=72^\circ$ $y=20^\circ$ $5y=100^\circ$ $4y=80^\circ$

Lesson Title: Applications of Circle Theorem 5

Lesson Number: PHM3-L024

1. a. $t=103^\circ$ $p=60^\circ$ $2p=120^\circ$

b. $r=102^\circ$ $p=156^\circ$

c. $f=111^\circ$ $g=95^\circ$

Lesson Title: Circle Theorems 6 and 7
Lesson Number: PHM3-L025

1. PA=12cm PB=12cm
2. a. $a=90^\circ$ $b=23^\circ$ $c=67^\circ$
2. b. $a=21^\circ$ $b=21^\circ$ $c=69^\circ$

Lesson Title: Applications of Circle Theorems 6 and 7
Lesson Number: PHM3-L026

1. $\angle APB = 40^\circ$ $\angle ABP = 70^\circ$
2. a. $a=40^\circ$ $b=90^\circ$ $c=50^\circ$ b. $y=48^\circ$

Lesson Title: Circle Theorem 8 – Alternate segment theorem
Lesson Number: PHM3-L027

1. $\angle QSR=37^\circ$ 2. $\angle PQT=54^\circ$ 3. $\angle DBC=53^\circ$ 4. $\angle SQR=52^\circ$ 5. $\angle TQR=110^\circ$

Lesson Title: Apply the alternate segment theorem
Lesson Number: PHM3-L028

1. $\angle MTN = 46^\circ$ 2. $\angle PRT = 64^\circ$ 3. $\angle SQT = 83^\circ$ 4. $\angle PQO = 35^\circ$

Lesson Title: Solving problems on circles
Lesson Number: PHM3-L029

1. $\angle PST=38^\circ$ 2. $\angle PST=54^\circ$ 3. $\angle UXY=80^\circ$ 4. $\angle VXU=55^\circ$

Lesson Title: Surface area of a cube
Lesson Number: PHM3-L030

1. 434 cm^2 2. 486 cm^2 3. 4 cm 4. 13 cm 5. $1,094 \text{ cm}^2$ 6. 12 cm

Lesson Title: Volume of a cube

Lesson Number: PHM3-L031

1. 5 cm 2. 343 cm^3 3. 8 cm 4. 729 cm^3 5. 8 6. 216

Lesson Title: Surface area of a cuboid

Lesson Number: PHM3-L032

1. 375 cm^2 2. 6 cm 3. 432 cm^2 4. a. 184 cm^2 b. 276 cm^2 5. 4cm 6. 15 cm

Lesson Title: Volume of a cuboid

Lesson Number: PHM3-L033

1. a. 160 cm^3 b. 280 cm^3 2. $120,000 \text{ cm}^3$ 3. 672 litres 4. 152 litres 5. 158 m^3
6. 112 m^3

Lesson Title: Nets of prisms

Lesson Number: PHM3-L034

1. i.

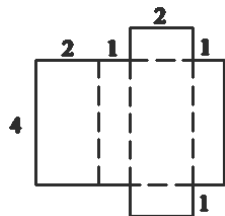

ii.

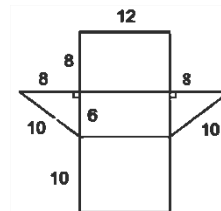

2. i.

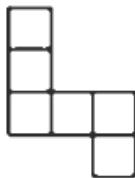

ii.

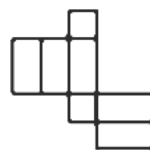

3.

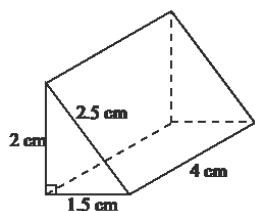

Lesson Title: Surface area of a triangular prism

Lesson Number: PHM3-L035

1. a. 671 cm^2 b. 720 cm^2 c. 771 cm^2

Lesson Title: Volume of a triangular prism

Lesson Number: PHM3-L036

1. a. 1680 cm^3 b. 660 cm^3 c. 606 cm^3

Lesson Title: Surface area of a cylinder

Lesson Number: PHM3-L037

1. 748 cm^2 2. 9 cm 3. a. 75 cm^2 132 cm^2 b. 377 cm^2 534 cm^2
c. 302 cm^2 402 cm^2 d. 113 cm^2 170 cm^2 4. $42\pi \text{ cm}^2$ 5. 289.14 cm^2

Lesson Title: Volume of a cylinder

Lesson Number: PHM3-L038

1. $3,560 \text{ cm}^3$ 2. 7.2 cm 3. 275 cm^3 4. 9 cm 5. 28.8 cm 6. 64

Lesson Title: Surface area of a cone

Lesson Number: PHM3-L039

1. a. 90.2 cm^2 b. 128.7 cm^2 2. 66 cm^2 51^0 3.154 cm^2
4. 14 cm 5. 10 cm

Lesson Title: Volume of a cone

Lesson Number: PHM3-L040

1. 99.2 cm^3 2. a. 4.7 cm b. 11cm c. 23° d. 250 cm^3
3. 15 cm 4. 21 cm 5. 148.5 cm^3

Lesson Title: Surface area of a rectangular pyramid

Lesson Number: PHM3-L041

1. a. 8.6 cm b. 10.3 cm c. 215.7 cm^3
2. a. 7.1 cm b. 55° c. 270 cm^3

Lesson Title: Volume of a rectangular pyramid

Lesson Number: PHM3-L042

1. 4 cm 2. a. 24.3 cm b. 32.0 c. $1,437.1 \text{ cm}^2$

Lesson Title: Surface area of a triangular pyramid

Lesson Number: PHM3-L043

1. a. 6.9 cm b. 13.3 cm c. 309.8 cm^2
2. a. 5.9 cm b. 235 cm^2
3. 394 cm^2

Lesson Title: Volume of a triangular pyramid

Lesson Number: PHM3-L044

1. a. 6.93 cm b. 13.3 cm c. 365 cm^3
2. a. 18.8 cm to 1 d.p. b. 752 cm^3
3. 365 cm^3

Lesson Title: Surface area of a sphere

Lesson Number: PHM3-L045

1. a. $1,386 \text{ cm}^2$ b. $2,828.57 \text{ cm}^2$ c. 124.74 cm^2
2. a. 8.4 cm b. 5.95 cm 3. $50,688 \text{ cm}^2$

Lesson Title: Volume of a sphere

Lesson Number: PHM3-L046

1. 4.33 cm 2. 4.92 cm 3. a. 180 cm^3 b. 310 cm^3 c. $1,000 \text{ cm}^3$
4. a. 12 cm b. 7 cm

Lesson Title: Surface area of composite solids

Lesson Number: PHM3-L047

1. $1,188 \text{ cm}^2$ 2. a. i 5.32 cm ii. 58.5 cm^2 iii. 141 cm^2 b. $\text{Le}99,750.00$
3. 884.84

Lesson Title: Volume of composite solids

Lesson Number: PHM3-L048

1. $2,567 \text{ cm}^3$
2. $9,353 \text{ cm}^3$
3. 41.32 m^3

Appendix I: Protractor

You can use a protractor to measure angles. If you do not have a protractor, you can make one with paper. Trace this protractor with a pen onto another piece of paper. Then, cut out the semi-circle using scissors.

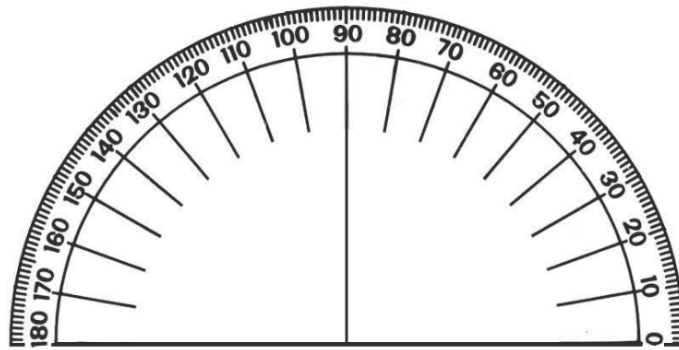

GOVERNMENT OF SIERRA LEONE

FUNDED BY



IN PARTNERSHIP WITH



STRICTLY NOT FOR SALE