

## WOODLESS CONSTRUCTION 3: CHANGE AND ADAPTION TO LOCAL NEEDS

**Woodless construction A south south  
technology transfer by Development Workshop  
over 30 years to address the environmental  
and construction issues of the West African  
Sahel region**

"Woodless Construction" is the name that has been given in the Sahel to the construction of buildings, in which all the structural elements, including the vault and dome roofs, are made of sun dried mud bricks.

Woodless Construction was developed to provide a viable, affordable and accessible alternative to a dual problem: how to alleviate pressure on the threatened natural resources of the Sahel and at the same time to make building by the population easier (see *Woodless Construction - 1: An overview* in this series of case studies).

The bricks for both walls and roofs are formed in rectangular moulds, smoothed by hand and left to dry in the sun for a few days - a method very widely known in the region. During construction, the dried bricks are laid in mud mortar. The vault and dome roofs are built using techniques which originated in Iran and Egypt. The most important characteristic of these roofs is that they are built without any supporting shuttering. Thus the entire structure - walls, lintels, and roofs - is built with locally available earth. Bringing an ancient building technique into a new region facing the same problems is not simple. In order for the process of training and dissemination to be effective, the way Woodless Construction techniques are both taught and are used in the Sahel have been the object of an ongoing process of evolution and adaptation to local conditions and training needs. This process of adaptation has

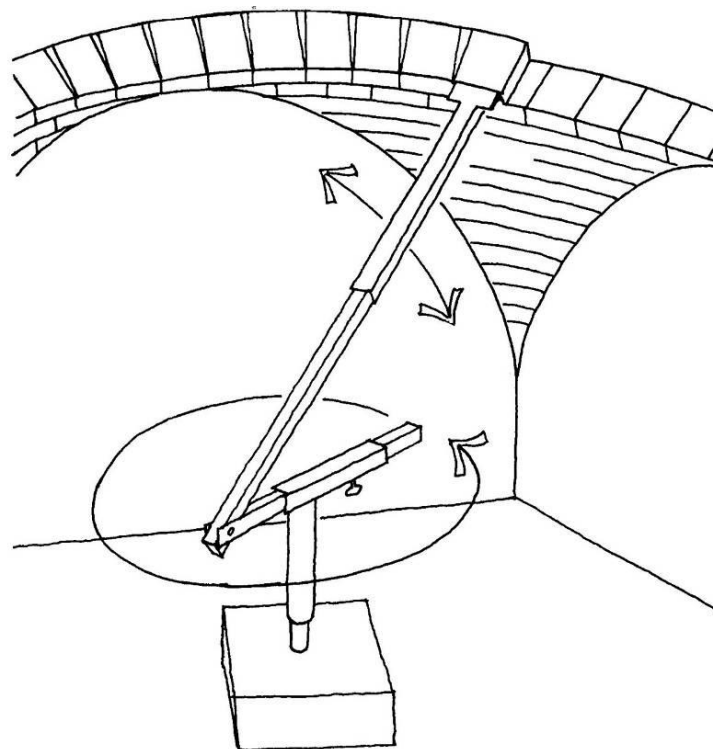

Figure 1: The mobile rotating guide precisely fixes the angle and position of every brick in the dome.

drawn upon Development Workshop's earlier experience of building with vaults and domes in Egypt and Iran countries which many centuries ago, facing similar conditions, developed their own techniques of dome and vault construction using mud bricks. In practical terms, adaptation of the traditional vault and dome techniques to the Sahelian context has focused on two main aspects:

- making the techniques easier to learn and use - often for illiterate and sometimes non-numerate builders - and thus safer;
- making the techniques respond to local needs and expectations - which includes keeping costs low and providing the shapes and appearance that the public want.

Adaptation has reflected both observations of local building techniques in the Sahel and discussion with the builders of each locality. The evolution of building techniques and forms is inspired by local practice, by local building techniques and styles, and by existing local solutions to problems and needs. Finding a solution to today's needs is thus a question of mixing viable existing local ideas such as the use of local wall renders with the new woodless construction techniques.

### Making woodless construction quicker to learn

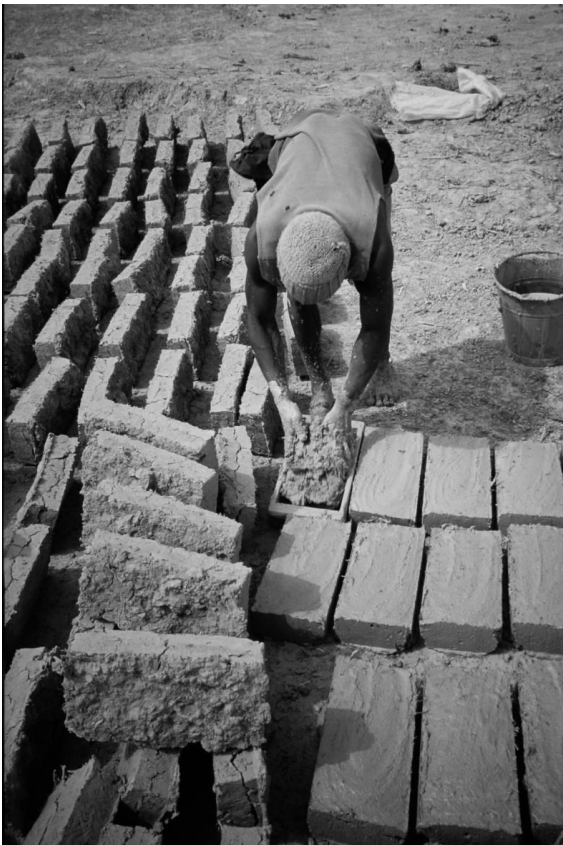

Figure 3: CSB uses local hand made local adobe bricks - no presses and no cement.



Figure 2: A mobile rotating guide at work.

The most important aspect of change in the way woodless construction has been introduced has been the development of a clearly structured training process managed by trained trainers. In both Egypt and Iran, traditionally builders learnt through an apprenticeship system with the guidance of a master mason. Gradually an apprentice would be allowed to do more and more complex structures. This could take many years. In West Africa, with the pressing need to slow down the excessive cutting of trees, there has not been the time to slowly develop the skills of new builders in an apprenticeship process. DW therefore developed a faster training approach using a detailed curriculum and specially designed training structures, a process which works efficiently. The training module for starter builders lasts three weeks and enables a novice builder to reach the point where he can build his own woodless house – and in the second part of the training, each trainee does indeed build his own home using the woodless construction techniques. For more detail on the organisation and content of training cycles, (see *Woodless Construction - 2: The training of trainers and builders*).

## Ongoing technical changes

### Using local brick sizes and laying methods

First introduced to Niger in 1980, during the next decade brick dimensions and bonding patterns for woodless construction used quite complex bond layouts with bricks laid as headers and stretchers - an often complex bonding pattern that acted as a brake on the assimilation of the techniques. To simplify building, and following common local practice, brick laying was then changed to "headers only" for the majority of small buildings, and adopted two main wall brick sizes – one measuring 38 x 24 cm, the other, 40 x 19 cm, both used in walls that are about 40cm thick (enough for a small domed or vaulted structure). These dimensions gave good results and remain popular today. A further step was to eliminate the need for cutting bricks to fit given metric measurements, which could result in poor bonding along a wall. Woodless Construction therefore adopted using the brick itself as the unit of measurement. This enables the laying out of the buildings to be based firstly on approximate metric dimensions and then laid out precisely on site in terms of an exact number of bricks and joints, an approach that takes account of local variations in brick sizes. Indeed, where the size of the local wall brick is adequate, today the programme accepts that local brick sizes can be used, provided a good brick bonding can be achieved.

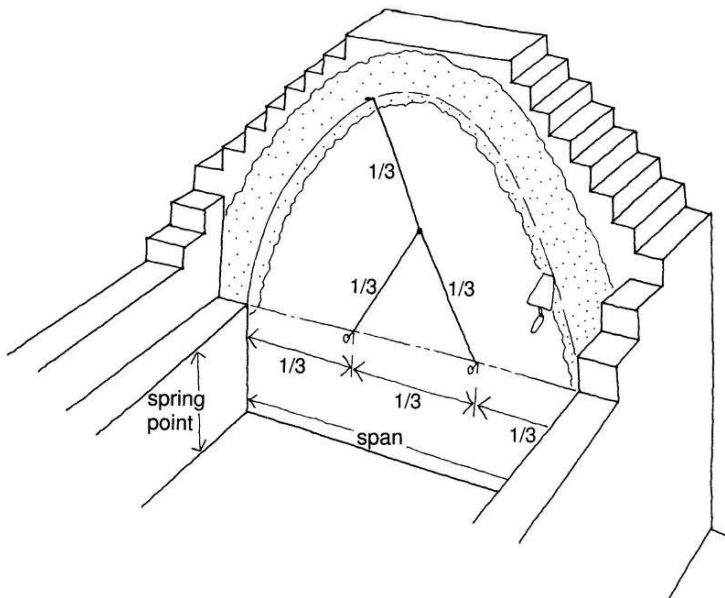

Figure 4: Vaults are drawn based on 1/3 of the span units.

achieved by folding into three a length of wire equal to the span. Based on this 'one third of the span' length, three equal length wires are joined at a common point. Two nails are placed at *spring point level* into the end walls of vaulted rooms at one and two third intervals, to which the end of two of the wires is attached. The builder can then quickly and accurately draw the curve of the vault. The vault shape is not only close to the *catenary* pure compression shape (the pure tension form of an inverted suspended chain) of the Nubian vaults, but in addition this slightly new shape has a more accentuated curve that compensates for the loading over the sides of vault produced by infilling the valleys in the roof.

### Keeping the vault alignment right

Nubian vaults are usually built out from one end wall, against which they lean. To help the Sahel builders keep a straight alignment, an early innovation has been the practice of

*The brick saw:* using the brick as a unit of measurement does however create potential conflict with inserting ready made joinery. One answer has been, when necessary, to build the width of openings a little smaller than required, and then to use a wire "mud brick saw" to trim the opening to the desired size. This avoids making unsafe adjustments to the bonding pattern in the wall.

### Drawing the vault

Nubian vaults in Upper Egypt were traditionally drawn by eye or in some cases with a template. Sahelian builders found accurate drawing of the vault by eye difficult to learn and the use of a template unwieldy and impractical since it was difficult to move from one location to another. For the Sahel builders a method has been developed that is based on using wires and on the subdivision of any vault span into three equal lengths, which is



Figure 5: Guiding strings help builders maintain the alignment of the vaults.



starting a vault simultaneously from both ends of the room, with a vault leaning against the 'gable end wall' at both ends. This allows guiding strings to be stretched from one end wall to the other just above the curve of the vault bricks that are to be laid. The builder checks that the progressive courses of the vault built out from the end wall follow the alignment of the strings. At each stage, the builder is also encouraged to place a string across the face of the vault which helps check the regular profile of the bricks that are being laid.

### The lower part of the vault

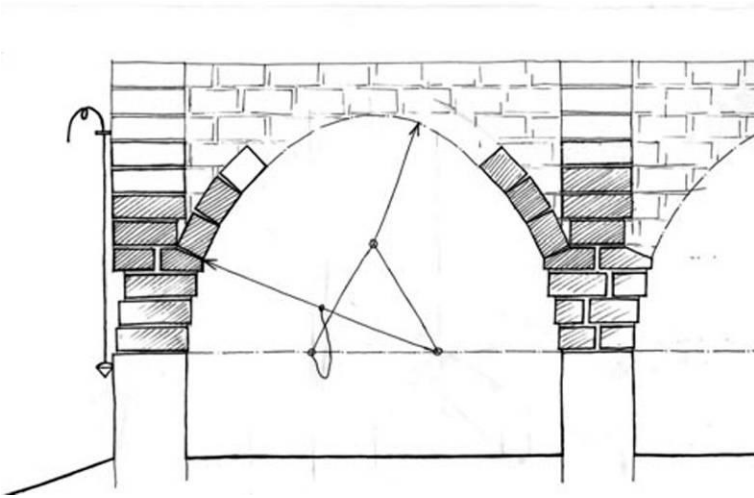

Figure 6: Vaults are built on corbelled masonry that is quicker and structurally safer.

Despite the strings, many builders found it difficult to keep the right curve in the lower part of the vault, which sometimes tended to bulge during construction, potentially leading to a weaker vault form. To overcome this, in the mid 1990s Development Workshop changed the vault building system, so that the builder now builds up the supporting wall on which the vault is built, with large bricks which are progressively stepped out to the interior of the vaulted room. The steps follow the curve of the vault. Actual vault bricks start to be laid about one third of the way up the height of the vault. Controlling the alignment of the stepped out bricks is both easy and fast, and builders prefer this new technique. This makes both for safer and quicker construction.

### Introducing eccentric roofs

With the same aim of reducing the spring point level and thus outward force on outside supporting walls, whilst gaining height on the opposite "interior" wall, "eccentricity" has been introduced as an option where the counter-thrust of an adjacent roof permits. The resulting rooms have more vertical wall against which furniture can be placed, and creating openings between adjacent rooms is easier. Eccentric or off-centred vaults and domes can only be built where two roof structures provide an opposing thrust.

### Reshaping the Egyptian dome

The hemispheric domes achieved by using a wire or string attached to a central pole produce a shape with considerable outward thrust in the lower part of the structure. Adjusting the dome to a steeper shape helps reduce this thrust. This has been achieved by introducing a factor of displacement at the rotating base of the radial arm that is used for positioning each brick in the dome. Displacement is usually by one third of the dome's radius. This gives a steeper curve to the profile of the dome, reduces outward thrust, and enables the dome to have a spring point lower down than that of a hemispherical dome whilst still achieving the same room height. The result is stronger and requires less wall structure, and the echo of hemispherical domes is also reduced. An adjustable metal guide is given to the masons on completion of their training.

### Responding to local needs and expectations

Whilst technical changes and new teaching ideas help the builders master woodless construction techniques quickly and help them learn to be flexible with their potential, changes to the form or appearance of the buildings makes assimilation by the population easier. These changes have implied that whilst the techniques remain essentially the same, their application can and should change to suit local needs. Builders are encouraged to decorate the inside and outside of their homes and one can often tell who has built a house by the way the outside has been finished.

### Flat roofs on vaults and domes

When introduced to Mali, woodless construction aroused strong local interest in the face of increasing difficulty in finding organic materials or the money to pay for non-local alternatives. Many people nevertheless wanted flat roofs, where they could sit and sleep outside during the hot season. As a result in subsequent training, the construction of flat roof terraces with vaults and domes was demonstrated, using secondary vaults and domes to bridge over the "valleys" between the main roof vaults or domes. The much smaller valleys in the roof that remain are filled in with earth. Combined with the use of eccentric domes and vaults these can further reduce the need for in fill in the roof, an otherwise expensive item.

### Reduced wall thickness

Woodless construction is mainly about changing the way that people build roofs, but how much material goes into walls is also a concern. In northern Niger, the traditional branch and straw shelter - the *tatagham* shelter built and used by women in nomad settlements - was also becoming hard to build because of difficulty in obtaining materials. A 200 mm thin walled domed structure was proposed as a replacement. Similar reductions in wall thickness for rectangular structures has also been introduced using alcoves, which - without reducing the strength of the wall - reduce the number of bricks needed and provide useful space.

### Replacing existing timber roofs with vaults and domes

In many parts of the Sahel, existing earth buildings already have thick masonry walls. As well as training for constructing new buildings with woodless construction, the Woodless Construction Programme has also demonstrated the potential for re-roofing existing wood roofed buildings with vaults and domes, provided of course that the walls are sufficiently strong. One particularly successful example of this was re-building the roof of an existing mosque, the wooden roof of which had rotted; this proved a highly popular and "visible" example to the local population. Technical changes are making Woodless Construction building easier and more attractive to clients. But just as important is the impact that these changes are having on how local masons and clients are taking decisions into their own hands: laying out bricks to measure the size of a new building on the ground, and then "re-arranging" rooms to suit the client's wishes; or trying out different vault positions by drawing full size on the wall. All increase opportunities for masons to find viable solutions to local clients' needs unaided.

### ***The promotion of Woodless Construction in Burkina Faso, Mali and Niger won the World Habitat Award in 1998***

### Selected references

*Woodless Construction 1: An Overview* J. Norton

*Woodless Construction 2: The Training of Trainers and Builders* J. Norton

[\*Building with Earth\*](#), 2<sup>nd</sup> Ed., J. Norton, Practical Action Publishing, 1997 (Order online at Practical Action Publishing)

*Woodless Construction – Unstabilised earth brick vault and dome roofing without formwork*. J. Norton, Lund University Centre for Habitat Studies, Vol 9,N°2, 1997 (Download at [www.dwf.org](http://www.dwf.org))

[\*Mud as a Mortar\*](#), Practical Action, Technical Brief

[\*The Construction of the Timberless House Model\*](#), Practical Action Sudan, Technical Brief

[\*Mud Plasters and Renders\*](#), Practical Action Sudan, Technical Brief

This technical brief was originally prepared for **basin**, Building Advisory Service and Information Network and updated by John Norton of Development Workshop in March 2012.

For more information on woodless construction, contact:



John Norton  
Development Workshop  
B.P. 13, F - 82 110 Lauzerte. France  
Tel: (+ 33) 63 95 82 34  
Fax: (+ 33) 63 95 82 42  
E-mail: [dwf@dwf.org](mailto:dwf@dwf.org)  
Website: <http://www.dwf.org>

Development Workshop works with some of the poorest communities in the world, developing local capacities to improve lives and livelihoods. For over 30 years Development Workshop has provided training and technical assistance to enable local people to deal with environmental challenges and natural disasters in more than 30 countries.

Practical Action  
The Schumacher Centre  
Bourton-on-Dunsmore  
Rugby, Warwickshire, CV23 9QZ  
United Kingdom  
Tel: +44 (0)1926 634400  
Fax: +44 (0)1926 634401  
E-mail: [inforserv@practicalaction.org.uk](mailto:inforserv@practicalaction.org.uk)  
Website: <http://practicalaction.org/practicalanswers/>

Practical Action is a development charity with a difference. Practical Action knows the simplest ideas can have the most profound, life-changing effect on poor people across the world. For over 40 years, we have been working closely with some of the world's poorest people - using simple technology to fight poverty and transform their lives for the better. Practical Action currently works in 15 countries in Africa, South Asia and Latin America.

All photographs: Development Workshop

technical brief