



DEPARTMENT OF
EDUCATION

UPPER SECONDARY
SCHOOL CERTIFICATE
EXAMINATIONS

APPLIED SCIENCE

Tuesday

21 October 2013

Time allowed:

2 hours and 30 minutes

(11:00am – 1:30 pm)

NO EXTRA TIME

(NO OTHER TIME)

Candidates are advised to fully
utilize the allocated time

INSTRUCTIONS TO CANDIDATES

To be read by the external invigilator to all candidates

1. The **subject code** for **Applied Science** is **9**.
2. There are **10** printed pages in the question booklet and **8 printed** pages in the answer booklet. There are two parts in this paper. Answer all questions.

Part A : Multiple Choice Questions - 30 marks

This section will be electronically marked.

Electronic Answer Sheets will be distributed by your external invigilator. All answers to the Multiple Choice Part **MUST** be answered on this Answer Sheet.

Carefully following the instructions, fill in your Candidate Information and Subject Information.

Part B: Short Answer Questions -70 marks

Write down your name, your school name and your 10-digit candidate number on the Part B Answer Sheet provided.

3. You are required to write the correct answer in the space provided.
4. Answers written on the question paper will not be marked. Write answers neatly in spaces as allocated on the answer sheet. Answer **ALL** questions.
5. Answer all questions on the answer sheet. Answers on any other paper including rough work paper and the question paper **will not be marked**
6. **ALL** working must be shown step by step to get full marks. Students may lose marks for writing down final answers only.
7. Enough spaces have been allocated for answers to every question. Questions must be answered in spaces as allocated. Answers all over the answer booklet may not be marked.
8. Correctional Fluid is not allowed on the answer sheet. Where you have made an error, cross out all the working and start on a new line.

**PENALTY FOR CHEATING OR ASSISTING TO CHEAT IN NATIONAL
EXAMINATIONS IS NON-CERTIFICATION.**

AS

**DO NOT TURN OVER THE PAGE
AND DO NOT WRITE
UNTIL YOU ARE TOLD TO START.**

PART A: MULTIPLE CHOICE**(QUESTIONS 1 to 30)****30 MARKS**

Answer each question by shading in with HB pencil, the circle directly under the correct alternative A, B, C or D.

If you make a mistake, rub it out completely using an eraser rubber and shade the correct answer on the ELECTRONIC ANSWER SHEET.

QUESTION 1

The oldest form of food preservation techniques from the list is

- A. heating. B. freezing. C. fermentation. D. sun drying.

QUESTION 2

After cooking in a traditional clay pot the food will still be warm after removal from the fireplace. This is due to

- A. low heat transfer. B. medium heat transfer.
C. very fast heat transfer. D. extremely fast heat transfer.

QUESTION 3

Biodiesel is an alternative fuel source. The two basic ingredients used in producing biodiesel are

- A. oil + catalyst in basic solution. B. oil + catalyst in acidic solution.
C. starch + catalyst in basic solution. D. starch + catalyst in acidic solution.

QUESTION 4

Which statement is true for carbon trade?

- A. Trading timber for money B. Sustainable logging operations
C. Non chemical pollution of forest D. Conserving forest resources

QUESTION 5

Reforestation is linked to

- A. clear felling and selective logging. B. selective planting of agricultural tree crops.
C. replacing logged trees with a young trees. D. using chainsaw in a logging operation.

QUESTION 6

Which two options listed below best relates to ecotourism?

- A. medicine and business B. conservation and business
C. carbon trade and business D. wood recycling and business

QUESTION 7

Air pollution is heavily contributed by non-renewable fossil fuels. As part of forest waste management, the forest residues after milling such as sawdust, which contain cellulose, can be used to make bioethanol to replace fossil fuels. The route of bio-ethanol production is

- A. wood hydrolysis → fermentation → distillation
- B. wood hydrolysis → nitrification → distillation
- C. wood hydrolysis → fumigation → distillation
- D. wood hydrolysis → purification → distillation

QUESTION 8

Choose from the list the most important reason as to why health safety is important in many places including household kitchen.

- A. Fear of attacks by relatives if accidents occur.
- B. Heavy compensation payment if accidents occur.
- C. Life and body parts are difficult to replace.
- D. Counseling is difficult for an injured person.

QUESTION 9

Which statement best describes the effect on chemical activities when temperature is lowered?

- A. Lower chemical activities
- B. Lower microbial activities
- C. Lower chemical and microbial activities
- D. No chemical or microbial activities

QUESTION 10

What is the best pH range due for fermentation?

- A. pH: 1 – 2
- B. pH: 3 – 5
- C. pH: 6 – 7
- D. pH: 8 – 9

QUESTION 11

Why is less heat applied to acidic foods like fruit juices in food processing?

- A. Less food poisoning bacteria survive in acidic environment.
- B. More food poisoning bacteria survive in acidic environment.
- C. There is no bacteria survival in acidic environment.
- D. Acidic foods are never heated due to the surrounding environment.

QUESTION 12

A food analysis experiment showed that the food analyzed had 60% moisture.

Which food is likely to fit into this category?

- A. Bread
- B. Raw sweet potato
- C. Canned peanut
- D. Potato chips

QUESTION 13

Which of the following alternatives is the best condition for extracting virgin coconut oil?

- A. Sun drying of coconut followed by solvent extraction.
- B. Smoke drying of coconut followed by oil extraction.
- C. Sun drying of coconut followed by oil expression.
- D. Smoke drying of coconut followed by oil expression.

QUESTION 14

Which option is the correct energy form of conversion associated with dynamos?

- A. Heat energy to light energy
- B. Electrical energy to mechanical energy
- C. Heat energy to electrical energy
- D. Mechanical energy to electrical energy

QUESTION 15

What is **not** true about Nuclear energy?

- A. Nuclear energy creates little or no green house gases
- B. Life span of current reactors is approximately 60 years
- C. Nuclear energy is classified as being renewable energy source.
- D. Spent fuels storage and disposal can become an environmental issue.

QUESTION 16

An electric urn has a heating element with resistance 1200Ω , operates from a 240 volts (AC) with current rating of 10A.

How much energy would have been expended by the element to heat up water in 35 minutes?

- A. 252 KJ
- B. 2.88 MJ
- C. 5.04 MJ
- D. 252 MJ

QUESTION 17

Who is the inventor that built a wireless communication system in 1895 capable of transmitting signal at long distances?

- A. John Fleming
- B. Nikola Telsa
- C. Guglielmo Marconi
- D. Michael Faraday

QUESTION 18

In diodes and rectification, what does the acronym LED stands for?

- A. Light Extraction Device
- B. Light Emitting Device
- C. Long Echo Detection
- D. Light Emitting Diode

QUESTION 19

The parking sensor system of a vehicle uses wave technology to detect obstacles for safe parking by means of Distance Measuring Algorithm and _____ Wave Propagation and Detection.

- A. Electromagnetic B. Acoustic C. Infrared D. Optical

QUESTION 20

What is the pH of distilled water?

- A. 3 B. 7 C. 8 D. 14

QUESTION 21

A beaker of water containing sodium chloride is an example of

- A. mineral water. B. compound. C. solution. D. mixtures.

QUESTION 22

The list below describes the condition of some water systems.

- (i). A spring water containing dissolved minerals such as calcium, magnesium, iron etc.
- (ii). Flood water carrying mud and debris including dissolved minerals after heavy rain.
- (iii). Drain water carrying oil discharge from a nearby workshop.
- (iv). Treated drinking water containing traces of chlorine.
- (v). Cyanide leakage into Fly River system from the mining activities in Ok Tedi.

Which of the above best describes an industrial pollution?

- A. (i) and (ii) B. (ii) and (iv) C. (iii) and (iv) D. (iii) and (v)

QUESTION 23

Positive pregnancy tests are based on the presence of _____ in the blood of the pregnant women.

- A. Follicle Stimulations Hormone (FSH) B. Human Chorionic Gonadotropin (HCG)
C. Lutenizins Hormone (LH) D. Gonadotropin Releasing Hormone (GnRH)

QUESTION 24

Penicillin is a natural product and was the first commercially made antibiotic in the world.

What is the organic source of penicillin?

- A. Plant B. Fungi C. Bacteria D. Virus

PART B: SHORT ANSWERS**(QUESTIONS 31 to 40)****70 MARKS**

For each Question, work out the answers for each question and write the answer in the space provided on the ANSWER BOOKLET.

QUESTION 31

- i. State the two important reasons as to why smoking is used in food preservation. (2 marks)
- ii. Traditionally, fish is soaked in water before sun drying. Soaking the fish in salt water involves osmosis. Explain movement of salt and water in the process. (2 marks)
- iii. Explain the reason why food cooks faster in Aluminium pot than clay pot. (2 marks)
- iv. Complete the statement on 'Tapa Cloth' making.
Pressing the tree barks with wood _____ the surface area. (1 mark)

QUESTION 32

- i. Hydro power is the most common mode of power generation in Papua New Guinea. Relate the magnitude of potential head and water flow rate to amount of power generated. (2 marks)
- ii. An electric cooker is designed to operate at 2 kilowatts. Estimate the cost of running the cooker for two hours if PNG Power charges the power users K0.06 per kilowatt-hour. (2 marks)
- iii. In biogas production, fermentation of organic wastes yields several gases.
 - a. Name the cooking gas produced. (1 mark)
 - b. Name the useful byproduct after the gas production process ceases. (1 mark)
 - c. Name the main classes of microorganisms involved in the final stage of gas production. (1 mark)

QUESTION 33

- i. Name the reference chemical compound used in comparing effects of other green house gases to global warming. (1 mark)
- ii. Name the blanket layer in the atmosphere that once destroyed can be harmful to human life. (1 mark)
- iii. Explain in simple terms what carbon trade is? (2 marks)
- iv. What is a non-biodegradable material? (1 mark)
- v. Discuss why mangroves are important in conserving marine species and how they also protect land. (2 marks)

QUESTION 34

- i. What are organic foods? (1 mark)
- ii. Explain how microorganisms are killed by UV radiation. (2 marks)
- iii. Explain why Ultra High Temperature (UHT) products store longer than pasteurized products. (2 marks)
- iv. At room temperature, what state will fat and oil be in? (2 marks)

QUESTION 35

- i. The LED and incandescent lamp are similar in the sense that they both produce light. They however differ from each other in some ways.
State three ways by which they differ from each other. (3 marks)
- ii. Photos of an apple were taken simultaneously by two digital cameras. Camera A has a resolution of 5 megapixels while camera B has resolution to 10 megapixels.
Which camera will produce the best photo and why? (2 marks)
- iii. State two functions of the printed circuit board (PCB). (2 marks)

QUESTION 36

- i. Name the parts **a**, **b** and **c** of the transistor below and state whether it is a NPN-transistor or a PNP-transistor. (4 marks)

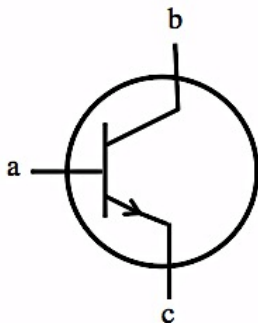

- ii. Calculate the capacitance of a parallel plate capacitor with plate area 0.0025m^2 , distance of separation between the plates being 0.001m .
Dielectric constant is taken to be $8.93 \times 10^{-9} \text{ F/m}$. (3 marks)

QUESTION 37

A typical water treatment procedure is shown in the diagram below. Generally there are seven treatment stations **i**, **ii**, **iii**, **iv**, **v**, **vi** and **vii**. (7 marks)

Study the diagram carefully and assign the appropriate heading from the list below to the corresponding station number. Appropriate headings suggested for each of the seven stations are NOT IN CORRECT ORDER.

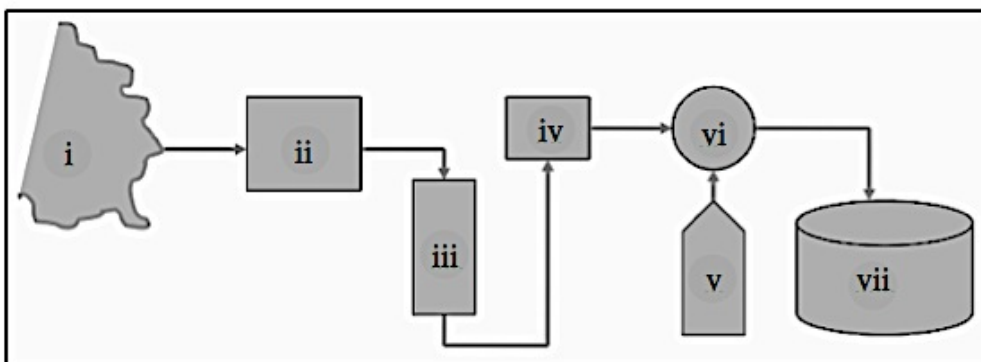

HEADINGS:

Reservoir, Chlorination, Storage tank, Coagulation and sedimentation, Mixing chamber, Sand filtration, Aeration

QUESTION 38

AIDS is short for 'Acquired Immune Deficiency Syndrome'. It characterised by the suppression of the immune system, which often leads to development of rare infectious diseases.

- What is the general name of the virus that causes AIDS? (1 mark)
- List three ways in which the spread of HIV can be effectively prevented in PNG. (3 marks)
- Name three common infectious diseases that are prevalent in PNG. (3 marks)

QUESTION 39

In an extraction experiment the bark of a medicinal plant was extracted by boiling. After cooling to room temperature, diethyl ether was added. Addition of diethyl ether resolved (separated) the mixture into two separate layers 'R' and 'S' as shown in the diagram below.

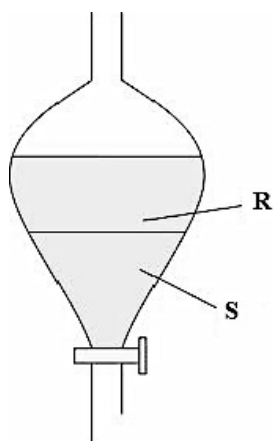

- Which layer is the water layer and which is the diethyl ether? (2 marks)
- In which layer will the oil will be? (1 mark)
- Briefly discuss the difference between oil and water and how the diethyl ether influences the separation into two layers. (2 marks)
- Plant oils are also called essential oils and have wider applications (uses).
List two applications of essential plant oils. (2 marks)

QUESTION 40

Limestone, marble, and seashells are some of the main minerals used in the production of lime.

- Write the chemical symbol of the major composition of these materials. (1 mark)
- Write the chemical name of lime. (1 mark)
- Write the overall chemical reaction (equation) for the production of lime. (2 marks)
- State one industrial application (use) of lime. (1 mark)
- What mass of solid lime would be produced if 2500g of pure calcium carbonate, $\text{CaCO}_3(\text{s})$, was burnt?
[Note: Formula Mass of Ca = 40; C = 12; O = 16] (2 marks)

END OF EXAMINATION

APPLIED SCIENCE

PART B – ANSWER BOOKLET

Write your name, province and school codes and your candidate number correctly and clearly in the space provided below.

| Year | | Province | | School | | | Candidate No | | |
|------|---|----------|--|--------|--|--|--------------|--|--|
| 1 | 3 | | | | | | | | |

Candidate Name: _____

School Name: _____

ANSWERS WRITTEN ON THE QUESTION PAPER OR ANY OTHER PAPER WILL NOT BE MARKED.

WRITE ANSWERS NEATLY IN THE SPACES PROVIDED IN THIS ANSWER BOOKLET

FOR MARKERS USE ONLY

| | Score | Markers' Initials | |
|--------------------|-----------|-------------------|----------|
| | | Marker 1 | Marker 2 |
| PART B | | | |
| QUESTION 31 | | | |
| QUESTION 32 | | | |
| QUESTION 33 | | | |
| QUESTION 34 | | | |
| QUESTION 35 | | | |
| QUESTION 36 | | | |
| QUESTION 37 | | | |
| QUESTION 38 | | | |
| QUESTION 39 | | | |
| QUESTION 40 | | | |
| FINAL TOTAL | 70 | | |

START YOUR WORK ON THE NEXT PAGE

| Question 31 | Marks per Qs. | Marker 1 | Marker 2 |
|--------------------------|------------------------------|---------------------|---------------------|
| i. a. | | | |
| | 1 | | |
| b. | | | |
| | 1 | | |
| | | | |
| ii. | | | |
| | 2 | | |
| | | | |
| iii. | | | |
| | 2 | | |
| | | | |
| iv. | | | |
| | 1 | | |
| Total Marks => | 7 | | |

| Question 32 | Marks per Qs. | Marker 1 | Marker 2 |
|--------------------------|------------------------------|---------------------|---------------------|
| i. | | | |
| | 2 | | |
| | | | |
| ii. | | | |
| | 2 | | |
| | | | |
| iii. a. | | | |
| | 1 | | |
| b. | | | |
| | 1 | | |
| c. | | | |
| | 1 | | |
| Total Marks => | 7 | | |

| Question 33 | Marks per Qs. | Marker 1 | Marker 2 |
|--------------------------|----------------------|-----------------|-----------------|
| i. | 1 | | |
| | | | |
| ii. | 1 | | |
| | | | |
| iii. | | | |
| | | | |
| | 2 | | |
| | | | |
| iv. | 1 | | |
| | | | |
| v. | | | |
| | | | |
| | 2 | | |
| Total Marks => | | | 7 |

| Question 34 | Marks per Qs. | Marker 1 | Marker 2 |
|--------------------------|----------------------|-----------------|-----------------|
| i. | 1 | | |
| | | | |
| ii. | | | |
| | 2 | | |
| | | | |
| iii. | | | |
| | 2 | | |
| | | | |
| iv. | | | |
| | 2 | | |
| Total Marks => | | | 7 |

| Question 35 | Marks per Qs. | Marker 1 | Marker 2 |
|--------------------------|------------------------------|---------------------|---------------------|
| i. a. | 1 | | |
| b. | 1 | | |
| c. | 1 | | |
| | | | |
| ii. | | | |
| | 2 | | |
| | | | |
| iii. a. | 1 | | |
| b. | 1 | | |
| <i>Total Marks =></i> | | | 7 |

| Question 36 | Marks per Qs. | Marker 1 | Marker 2 |
|--------------------------|------------------------------|---------------------|---------------------|
| i. a. | 1 | | |
| b. | 1 | | |
| c. | 1 | | |
| d. | 1 | | |
| | | | |
| ii. | | | |
| | 3 | | |
| <i>Total Marks =></i> | | | 7 |

| Question 37 | Marks per Qs. | Marker 1 | Marker 2 |
|--------------------------|------------------------------|---------------------|---------------------|
| i. | 1 | | |
| ii. | 1 | | |
| iii. | 1 | | |
| iv. | 1 | | |
| v. | 1 | | |
| vi. | 1 | | |
| vii. | 1 | | |
| <i>Total Marks =></i> | 7 | | |

| Question 38 | Marks per Qs. | Marker 1 | Marker 2 |
|--------------------------|------------------------------|---------------------|---------------------|
| i. | 1 | | |
| | | | |
| ii. a. | 1 | | |
| b. | 1 | | |
| c. | 1 | | |
| | | | |
| iii. a. | 1 | | |
| b. | 1 | | |
| c. | 1 | | |
| <i>Total Marks =></i> | 7 | | |

| Question 39 | Marks per Qs. | Marker 1 | Marker 2 |
|--------------------------|------------------------------|---------------------|---------------------|
| i. a. | 1 | | |
| b. | 1 | | |
| | | | |
| ii. | 1 | | |
| | | | |
| iii. | | | |
| | 2 | | |
| | | | |
| iv. a. | 1 | | |
| b. | 1 | | |
| <i>Total Marks =></i> | | 7 | |

| Question 40 | Marks per Qs. | Marker 1 | Marker 2 |
|--------------------------|------------------------------|---------------------|---------------------|
| i. | 1 | | |
| | | | |
| ii. | 1 | | |
| | | | |
| iii. | 2 | | |
| | | | |
| iv. | 1 | | |
| | | | |
| v. | 2 | | |
| <i>Total Marks =></i> | | 7 | |

